

# IOT BASED ANTI THEFT DETECTION AND ALERTING SYSTEM USING RASPBERRY PI

U. Sirisha<sup>1</sup>

D. PoojaSri<sup>2</sup>, N. Gayathri<sup>3</sup>, K. Heshma<sup>4</sup>, G. Raja Sekhar<sup>5</sup>,

<sup>1</sup> Assistant professor, Department of Computer Science Engineering, Dhanekula Institute of Engineering Technology, Andhra Pradesh, India

<sup>2,3,4,5</sup> Student, Department of Computer Science Engineering, Dhanekula Institute of Engineering Technology, Andhra Pradesh, India

\*\*\*

**Abstract** - To secure and guard our house in our absence, we propose the IOT based Anti-theft detection and alert System using Raspberry Pi. This system monitors the entire floor for movement. One single step anywhere on the floor is tracked and user is alarmed through mail over IOT. In this system, secure flooring tile connected with IOT, when the system is to be turned on, then whoever comes inside the house it passes the information over IOT. Whenever the thief enters in the house, and steps on the floor immediately it is sensed by the sensor which passes on the signal to raspberry pi controller. The controller in turn processes it to be valid signal and then moves the camera to the area where movement was detected and then transmits it over the Internet for the home owner to check the image.

**Key Words:** IOT (Internet of Things), Raspberry Pi, PIZO Sensor, GMAIL, Pi Camera.

## 1. INTRODUCTION

Now-a-days, Security has become the most challenging task. Everyone wants safety but in present scenario, nothing is safe not even in their own houses. Home is a place where we keep our assets and our capital. But we can never be sure about the security of that asset behind us and the possibilities of intrusion are increasing day by day. We generally lock houses when going out of the house. But just locking the home is not enough, there must be a system which safety our home, belongings and income from theft is the necessary requirements for home security system and keep track of the activities and report to the owner accordingly and works according to the response of the owner.

### 1.1 Proposed System

#### Anti-Theft Detection And Alert System Using RPi :

Whenever the thief enters in the house, and steps on the floor immediately it is sensed by the sensor which

passes on the signal to raspberry pi controller. The controller in turn processes it to be valid signal and then moves the camera to the area where movement was detected and then transmits it over the Internet for the home owner to check the image.

## 2. SYSTEM BLOCK DIAGRAM

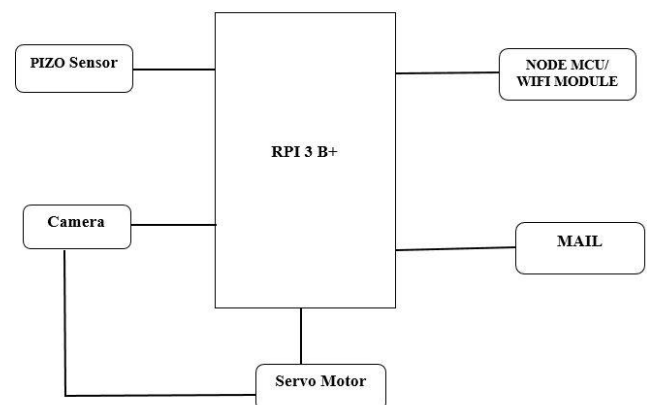

**Fig. 1** Block diagram of Raspberry-pi based anti-theft detection system

## 3. HARDWARE DESCRIPTION

### 1. Raspberry Pi Camera

Camera module is Pi camera interfacing to the raspberry pi module. Its resolution is 5-megapixel and still picture resolution 2592 x 1944, Max image transfer rate 1080p: 30fps, this Pi camera module is used for captures an image and send captured image to the Raspberry pi module.



Fig. 2 Pi Camera

## 2. Servo Motor

Attach the servo to a GPIO (we selected GPIO 17 here) of the Raspberry pi and control its rotation utilizing pulse-width modulation. The servo is powered by a 6V-battery pack. SG90 is a small servo motor with standard functionality and working. This servo motor rotates 180 degrees, 90 degrees in each direction. Controlling this motor is not so much difficult like it does not require any motor controller and can be controlled by any servo code or library, most suitable for beginners. The motor comes with 3 arms and hardware. Being a digital servo motor it receives and processes PWM signal.



Fig.3 Servo Motor

## 3. PIZO Sensor

A piezoelectric sensor, also known as a piezoelectric transducer, is a device that uses the piezoelectric effect to measure changes in pressure, acceleration, temperature, strain or force by converting these into an electrical charge. The prefix piezo is Greek for press or squeeze. The ability of piezoelectric material to convert mechanical stress into electrical charge is called a piezoelectric effect. Generated piezoelectricity is proportional to the pressure applied to solid piezoelectric crystal materials.

## 4. RASPBERRY PI 3 (MODEL B+)

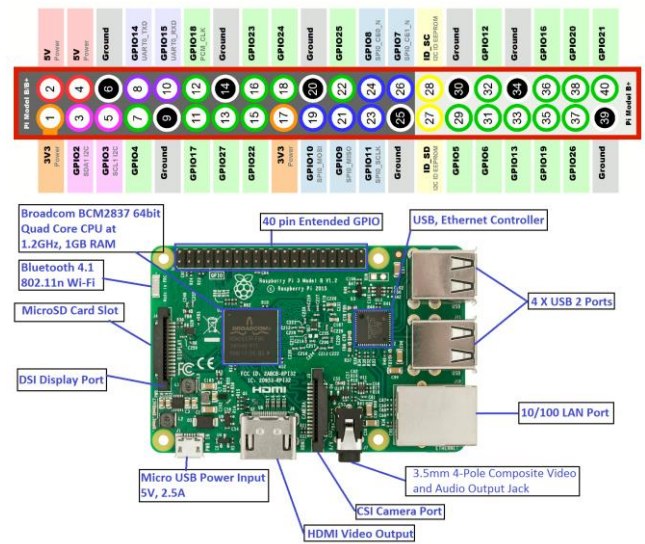

Fig. 3 Paspberry Pi 3B+

Raspberry pi is Broadcom BCM2837 64bit ARMv7 Quad Core Processor powered Single Board Computer running at 1.2GHz.

### In-built:

- BCM43143 WiFi on board
- Bluetooth Low Energy (BLE) on board
- Micro SD port for loading your operating system and storing data
- 1GB RAM
- 40pin extended GPIO
- 4 x USB 2 ports
- 4 pole Stereo output and Composite video port
- Upgraded switched Micro USB power source (now supports up to 2.4 Amps)
- CSI camera port for connecting the Raspberry Pi camera.

### 5. NODE MCU

NodeMCU is an open-source firmware and development kit that helps you to prototype or build IoT products. It includes firmware that runs on the ESP8266 Wi-Fi SoC from Espressif Systems, and hardware which is based on the ESP-12 module. The firmware uses the Lua scripting language. It is based on the eLua project and built on the Espressif Non-OS SDK for ESP8266.

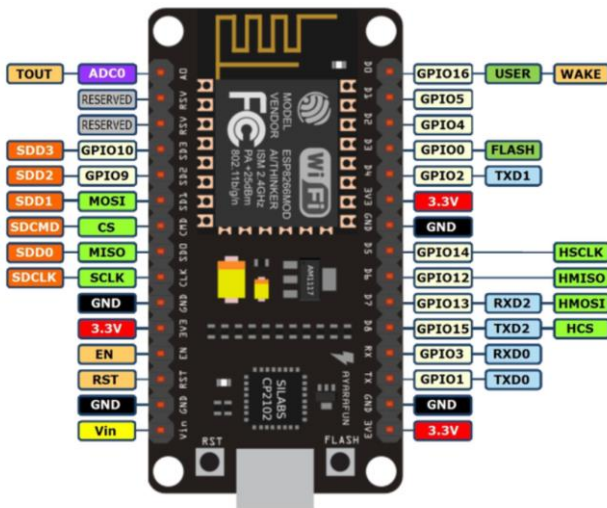

Fig. 4 NODEMCU

### 4. SOFTWARE DESCRIPTION

The software components are used for the project has been mentioned below:

#### 4.1 Raspbian OS:

Raspbian is an unofficial port of Debian Wheezy armhf with compilation settings adjusted to produce optimized "hard float" code that will run on the Raspberry Pi. This provides significantly faster performance for applications that make heavy use of floating point arithmetic operations. All other applications will also gain some performance through the use of advanced instructions of the ARMv6 CPU in Raspberry Pi.

Although Raspbian is primarily the efforts of Mike Thompson (mthompson) and Peter Green (plug wash), it has also benefited greatly from the enthusiastic support of Raspberry Pi community members who wish to get the maximum performance from their device.

#### 4.2 PYTHON:

Python is an easy to learn, powerful programming language. It has efficient high-level data structures and a simple but effective approach to object-oriented programming. Python's elegant syntax and dynamic typing, together with its interpreted nature, make it an ideal language for scripting and rapid application development in many areas on most platforms.

The Python interpreter and the extensive standard library are freely available in source or binary form for all major platforms from the Python Web site, <https://www.python.org/>, and may be freely distributed. The same site also contains distributions of and pointers to many free third party Python modules, programs and tools, and additional documentation.

The Python interpreter is easily extended with new functions and data types implemented in C or C++ (or other languages callable from C). Python is also suitable as an extension language for customizable applications.

#### 4.3 OPEN CV:

Open CV (Open Source Computer Vision Library) is an open source computer vision and machine learning software library. Open CV was built to provide a common infrastructure for computer vision applications and to accelerate the use of machine perception in the commercial products. Being a BSD-licensed product, Open CV makes it easy for businesses to utilize and modify the code. It is free for both commercial and non-commercial use.

### 5. ARCHITECTURAL FLOW OF SYSTEM

Following Figures shows the architectural flow of system installation process and working of the proposed system which will lead to prevention of Theft.

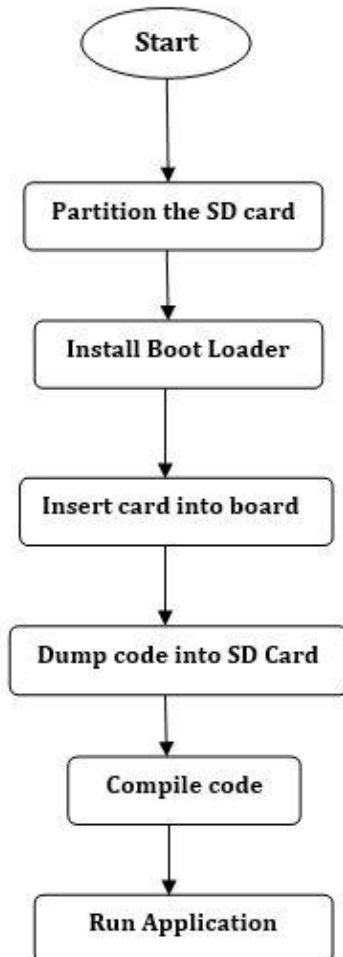

Fig. 5 Installation Process

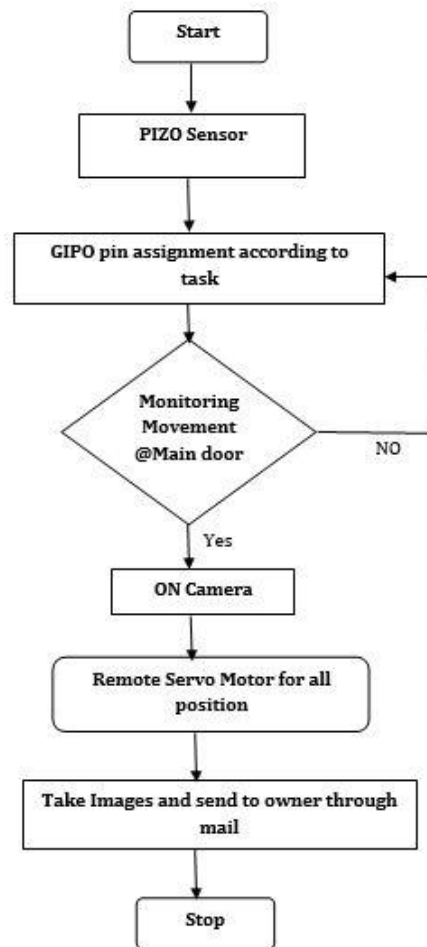

Fig. 6 Flow Chart

### 6. WORKING AND RESULT

In this project raspberry pi 3B+ (model) has been used as heart of system. This proposed system is an intelligent system and it eliminates the need of continuous by human resource. Thus, any human extra work is ruled out.

This system continuously checks the status of place by sensors that Is anyone entering in the shop or not. And sends the alert message to the owner with live images by rotating camera with different angles.

In this security system human bodies are detected by PIZO sensor.

The main aim of this project is to make an automated security system for Banks and jewelry shops.

The project consists of Raspberry Pi with sensor and camera. The whole system is placed in that place. If system detect someone in Bank/shop it sets the capture the live images and sent it on e-mail.

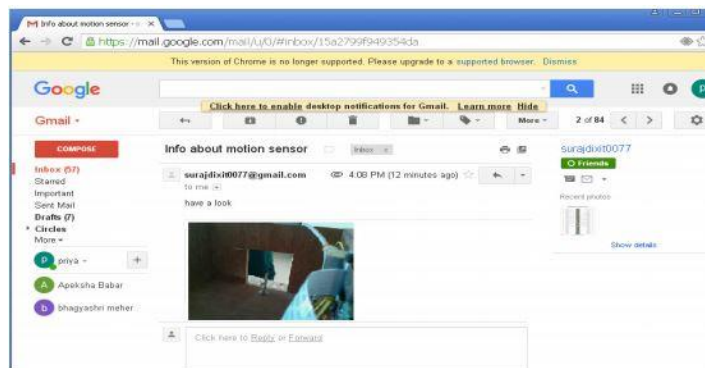

**Fig. 7** Image sent on mail

### 7. ADVANTAGES

1. The device was capable in distinguishing between human and animal intrusion using sensor for body temperature detection.
2. It was using an alarm system which uses to alert the owner by making sound.
3. It was convenient in use, relatively free from false alarms and does not require frequent user action to arm and disarm the system.

### 8. DIS-ADVANTAGES

1. The use of sensor for body temperature detection increases the cost of the project.
2. The sound was made by device will not be recognized by the owner, if he/she is not present there.

### 9. APPLICATIONS

- Jewelry Shops
- Army Surveillance
- Bank Locker Room
- Museum Security
- Home Security

### 10. CONCLUSIONS

The research work that will be carried out in this thesis would be mainly focused to design and develop efficient and convenient motion detection surveillance i.e. an Anti-Theft device to solve security problems which will help to reduce/stop theft. This system is suitable for small personal area surveillance. I.e. personal office cabin, bank locker room, parking entrance. Whenever the motion is detected through. The main Advantage of the project is Easy to implement, Low cost with High quality.

### REFERENCES

- [1] IOT based Raspberry Pi Home Security System with Email Alert, Circuit Digest.com, and Saddam.
- [2] Priya B. Patel, Viraj M. Choksi, Swapna Jadhav, M.B. Potdar, "Smart Motion Detection System using Raspberry Pi" International Journal of Applied Information Systems (IJ AIS) – ISSN: 2249-0868 Foundation of Computer Science FCS, New York, USA Volume 10 – No.5, February 2016.
- [3] D. Pavithra; Ranjith Balakrishnan, "IOT based monitoring and control system for home automation", IEEE Explore, Communication Technologies (GCCT), 2015 Global Conference on.

### BIOGRAPHIES



#### D. Pooja Sri

A UG Final Year student seeking his degree in Computer Science Engineering at Dhanekula institute of engineering and technology, Vijayawada, Andhra Pradesh.



#### N. Gayathri

A UG Final Year student seeking his degree in Computer Science Engineering at Dhanekula institute of engineering and technology, Vijayawada, Andhra Pradesh.



#### K. Heshma

A UG Final Year student seeking his degree in Computer Science Engineering at Dhanekula institute of engineering and technology, Vijayawada, Andhra Pradesh.



**G. Rajasekhar**

A UG Final Year student seeking his degree in Computer Science Engineering at Dhanekula institute of engineering and technology, Vijayawada, Andhra Pradesh.