

# AUTOMATED RAILWAY CROSSING SYSTEM USING IoT

Mrs P. Sunitha<sup>1\*</sup>, M. Eswar Krishna<sup>1</sup>, D. Deepika<sup>2</sup>, D. Divya<sup>3</sup>, K. Bhargav<sup>4</sup>

<sup>1\*</sup>Assistant Professor, Dept. of Computer science & Engineering, Dhanekula Institute of Engineering & Technology, Ganguru, AP.

<sup>1,2,3,4</sup>B.Tech Student, Dept. of Computer science & Engineering, Dhanekula Institute of Engineering & Technology, Ganguru, AP.

\*\*\*

**Abstract** - The railway crossing systems are operated manually by a gatekeeper. Over 50% of railway accidents occur due to operational errors in railway level crossings. But there is no perfect solution to this problem. In this project we proposed an automatic railway crossing system using internet of things technology. In this we will use ultrasonic sensors to track the train and these sensors are placed at a threshold distance which is calculated on the basis of train type and speed of the train. The arrival and departure of trains are detected by the ultrasonic sensors, when the sensors detects the train then the green traffic signal light turns to red and the level crossing gates are closed and the warning signal (buzzers) will be played until the train crosses the railway crossing and each time the train is detected by the ultrasonic sensor the status of train is updated in the cloud. The system is implemented by using Arduino microcontroller, servo motors and ultrasonic sensor and NodeMcu ESP8266. By implementing this system we will reduce the accidents held at level crossings at maximum extent Thus, the man power could be reduced.

**Key Words:** Arduino microcontroller, NodeMcu ESP8266, Servo Motors, Ultrasonic Sensors.

## 1. INTRODUCTION

The railway systems in India and other countries are the most commonly used mode of transportation and it is also one of the low cost modes of transportation. There are thousands of rails running on track every day. In railway systems it is impossible to stop some of the critical situations or emergencies that occur during the running of the train. Every year nearly 20,000 people lose their lives in railway crossing accidents. The system which is used today by the Indian railways at the railway crossings is not reliable and safe. The railway gates are manually operated by a gatekeeper when any communication mismatch occurs while sending the train status to the gatekeeper this will lead to accidents at railway crossing. The present solution is not the best and efficient way to handle railway gates and it is very error prone.

A railway crossing is an intersection of a road and a railway track. It requires human coordination to open and close the gates when the train arrives at the crossing station. Lack of this proper communication to the gatekeeper about train arrival will lead to accidents and

loss of human life, loss of property. In order to avoid the human mistakes which occur while operating the gates a new automatic railway crossing system is developed using IoT.

The second important problem in the manual railway crossing system is that vehicles have to wait more time at railway crossings even if the train leaves the crossing station. In manual systems the gatekeeper will close the railway gates when the train is at a distance of 10km from the station and open the railway gates after the train departed the station and it goes 10km away from the crossing station. When the train leaves the station there will be no chance of causing accidents and the vehicles can go now.

In order to avoid the number of accidents occurring at railway crossings and reduce the maximum time delay at railway crossing we proposed a solution which is used to automate the manual operations of the railway crossing system using IoT. Our System will provide a smart solution to the railway crossing system and provides a high accurate and reliable solution to operate the railway gates.

## 2. EXISTING SYSTEM

In India the Railway Crossing stations are manually operated by the railway gate operator. The railway gate operator is responsible for operating the gates according to the train arrival and departure. The Train arrival and departure information is sent to the gate operator by using the communication devices. The present system is very error prone and which leads to many accidents at railway level crossings. The train information is shared from one crossing system to another when the train leaves the crossing station.

Over 50% of train accidents occur at railway level crossings due to many errors present in the existing system used by the Indian Railways. The method adopted by the Indian railway system is not safe and which is causing more accidents every year.

## 3. PROPOSED SYSTEM METHODOLOGY

We proposed a reliable System which can reduce the number of accidents occurring at railway level crossings

and reduce the time which the vehicles have to wait at crossing stations. In our system we use 4 ultrasonic sensors and a pair of ultrasonic sensors are used to detect the train arrival in both the directions and the other pair of sensors are used to detect train departure in both the directions.

In India there are many types of rails travelling on the railway track daily like goods, passenger and express etc , the maximum speed of a train is approximately 97Km/Hr and the minimum speed of a train is approximately 50 Km/Hr . By considering all the trains types and train speeds the Ideal distance to detect the train by Ultrasonic sensors is about 6Km to 7Km from the crossing station and similarly the Ideal distance to detect the train departure by ultrasonic sensor is about 2Kms to 3Kms from the railway crossing.

The System is composed of Ultrasonic sensors, Servo Motors, LED Signals , Buzzer , Arduino Microcontroller and NodeMcu Wi-Fi module.

The Ultrasonic sensors are used to detect the train arrival and departure. The Servo Motors are used to open and close the railway gates. The LED lights are used as traffic signals at railway crossing and the Buzzer signal is used to warn the vehicles about the train arrival.

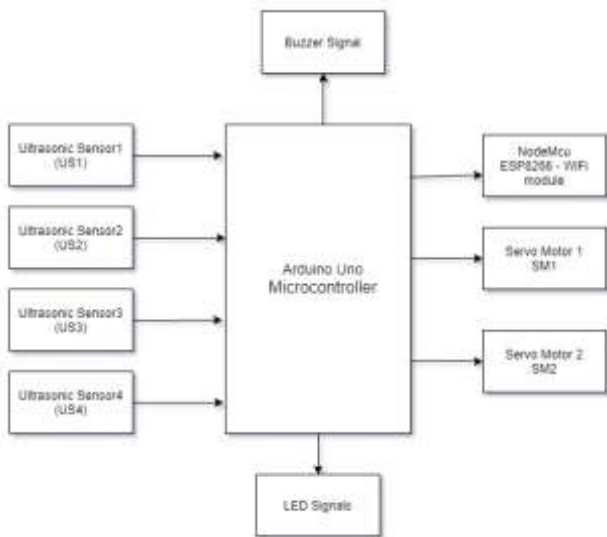

Fig 1. Block diagram of proposed system.

The proposed system uses the ultrasonic sensor to detect the train arrival and which is to be placed at a distance of 7 kms from the railway crossing , when the train is detected by the arrival sensor and it sends signal to microcontroller to perform the following operations sequentially, the passengers at the level crossing are warned with buzzer signal and the LED signal turns to RED and the the railway gates to closed. In the same way when the train leaves the

station the departure ultrasonic sensor detects the train departure and it sends a signal to the microcontroller to perform the following operations sequentially , stops the buzzer signal , turns Green LED signal and opens the railway gates. Whenever the ultrasonic sensor detects the train it will update the train status to the IoT cloud platform. If the arrival ultrasonic sensor detects the train then the train status is updated as 1 by the NodeMcu in cloud. If departure ultrasonic sensor detects train then the train status is updated as 0 in cloud by NodeMcu.

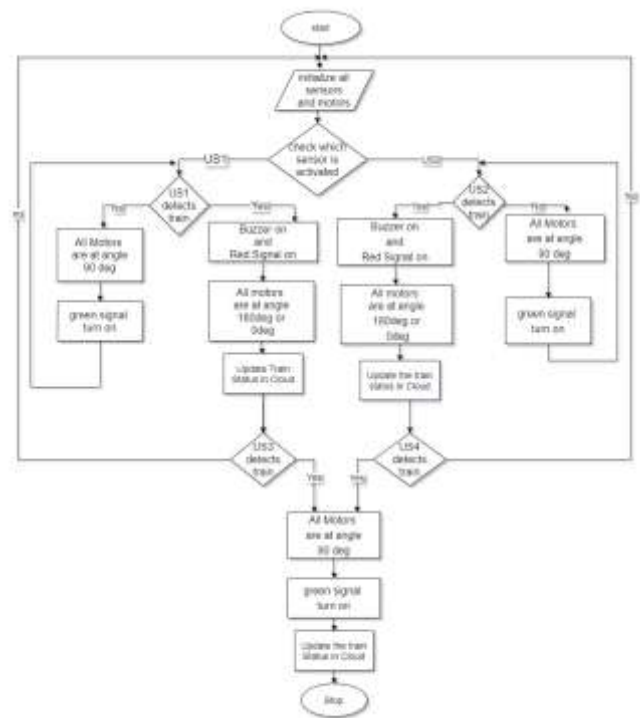

Fig 2. Flow chart shows working of the proposed system.

Figure 2 shows the working of the proposed system for Automated railway crossing system using IoT. In this system the two arrival sensors US1 and US2 are continuously checked for the train arrival if it is detected then the following operations are performed, buzzer signal and red LED signals are turned on, closes railway gates, and updates train status to cloud as 1. The departure sensors US3 and US4 checks for the train departure if the train is detected then the following operations are performed, turn off buzzer signal, turn on green LED and open railway gates.

The Algorithm for Proposed system (Automated Railway crossing system using IoT) working:

**Step1:** Start

**Step2:** Turn on all ultrasonic sensors and railway gates are opened (at 90 degrees).

**Step3:** Continuously check the arrival ultrasonic sensors (US1 and US2 ) for train detection.

**Step4:** If any one of the arrival ultrasonic sensors i.e US1 or US2 detects train then goto **Step5** else goto **Step3**.

**Step5:** Activate the buzzer signal, turn On RED LED signal , close the railway gates (motors are at angle 0deg) and update train status as 1 in cloud.

**Step6:** Continuously check the departure ultrasonic sensors (US3 and US4) for train detection.

**Step7:** If any one of the arrival ultrasonic sensors i.e US1 or US2 detects train then goto **Step8** else goto **Step6**.

**Step8:** Deactivate the buzzer signal, turn on the GREEN LED signal, open the railway gates (motors are at angle 90deg) and update train status as 0 in cloud. goto **Step3**.

As the system is fully automated we develop a web application which is used to display the train arrival and departure information of the train travelling in that track. There will be a control room which keeps track of all trains data and analyzes them using the web application. The web application will be accessible to only authorized users by the railway. We will provide the login credentials to the authorized person who monitors the train data.

#### 4. RESULTS AND ANALYSIS

Figure 3 shows the developed model. The model includes arduino, NodeMcu ESP8266, ultrasonic sensors, servo motors, LED lights and buzzer. The arduino component controls and coordinates all the other components. The arduino sends the train status to NodeMcu by using serial communication and the NodeMcu will update the train status to the IoT cloud platform.

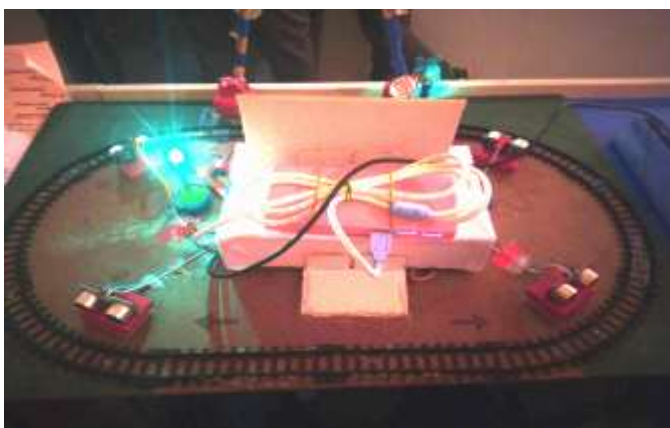
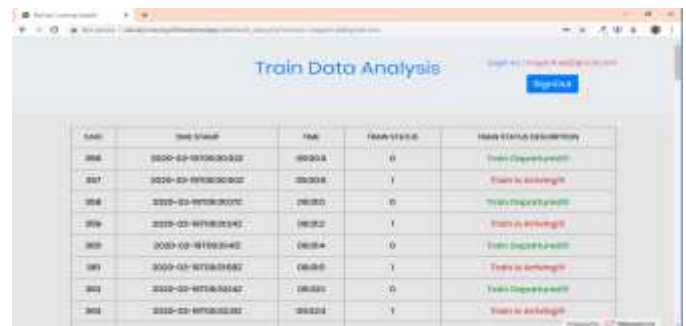

Figure 4 shows the output of the serial monitor of NodeMcu. Here we used the thingspeak IoT cloud platform to store the train status. To upload the train status to thingspeak there will be a minimum 15 seconds delay for each transaction.



Fig 4: Output on Serial Monitor.

Figure 5 shows the web application which displays the train data which include the unique timestamp for each transaction the time which the train is detected by the sensor and the train status which will be 1 if the train arrives at the station or it will be 0 if the train departs the station.



ID	Time Stamp	ID	Train Status	Train Status Description
386	2020-03-07T08:30:32	38388	0	Train Departed successfully
387	2020-03-07T08:30:32	38388	1	Train is arriving
388	2020-03-07T08:30:32	38388	0	Train Departed successfully
389	2020-03-07T08:30:32	38388	1	Train is arriving
390	2020-03-07T08:30:32	38388	0	Train Departed successfully
391	2020-03-07T08:30:32	38388	1	Train is arriving
392	2020-03-07T08:30:32	38388	0	Train Departed successfully
393	2020-03-07T08:30:32	38388	1	Train is arriving

Fig 5: web application showing train data analysis.

#### 5. CONCLUSION

Automated railway crossing system using IoT is an effective and best solution to the problems occurring in the manual system used by the Indian railways. This System provides high benefits to the road users and railway management. This system reduces the accidents which are occurred at railway crossings and reduces the waiting time of vehicles at railway crossing to maximum extent. As this system does not need any human resources it can be implemented in any remote areas and rural areas where there is no railway gate keeper. The proposed system uses the servo motors to lift the gates and these are very reliable and accurate to lift or down the gate by the specified angle rotation. Finally we will conclude that the proposed system will have high reliability, high performance and low cost compared to the existing system which is presently in use.

#### REFERENCES

1. Xishi Wang, Ning Bin, and Cheng Yinhang. A new microprocessor based approach to an automatic control system, International Symposium on Industrial Electronics, pp. 842-843, 1992.

2. Acy M. Kottalil, Abhijith S, Ajmal M M, Abhilash L J, Ajith Babu. Automatic Railway Gate Control System, International Journal Of Advanced Research In Electrical, Electronics and Instrumentation Engineering, Volume 3, Issue 2, February 2014.
3. Ahmed Salih Mahdi, Al-Zuhairi. Automatic Railway Gate and Crossing Control based Sensors and Microcontroller, IN International Journal of Computer Trends and Technology (IJCTT) Volume 4 Issue 7 July 2013.
4. Hnin Ngwe Yee Pwint, Zaw Myo Tun, Hla Myo Tun. Automatic Railway Gate Control System Using Microcontroller, International Journal of Science, Engineering and Technology Research( IJSETR), Volume 3, Issue 5, May 2014.
5. C.Chellaswamy, Srinidhi Srinivasan, R Ramesh Babu. A Humanitarian Intelligent Level Crossing Controller Utilizing GPS and GSM, 2014 IEEE Global Humanitarian Technology Conference- South Asia Satel- lite (GHTC-SAS) September 26- 27, 2014. Trivandrum.
6. Karthik Krishnamurthi, Monica Bobby, Vidya V, Edwin Baby. Sensor Based Automatic Control Of Railway Gates, International Journal of Advanced Research in Computer Engineering and Technology (IJARCET) Volume 4 Issue 2, and February 2015.