

INTERLEAVED HIGH STEP-UP DC-DC CONVERTER USING RENEWABLE ENERGY SOURCES

Udayanan Ramasami¹, Sivakumar Ravindran², Sakthivel Rajakumar³, Raja rajan.R⁴,
Rishikumar.N⁵

¹Assistant Professor, Department of Electrical and Electronics Engineering, Anjalai Ammal Mahalingam Engineering College, kovilvenni, India

^{2,3,4,5}P.G. Student, Department of Electrical and Electronics Engineering, Anjalai Ammal Mahalingam Engineering college, kovilvenni, India

Abstract –This paper presents a new interleaved high step-up DC-DC converter is proposed for distributed generation systems. That combines coupled-inductor and switched-capacitor, the proposed converter achieves very high step-up voltage gain without high turns ratio. High boost dc-dc converters play an important role in renewable energy sources such as fuel energy systems, DC-back up energy systems for UPS, high-intensity discharge lamps and automobile applications. Current stress and input current ripple also reduced by the alignment of the proposed converter, The coupled inductors can be designed to extend step-up gain, and the switched capacitors offer extra voltage conversion ratio and the efficiency is improved. The high step-up conversion may require two-stage converters with cascade structure for enough step-up gain, which decreases the efficiency and increases the cost. Thus, a high step-up converter is seen as an important stage in the system. A prototype with the input voltage developed by more than 10 times to verify the theoretical analysis

Key Words: interleaved, Coupled inductor, high step-up converter, voltage multiplier module, voltage booster.

1. INTRODUCTION

Distributed generation (DG) systems have attracted substantial observation in recent years. The integration of renewable energy into DG systems is becoming increasingly important. The renewable sources, such as Wind energy, thermoelectric cooling(Peltier) , Microbial Fuel Cells. Generate low output voltage, typically 20V-40V. Such low-level voltage needs to be boosted to a high DC-bus voltage (380V or 400V) for grid connection[1]-[2]. Therefore, a high step-up dc-dc converter with high efficiency is required in these systems. The conventional boost converter is not suitable for high step-up applications due to the extreme duty-cycle operation, which results in high power losses. Various boosting techniques have been proposed to achieve high step-up conversion[5]. Switched capacitor (SC), also known as voltage multiplier (VM) or charge pump, is one approach to extend the voltage gain. Step-up converters combining the boost-type structure with Cockcroft-Walton (CW) multiplier, Dickson multiplier, voltage doublers or other diode-capacitor cells have been introduced in the literature[6]. extended by increasing the number of cells.

However, a large number of diodes and capacitors are needed in high step-up applications, which increases the cost and degrades the efficiency. Besides, these topologies may suffer from diode reverse recovery and EMI problems. Additional components may be needed to handle this issue.

Utilizing magnetic coupling provides an extra degree of freedom for high step-up converters [7]. Voltage gain can be extended by increasing the turns ratios. However, the leakage inductance of the coupled inductor or the transformer may result in large voltage spikes across the switches, which causes high voltage stress and degraded efficiency. As a result, converters with passive or active clamp were proposed to handle the leakage problem. In applications requiring a very high conversion ratio, these converters have to use high turns ratio to obtain a large voltage gain. High turns ratio can reduce the efficiency and increase the size of the magnetic [8]. Also, it may result in a very large current ripple. Integrating coupled inductor and switched capacitor is an attractive approach for high step-up converters. Voltage gain is extended by both the turns ratio and the switched capacitor cells. Meanwhile, leakage energy can be recycled with the aid of the switched capacitor cells and diode reverse recovery can be alleviated by the leakage inductance. Due to the single-phase structure, the coupled inductor causes pulsating input current, Thereby, an input filter is needed, which increases the size and cost. Interleaving techniques can be employed to minimize current ripple, reduce the size of magnetic, and increase the current level. interleaved high step-up converters were proposed by integrating the interleaved boost converter with VM modules[10]. High voltage gain, low switch voltage stress, and low input current ripple can be achieved. In a converter combining modified interleaved boost and VM module was proposed. a converter integrating coupled inductors with two voltage-double modules was proposed. These two converters also utilizes input-parallel and output-series connection to reduce the current ripple and extend the voltage gain. But they do not have a common ground between the input and the output. A three-state switching converter mixed with magnetic coupling and VM module was proposed in, Unfortunately, the currents through the two coupled inductors are not balanced. An interleaved high step-up converter with an active clamp circuit was proposed in Zero-voltage switching of the switches and zero-current.

2. BLOCK DIAGRAM

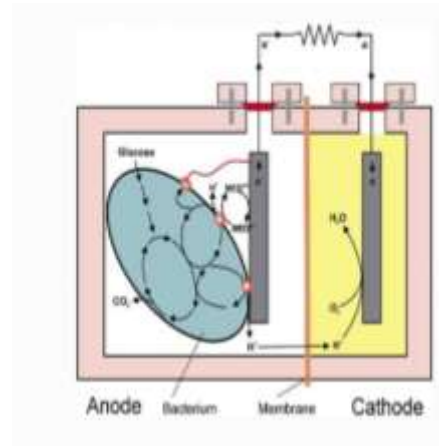
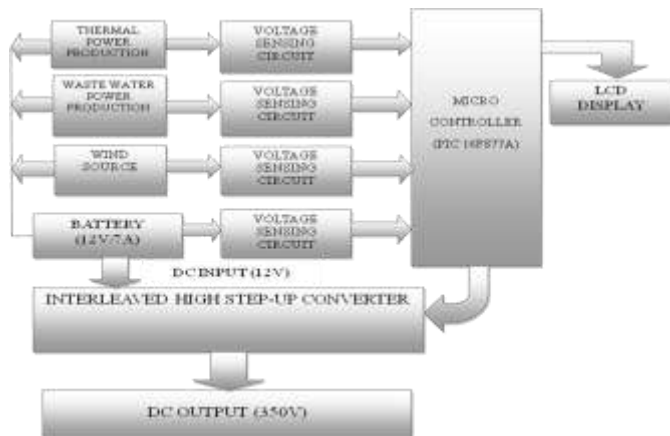

Fig-2: Microbial Fuel Cells

2.1 THERMAL POWER PRODUCTION

A Peltier module is a semiconductor-based electronic component. The temperature differential of the two sides of the module is used to generate electricity. Fig-1 shows the Peltier module. By applying a low voltage DC power to the module from one side to the other. One face will be cooled while the opposite face it simultaneously heated. That this phenomenon may be reversed. By change in the polarity of the applied Dc voltage will cause heat to be moved in the opposite direction. Consequently, both heating and cooling operations are possible thereby making it highly suitable for precise temperature control applications.



Fig-1: Peltier module

2.2 POWER PRODUCTION FROM WASTEWATER BY USING MICROBIAL FUEL CELLS (Fig2)

A microbial fuel cell is a power-producing device that converts chemical energy into electrical energy. The action of microorganisms is used to produce electricity. It is a bio-electrochemical system. That uses bacteria as the catalyst to oxidize organic and inorganic matter. An electrode is placed in the wastewater. Generally, Bacteria grow on it. These bacteria are transforming the organic compounds present in the water into electricity. The wastewater is purified by This process, which is one useful application. Bio-catholyte had also lower internal resistance, and it improved the current generation; maximum COD removal and desalination rate were 80% and 0.38 g NaCl L⁻¹ h⁻¹, respectively. On the removal and desalination rate were 73.1% and 0.34 g NaCl L⁻¹ h⁻¹ respectively.

2.3 POWER PRODUCTION FROM WIND ENERGY

Wind turbines convert the kinetic energy from the rotation of the turbine by the wind flow into mechanical power. This mechanical power can be used for specific tasks generator can convert this mechanical power into electricity to power homes, businesses, schools. Fig-3 shows small-scale wind turbines. The small-scale wind turbines are used to power generation at a household level. A small-scale wind turbine consists of a generator, a power electronic converter, and a control system. And permanent magnet (PM) generator is widely used because of its high reliability and simple structure. depends on the required output power and cost of the system. The power electronic converter topology used.



Fig-3: wind turbine

2.4 PIC 16F877A MICROCONTROLLER

It is a High-performance RISC CPU. TO learn All single-cycle instructions except for program branches which are two-cycle. Operating speed: DC - 20 MHz clock input DC - 200 ns instruction cycle. Up to 8K x 14 words of FLASH Program Memory, Up to 368 x 8 bytes of Data Memory (RAM). Up to 256 x 8 bytes of EEPROM Data Memory.



Fig-4: Pin diagram of 16F877A

3. ENTIRE CIRCUIT DIAGRAM

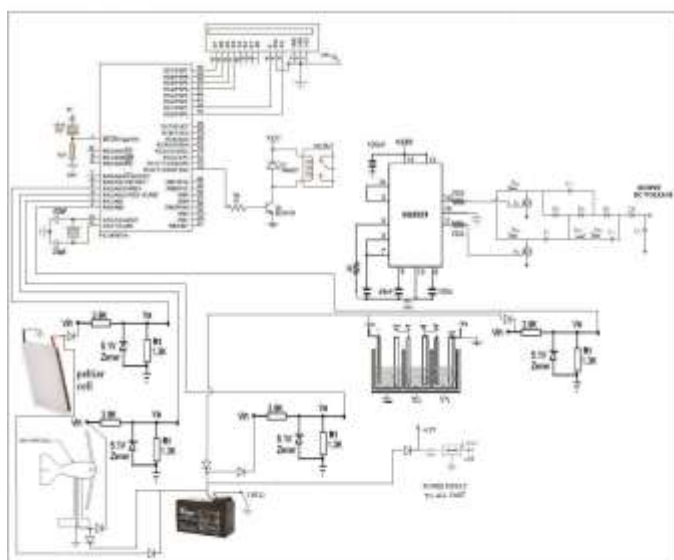

Fig-5: circuit diagram

The generalized structure of the proposed converter is shown in Fig-4. It is composed voltage multiplier circuit, three energy sources (wind, Peltier, microbial fuel cells) and one output monitor. In the voltage multiplier circuit, The primary windings of the coupled inductors are connected in parallel and the secondary windings are connected in series. Both coupled inductors are modeled as an ideal transformer with magnetizing inductance and leakage inductance. The two switches of the proposed converter are driven in an interleaved manner. The structure of the proposed converter is shown in Fig-6. It comprises an interleaved voltage-doubler boost converter and multiple winding-based switched capacitor (WSC) cells. Each WSC cell has two diodes, two capacitors and two windings of the coupled inductors. Fig-7 shows the basic topology with one WSC cell. It is composed of two coupled inductors, two switches, four diodes, three energy transfer capacitors, and one output capacitor. The primary windings of the coupled inductors are connected in parallel and the secondary windings are connected in series. The turns ratios of the coupled inductors are the same.

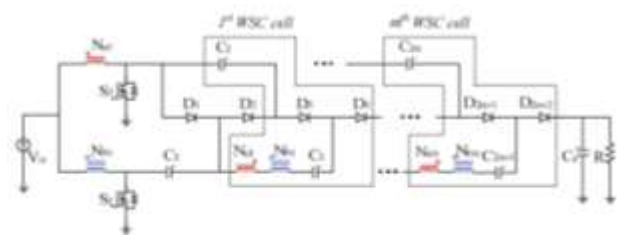

Fig-6: structure of the proposed converter

The below Fig-7 shows the voltage multiplier circuit, which is used to boost up the voltage from given 12 volt to 350 volt. The duty cycle D during steady-state is larger than 0.5. In this paper, the operation in continuous conduction mode (CCM) is discussed.

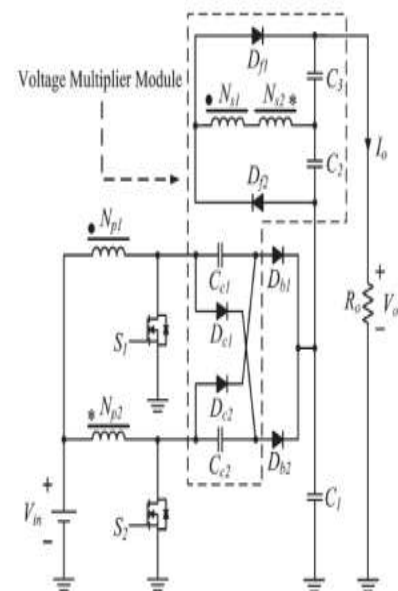

Fig-7: voltage multiplier circuit

The equivalent circuit of the proposed converter is shown below Fig-8. where L_{m1} and L_{m2} are the magnetizing inductors; L_{k1} and L_{k2} represent the leakage inductors; L_s represents the series leakage inductors in the secondary side; S_1 and S_2 denote the power switches; C_{c1} and C_{c2} are the switched capacitors; and C_1 , C_2 , and C_3 are the output capacitors.

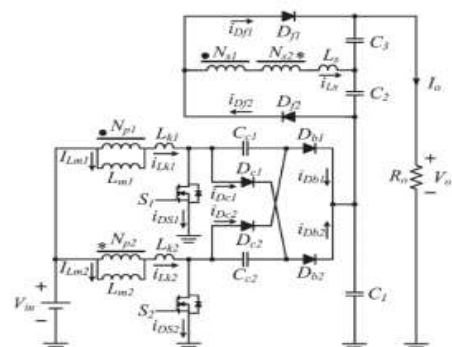

Fig-8: Equivalent circuit

4. MODES OF OPERATIONS

According to the operation of S1 and S2, there are eight operating modes when operates in the continuous conduction mode (CCM). Fig.9 represents several key waveforms of one cycle. And Fig-10 represents the equivalent circuit of the converter in different modes.

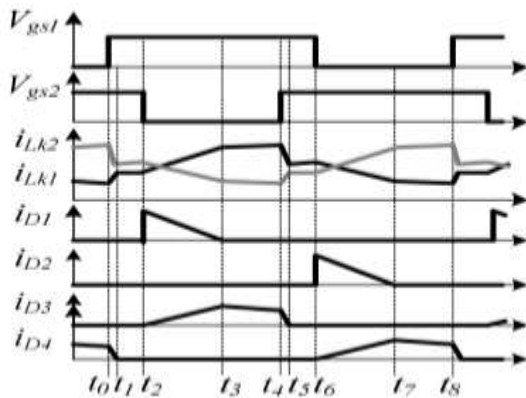

Fig-9: key waveform of one cycle

Mode I [t0~t1]: At the time of t0, S1 is switched on, the S2 maintains the state of conducting. Because the current of the inductor can't be changed suddenly, the diode D4 is still on. The current through the diode D4 decreases gradually. When the iD4 is reduced to zero, D4 is turned off under ZCS.

Mode II [t1~t2]: At the time of t1, S1 and S2 are switched on. All diodes are reverse biased. During this transition, Lm1, Lm2, Lk1, and Lk2 are charged linearly by the input power. The energy of load is provided by the two output capacitors. Mode III [t2~t3]: At the time of t2, the S2 is switched off, S1 maintains the state of conducting. Diodes D1 and D3 are on. Part of the energy stored in Lk2 is transferred to C1 via D1. The input voltage, coupled-inductors, and VC2 are in series to charge the capacitor C4, extending the voltage gain of this converter. The current iLk2 begins to decrease. At the same time, the current iD1 is decreased gradually. D1 is turned off under the ZCS condition.

Mode IV [t3~t4]: At the time of t3, D1 is turned off, as shown in Fig. 2(d). Lm1 and Lk1 are charged linearly by the input dc source. C4 is still charged through Lm2, Lk2, and C2. The load current is provided by C3. off. In this mode, S1 and S2 are switched on. The energy of load is provided by the capacitors C3 and C4.

Mode VII [t6~t7]: At the time of t6, the S1 is switched off and S2 continues to be turned on. Diodes D2 and D4 are turned on. Part of the energy stored in Lk1 is transferred to C2 via D2. The leakage inductor energy is reclaimed by C2, which can be used to reduce the losses. Another part of the energy stored in Lk1 and the energy stored in C1 are transferred to C3 via D4. The current iLk1 begins to decrease. At the same time, the current iD2 is decreased

gradually. The current of D2 drops to zero and it is turned off under ZCS, and this mode ends.

Mode VIII [t7~t8]: At the time of t7, D2 is turned off. In this mode, Lm2 and Lk2 are charged linearly by the input voltage. C3 is charged by Lm1, Lk1, and C1.

4.1. VOLTAGE CONVERSION CIRCUIT

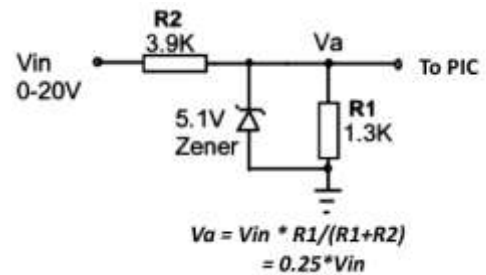

Therefore the input voltage ranging from v in=0-20v Is scaled down to the output va =0-5v.

5. EXPERIMENTAL RESULTS

A prototype with 12V input and 350V output was built to verify the performance of the proposed converter. The key parameters of the prototype are listed as in Table1 A picture of the prototype is shown in Fig.10.

Fig.11 shows that the input voltage is 20V and the output voltage is 400V. Therefore, high voltage gain is achieved even when the turns ratio is 1.

Fig.12 shows the voltages of the diodes. As can be seen, the blocking voltages of D1 and D2 are around 136V and the blocking voltages of D1 and D2 are around 268V.

Fig.13 shows the currents through the diodes. It can be seen that the reverse recovery problems of the diodes are alleviated due to the existence of the leakage inductances.

Table1: key parameters of the prototype

parameters	Value/description
Input voltage = 1:1	20V
Output voltage	400V
power	320W
Switching frequency	50kHz
Switches S1-S2	IPA075N15N3 (150V)
Diodes D1, D2	STPS20200CT (200V)
Diodes D3, D4	TST20H300CW(300V) Turns ratio= 1:1
Coupled inductors	Magnetizing inductance = 100uH Leakage inductance = 3.5uH

Capacitor C_1	22 μ F Film capacitor
Capacitor C_2, C_3	8.2 μ F Film capacitor
Capacitor C_0	2200 μ F electrolytic capacitor

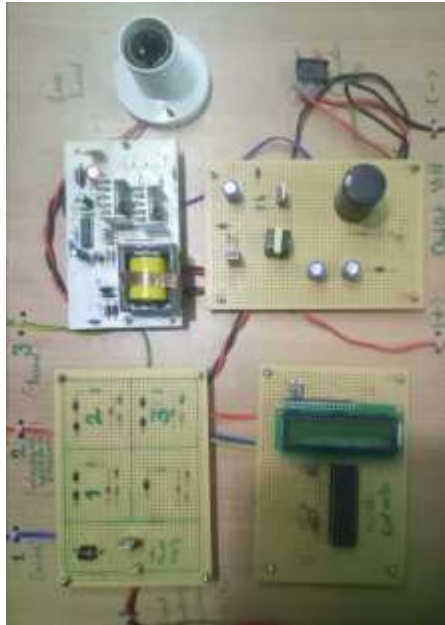

Fig.10: picture of the prototype

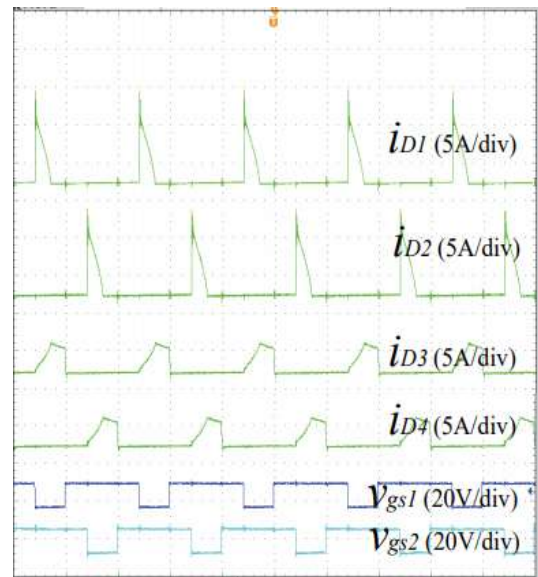

Fig.13: current across the diode

Fig-14 shows the voltages across the capacitors. It can be seen that V_{c1} , V_{c2} , and V_{c3} are around 68V, 136V and 200V, respectively, which are consistent with the calculations from

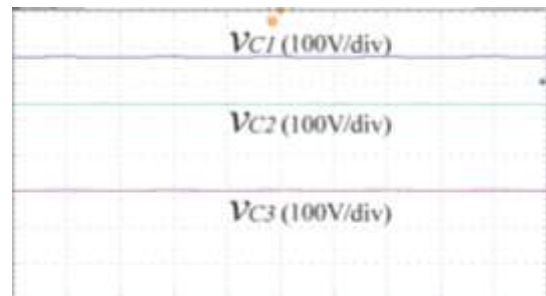

Fig.14: Voltages across the capacitors.

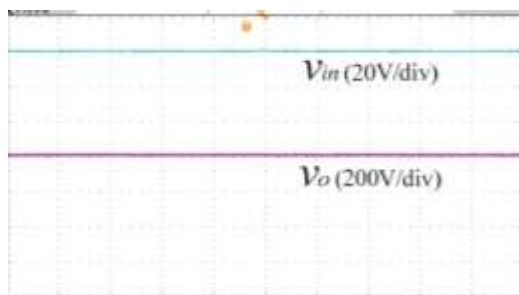

Fig.11: The input and output voltages

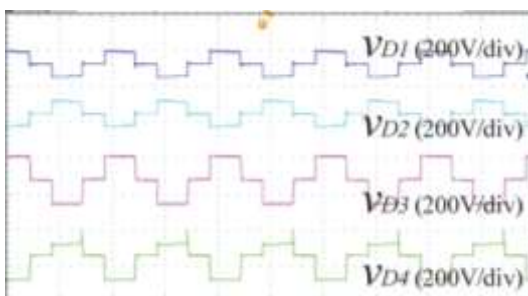

Fig.12: Voltages across the diodes

6. CONCLUSION

An interleaved high step-up converter integrating coupled-inductor and switched-capacitor techniques has been proposed in this paper. It is shown that very high step-up voltage gain is achieved without an extreme duty cycle or high turns ratio. Also, due to the low switch voltage stress, low-voltage-rating MOSFETs with small on-resistance are allowed to reduce the conduction loss. Furthermore, low-ripple continuous input current is achieved thanks to the interleaved operation at the input side. Moreover, ZCS turn-on of the switches is achieved and the reverse recovery problem of the diodes is alleviated. Also, the leakage energy is recycled. The operation principles and characteristics of the basic topology were analyzed in detail. A 20V-input and 400V-output prototype was built. Experimental results have verified the theoretical analysis.

REFERENCES

- [1] W. Li and X. He, "Review of Non isolated High-Step-Up DC/DC Converters in Photovoltaic Grid-Connected Applications," in IEEE Transactions on Industrial Electronics, vol. 58, no. 4, pp, April 2011.

- [2] J. M. Carrasco et al., "Power-Electronic Systems for the Grid Integration of Renewable Energy Sources: A Survey," in *IEEE Transactions on Industrial Electronics*, vol. 53, no. 4, pp. 1002-1016, June 2006.
- [3] G.Karthikeyan M.E, V.S .Sowmiya, R.Ramya "Smart Grid Incorporated With Boost Converter Based Micro Inverter Topology", in *IJRAR* vol.6,no. 360, Feb.2019.
- [4] Ebrahimi, Atieh; Najafpour, Ghasem D; Yousefi Kebria, Daryoush (2018). "Performance of microbial desalination cell for salt removal and energy generation using different catholyte solutions". *Desalination*. **432**: 1-9. doi:10.1016/j.desal.2018.01.002
- [5] M. Forouzesh, Y. P. Siwakoti, S. A. Gorji, F. Blaabjerg and B. Lehman, "Step-Up DC-DC Converters: A Comprehensive Review of Voltage-Boosting Techniques, Topologies, and Applications," in *IEEE Transactions on Power Electronics*, vol. 32, no. 12, pp. 9143-9178, Dec. 2017.
- [6] Bassett, R. J.; Taylor, P. D. (2003), "17. Power Semiconductor Devices", *Electrical Engineer's Reference Book*, Newnes, pp. 17/1-17/37, ISBN 0-7506-4637-3
- [7] Longoria, R.G.; Kypuros, J.A.; Raynter, H.M. (1997). "Bond graph and wave-scattering models of switched power conversion". 1997 IEEE International Conference on Systems, Man, and Cybernetics. *Computational Cybernetics and Simulation*. **2**. pp. 1522-1526. doi:10.1109/ICSMC.1997.638209. ISBN 978-0-7803-4053-4.
- [8] Singh, Yaduvir (2011). *Electro Magnetic Field Theory*. Pearson Education India. p. 65. ISBN 978-8131760611
- [9] Y. T. Chen, Z. X. Lu and R. H. Liang, "Analysis and Design of a Novel High-Step-Up DC/DC Converter With Coupled Inductors," in *IEEE Transactions on Power Electronics*, vol. 33, no. 1, pp. 425-436, Jan. 2018.
- [10] Taylor, R.A.; Solbrekken, G.L. (2008). "Comprehensive system-level optimization of thermoelectric devices for electronic cooling applications". *IEEE Transactions on Components and Packaging Technologies*. **31**: 23-31. doi:10.1109/TCAPT.2007.906333