

# Design and Experimental Testing of a Two-Terminal Mass Device with a Variable Moment of Inertia Flywheel

Y. R. Patil<sup>1</sup>, Kishor Bhandare<sup>2</sup>

<sup>1,2</sup> Department of Mechanical Engineering, Dr. J.J. Magdum College of Engineering, Jaysingpur (Maharashtra State), India.

\*\*\*

**Abstract** - Conventional vehicle suspensions consist of a spring and a damper, while mass is rarely used. A mass, if properly used, can also create a damping-like effect. However, a mass has only one terminal which makes it difficult to be incorporated into a suspension. In order to use a mass to achieve the damping-like effect, a two-terminal mass (TTM) has to be designed. However, most of the reported TTMs are of fixed moment of inertia (TTM-CMI), which limits the further improvement of the suspension performance and responsiveness to changes in environment and driving conditions.

In this study, a TTM-based vibration absorber with variable moment of inertia (TTM-VMI) is proposed. The main component of the proposed TTM absorber contains a hydraulic-driven flywheel with sliders. The moment of inertia changes with the positions of the sliders in response to the driving conditions. The performance of the proposed TTM-VMI absorber has been analyzed via dynamics modeling and simulation and further examined by experiments. The analysis results indicate that the TTM-VMI absorber outperforms the TTM-CMI design in terms of body displacement; and ride comfort, tire grip and suspension deflection for zero and impulse inputs with comparable performance for sinusoidal input.

**Key Words:** variable moment of inertia, two terminal mass device, shock absorber.

## 1. INTRODUCTION

The system for automobile shock absorber includes mainly springs, dampers and connectors, connecting an automobile towards rolls and allowing comparative movement between them, the suspensors are having objective that adds to street holding, braking also management of excellent driving enjoyment of the vehicle and actively safeguarding and also maintaining the occupants of the cars relaxed and fairly fine protected against road disturbances and oscillations.

Automobile suspensor system is seen as a mechanical structure that consists mass, spring, and damper. These fundamentals are having double terminuses, then one terminus is ground of the mass the other terminus remains place for midpoint of mass himself because, Second Law of Newton's refers to accelerating body relation with

immovable theme within inertial surroundings, this was an crucial limited to body persistence within suspensor also oscillation damper.

During car roll strikes hump that suppresses suspensor, A section of vibratory power produced through striking hump remains deposited within suspensor. afterwards a hump the deposited power should be flown backwards. Hence resulting, since a car is not prepared with a suspensor, the suspensor will carry the way upwards and downwards afterwards striking hump. another way, this section of power leading automobile fluctuation this is clearly objectionable. A suspensor diffuses the power produced from car fluctuation and then prevents the suspensor against wavering towards stipulated period.

Mostly the present suspensors were made of hydraulics damping they suppress the fluctuations into heat through dispersing vitality of vibration. Thus, power was unused. In this project work learning is focused in the way for the development of a innovative mass-based suspensor to conquer the swinging deprived of unused power and in the meanwhile progresses the suspensor act.

## 2. LITERATURE REVIEW

An automobile suspensor system was used for guiding with an automobile road surface holding, braking, handling, sustain drive comfortness and segregation against road bumps, vibration, noise. Spring and shock absorber are the primary elements of the vehicle suspensor scheme. Researchers have made various efforts to expand present suspensor system.

### 2.1 TWO TERMINAL MASS SYSTEM

The power current relationship functions admirably on account of damper and spring, yet there confinement of mass can't overlooked dependent on Second Law of Newton on grounds that speeding up of the mass is with respect to a static point in the inertial edge. All the exactly, normal mass was just a single veritable terminal, at focal point mass the other terminal was condition. Interference of mass with power and position along with nature over this pounded terminal. The issue is for electrical-circuit could has an immediate spring-mass-damper simple just on the off chance

that capacitors one terminal is grounded in this electrical circuit.

The mass component's other disadvantage is that, simple mechanical impedances of framework is the capacitor. This might be imperative for expecting, mechanical gadget related along with "discovery impedance" had irrelevant contrasted mass with different framework masses. Aimed at instance, a suspensor swag for automobile thinks about to un-sprung as well as sprung masses. Clearly, this is a non-unimportant issue if huge masses are required for its acknowledgment. Another gadget inerter for two-terminal mass is created for taking care of issues.

**Table-1:** Two-Terminal typical mass transmission core

External Terminal Relative motion	Mass core	Motion transformation	Transmission mechanism
Rectilinear	Mass-block	Rectilinear to Rectilinear	Lever
Rectilinear	Mass-block	Rectilinear to Rectilinear	Hydraulic
Rotary	Mass-block	Rotary to Rectilinear	Screw
Rotary	Mass-block	Rotary to Rectilinear	Gear-Rack
Rectilinear	Fly-wheel	Rectilinear to Rotary	Hydraulic
Rectilinear	Fly-wheel	Rectilinear to Rotary	Rack-Gear
Rotary	Fly-wheel	Rotary to Rotary	Gear
Rotary	Fly-wheel	Rotary to Rotary	Hydraulic

### 3. MODELLING OF CYLINDER

Modeling of parts is carried out by using CATIA V5 R16 software. IGS model of parts is developed which is used for analysis. IGS model developed is imported in Ansys for further study purpose.

Geometry

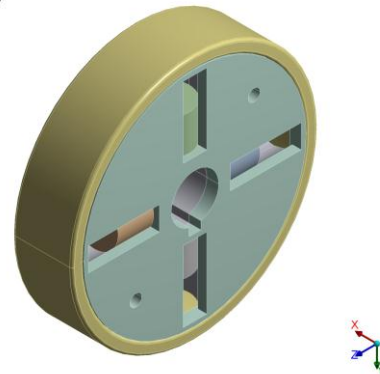

### 4. Twice Terminus VMI Hydraulic fly-wheel Structure (Passive)

For its proposal, another twice terminus VMI water driven fly-wheel framework was planned utilizing for a model appeared at stage. This plan includes another fly-wheel with variable snapshot of idleness when it pivots, bringing about an adjustment in the dormancy of the whole framework, henceforth the name of the water driven fly-wheel framework's two-terminal variable snapshot of inactivity (VMI). The subtleties of this fly-wheel are talked about in this subsection.

The structure graph of the fly-wheel as appeared in Figure. about its outline, just four masses means sliders were used for fly-wheel. Addition of masses may be placed amongst fly-wheel if we require higher variational snapshot latency. These progressions existing apart from everything else of inactivity of the fly-wheel is brought about through changing positions of masses during turning of the inertial structure.

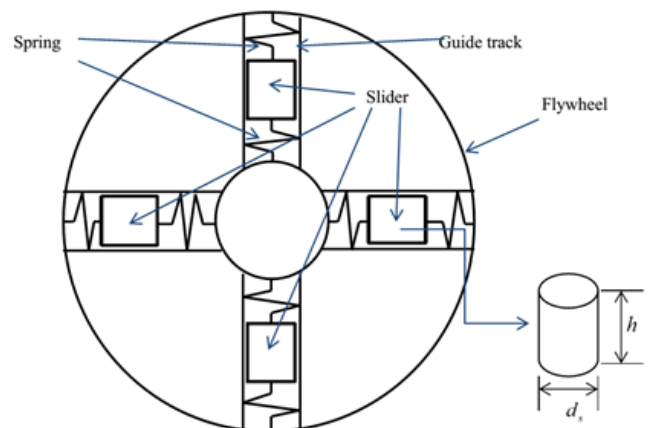

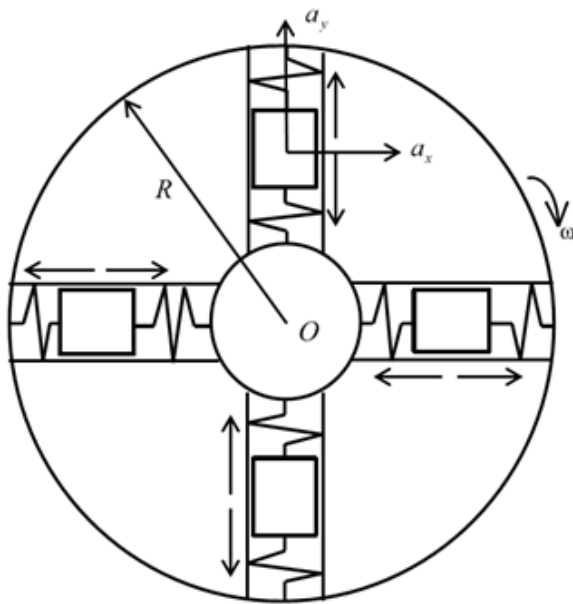

### 5. EXPERIMENTATION

Investigation is the technical examination's record detectible techniques; for range where techniques, including explanation, comparison and modelling. Where as whole methodologies distribute a combined science method, investigation was exclusive in which this includes these deliberate management and observation for convinced components for a genuine structure. Experimenting stretches perception for a structure. For finding the definite outcomes investigation was essential, because we consider the parameters for design purpose are different from the real ones so we need to consider certain assumptions for analysis.

Within our chapter, explanation for fundamentals for investigational circumstance was supplied with investigating procedure and concluded test outcomes. To conduct vibration analysis for undamped dynamic vibration absorber subjected to harmonic stimulation subsequent composition was mandatory.

### 6. Experimental Results

**B: Variable inertia flywheel\_T=1 Nm m**

Total Deformation  
Type: Total Deformation  
Unit: mm  
Time: 1

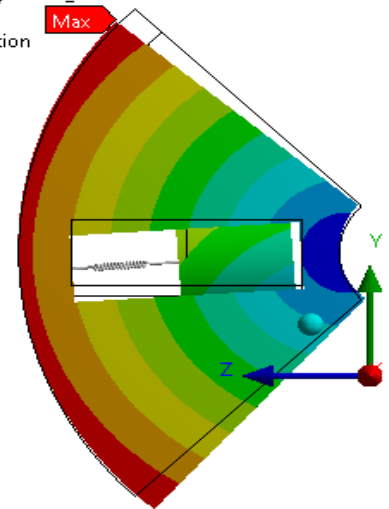
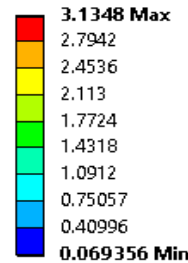

**B: Variable inertia flywheel\_T=1 Nm m**

Moment  
Time: 1. s

Moment: 1. N-mm  
Components: 1.,0.,0. N-mm

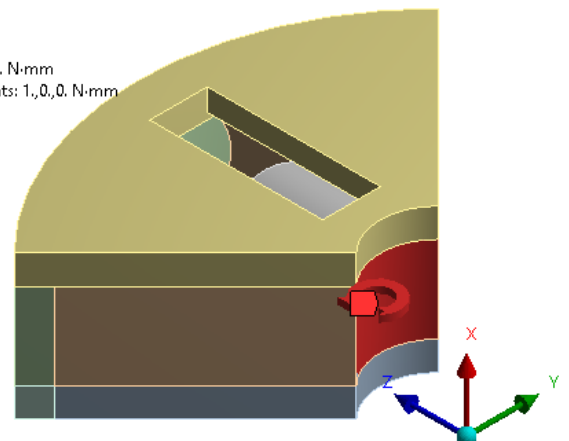

### 7. CONCLUSIONS

The following can be noted from the experimental outcomes:

1. VMI fly-wheel output is between VMI fly-wheel performance with maximum inertia moment and minimum inertia moment. Hence, in case of zero input as well as impulse stimulations the performance of the passive two degree of freedom VMI suspensor must give output superior to CMI suspensor.
2. Counteraction is observed during change of rotational direction of fly wheel. We can reduce the backlash from the system but cannot be eliminated it completely.
3. Some resistance of friction is always present in system hence the response to force was non zero during absence of fly-wheel.

## 8. FUTURE SCOPE

As we know there are some unsolved parameters which can be studied further in the following way:

1. For this study we have designed suspensor for passive non linear type of system. In future the linearization should be done for analytically solution of system. Active system performs better to Passive one.

2. Control over counteraction is essential although we cannot completely eliminate this.

## 9. REFERENCES

- [1] Anderson, B.D.O., Vongpanitlerd, S., 1973, Network Analysis and Synthesis: An Approach to Modern Systems Theory (Englewood Cliffs: Prentice Hall).
- [2] Chuan Li, Jiang Peng, Wang Shilong, Wang Yixian, and Jiao Zaojie, 2011, Design of Novel Hydraulic Flywheels for Vehicle Suspensions. *Advanced Science Letters*, 4(4-5), 1586–1590.
- [3] Li Chuan, Wang Shilong, Kang Ling, Lei Song, Yu Qibing, 2010, Two-Terminal Manipulation of Masses: Application to Vibration Isolation of Passive Suspensions. *Journal of Vibroengineering*, 12(2), 143-155
- [4] Li Chuan, Liang Ming, Wang Yixian, and Dong Yutao, 2011, Vibration Suppression Using Two-terminal Flywheel Part I: Modeling and Characterization. *Journal of Vibration and Control* accepted, 18(8), 1096-1105
- [5] Li Chuan, Liang Ming, Wang Yixian, and Dong Yutao, 2011, Vibration Suppression Using Two-terminal Flywheel Part II: Application to Vehicle Passive Suspension. *Journal of Vibration and Control* accepted, 18(9), 1353-1365.
- [6] M.C. Smith, G.W. Smith, "Performance Limitations and Constraints for Active and Passive Suspensions: A Mechanical Multi-Port Approach", *Vehicle System Dynamics* 33 (3) (2000)137-168.
- [7] M.C. Smith, F. Wang, "Performance Benefits in Passive Vehicle Suspensions Employing Inerters", *Vehicle System Dynamics* 42 (4) (2004) 235–257.