

## DESIGNING OF RAILWAY SIGNALLING, INTERLOCKING SYSTEM AND CONTROLLING USING PLC WITH SCADA

**Niteesh Kottapalli<sup>1</sup>, Bhargav Koya<sup>2</sup>, Vishal Mulpuri<sup>3</sup>, Mahesh Muthukuri<sup>4</sup>**

*<sup>1,2,3,4</sup>UG Student, Department of Electronics and Communications Engineering, Vasireddy Venkatadri Institute of Technology, Namburu(V), Guntur(Dt), Andhra Pradesh, India*

**Abstract** - This project illustrates a design a of railway signaling and interlocking with enhanced safety system PLC and SCADA. The Indian railway is considered as the largest railway network in Asia, but there are few drawbacks which can be overcome by using railway signaling and interlocking system. In Indian railways, signaling and interlocking process is not completely automated, but being still managed by railway employees. During train crossing, there are certain works which are required to be done by human interference, which causes problems in railway interlocking system like delay, collision, chain pulling, and passenger etc. Hence, these problems can be solved by applying PLC and SCADA. The main task of interlocking is to provide a route request at suitable managing points and signals, which will not cause any collision. The proposed work is dependent on PLC, which are capable of performing signaling and interlocking process automatically which can even be changed, corrected and observed by using SCADA system, resulting in reduction of human involvement.

**Key words:** SCADA (Supervisory Control and Data Acquisition), PLC(programmable logic controller), Interlocking System.

### 1. INTRODUCTION

The project aims at providing an excellent usage of SCADA facility both in large and small systems. In this project, we focused on building a Railway system provided with an interlocking and Controlling facility via by making use of PLC and SCADA. SCADA can be built in three applications such as in Industrial, infrastructural and Facility-Based processes. Industrial proceses include manufacturing, process control, power generation. Infrastructure processes include water treatment and distribution, wastewater collection and treatment, electric power transmission and distribution. Facility-Based processes, including buildings, airports, ships and space stations they monitor and control everything so that one can able to get to know about the background work of any system if and only if it is designed by using SCADA.

### 2. PROPOSED SYSTEM:

\*\*\*

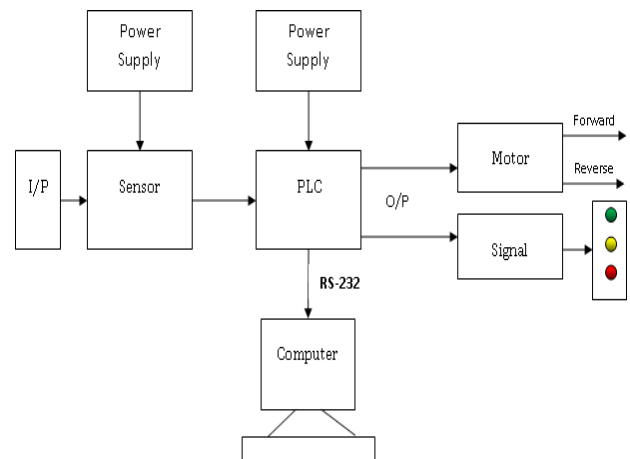

**Fig 2.1: Proposed system**

- By employing the PLC for automatic control of railway trains would decrease the railway traffic and also automating railway gate control at the level crossings.
- The capacity decides the number of trains that can run on a single day and also we can record and store the exact time of arrival and leaving.
- Design of an automated railway signalling and interlocking system using Programic logic controller(PLC) will do all the operations that are performed manually.

### 3. LEVEL CROSSING:



**Fig 3.1Level Crossing**

- A level crossing is an intersection where a railway line crosses a road or path.
- Initially, a variety of signs were posted at crossings, and in time, watchmen were stationed at the busier crossings to warn of approaching trains.

When activated, the lights flash, the bells ring and the barriers lower, as the **crossing** is usually automatic. More rarely, once the barriers fully lowered, the sound changes. For some **level crossings**, when the barriers begin to go up, the square light stops flashing.

**4. INTERLOCKING:**



**Fig 4: Interlocking**

- In railway signalling, an **interlocking** is an arrangement of signal apparatus that prevents conflicting movements through an arrangement of tracks such as junctions or crossings.
- Interlocking is basically mechanical or relay based.
- PLC means Programming Logic Controller and it is a digital computer which stores the data in the form of non-versatile.

Some of the fundamental principal of interlocking include: Signals may not be operated to permit conflicting train movements to take place at the same time on set route. Switches and other appliances in the route must be properly 'set' before a signal may allow train movements to enter that route.

In order to ensure that the signalling system never provides conflicting signals and the points are not set for more than one train that might end up proceeding on to the same section of track and hence suffering a collision, various schemes have been developed to coordinate the settings of the points and the signals within the region controlled by a signalbox or signal cabin.

**4.1 IR SENSOR:**



**Fig 4.1.1 IR sensor**

- An infrared sensor is an electronic instrument that is used to sense certain characteristics of its surroundings.
- Infrared sensors are also capable of measuring the heat being emitted by an object and detecting motion.

**4.2 Relays :**



**Fig 4.2.1: Relays**

A relay is an electrically operated switch. It consists of a set of input terminals for a single or multiple control signals, and a set of operating contact terminals. The switch may have any number of contacts in multiple contact forms, such as make contacts, break contacts, or combinations thereof.

Relays are used where it is necessary to control a circuit by an independent low-power signal, or where several circuits must be controlled by one signal. Relays were first used in long-distance telegraph circuits as signal repeaters: they refresh the signal coming in from one circuit by transmitting it on another circuit. Relays were used extensively in telephone exchanges and early computers to perform logical operations.

**4.3 LIMIT SWITCH**



**Fig 4.3.1: Limit Switch**

A limit switch is an electromechanical device that consists of an actuator mechanically linked to a set of contacts. When an object comes into contact with the actuator, the device operates the contacts to make or break an electrical connection

## 5. SCADA BOARD:



**Fig 5: Scada Board**

- Sometimes it is possible of arriving two trains on same platform. In that cases one train should wait out side the platform.
- This problem can overcome by using Interlocking System.
- PLC automatically navigates the train to on a free platform.
- The figure shows the traditional system used to navigate train which is under the control of station master.

### 5.1 PROJECT CONSTRUCTION:



**Fig 5.1.1: Project Construction**

## 6. CONCLUSION

The Indian Railway is the most widely used transport system in India and also it is the most cost efficient mode of transport. We are thankful to our Siemens project guide A K R. Kotewswara Rao Sir and our academic project guide M. Pardha Saradhi sir for their support and encouragement in finishing up this huge project.

## 7. REFERENCES

- R.Gopinathan and Shivashankar, "PLC Based Railway Level Crossing Gate Control," international journal of emerging technology in computer science & electronics (IJETCSE), ISSN: 0976-1353, Volume 8, Issue 1- April 2014.
- Y.Baba, A.Hiratsuka, E.Sasaki, O.Yamamoto and M.Miyamoto, "Radio-based Train Control System," Hitachi Review, Volume 61, 2012.
- T.ten Hoeve, "Model Based Testing of a PLC Based Interlocking System," Master thesis, University of Twente.
- Allen Bradley MicroLogix 1000, Architecture and Operation, module1.
- O.Eris and I.Mutlu, "Design of Signal Control Structures Using Formal Methods for Railway Interlocking Systems," 11<sup>th</sup> Int. B Conf. Control, Automation.
- 'Simulation of Relay Interlocking Systems' by L. E .Eriksen and B. Pedersen, 2007.