

MAGNETO-RHEOLOGICAL FLUID ASSISTED DAMPER

Devang Labdhe, Chandan Shah², Prathamesh More³, Mr. Krishnagopal Sharma⁴

^{1,2,3}Department of Mechanical Engineering, Pravin Patil College of Diploma Engineering & Technology.

⁴Project guide, Department of Mechanical Engineering, Pravin Patil College of Diploma Engineering & Technology.

-----***-----
ABSTRACT:

In this paper we have discussed and covered up all the points that are required in order to manufacture a damper as well as the magneto-rheological fluid. We have also covered up the differences between the working of conventional dampers and the magneto-rheological fluid assisted dampers. We have also shown the results as to why magneto-rheological fluid based dampers are to be preferred in the near future.

Keywords: rheos, rheological, controllable viscosity, MR effect.

1. INTRODUCTION

The function of a shock-absorber or damper is to control the quick bouncing of the wheels on road for stability and to control the slow bouncing of the vehicle body on suspension springs and this is achieved due to the downward movement of the piston in the cylinder which then forces the fluid inside the cylinder to pass through a hole due to which a resistance to movement of piston is developed which provides the damping effect. The magneto-rheological fluid assisted dampers or more commonly known as MR dampers are mainly used in such automobile applications where the damping required is of such a type where a quick response is required while damping all the shocks experienced by the driver which a conventional hydraulic or pneumatic damper is not able to damp.

The most essential component of a damper is the fluid inside and in this case the MR fluid. The MR or magneto-rheological fluid falls into a class of smart or non-Newtonian fluids whose rheological properties (elasticity, plasticity, or viscosity) change in the presence of a magnetic field. Firstly, considering an example of water, it is a Newtonian fluid, what this means is that it has a linear relationship between its stress-strain rate when in loaded condition, strictly. This also does mean that when water (Newtonian fluid) is subjected to various loads it acts accordingly but its viscosity remains the same meaning it will behave as a normal liquid throughout until the external factors such as temperature are changed. While if an electro or magneto-rheological fluid (non-Newtonian) is concerned it has a non-linear relationship in between its stress-strain rate which means that the viscosity of such fluids tend to change as per the amount of force acting over it, accordingly. The viscosity of the magneto-rheological fluids mainly changes according to the strength of magnetic field around the system. Hence, these types of

fluids are now-a-days majorly used in automobile-braking and suspension systems, heavy body armours, in medical fields too, in prosthetic legs as to reduce to shocks and damp the vibrations experienced by a person.

2. WORKING

A typical magneto-rheological fluid based suspension consists of some very essential components mainly, the cylinder with the MR fluid filled in it and the electromagnet en-grooved inside the piston in order to create a magnetic field inside the cylinder.

Due to such a setup when the voltage across the electro-magnet is low, the resistance to the flow of the magneto-rheological fluid is low too. While, if voltage across the electro-magnet is increased, viscosity of the MR fluid increases which results in increase in the damping force too.

This change in the voltage across the electro-magnet depends upon the terrain over which the vehicle is travelling on. The terrains are sensed by the vehicle with the help of image processing.

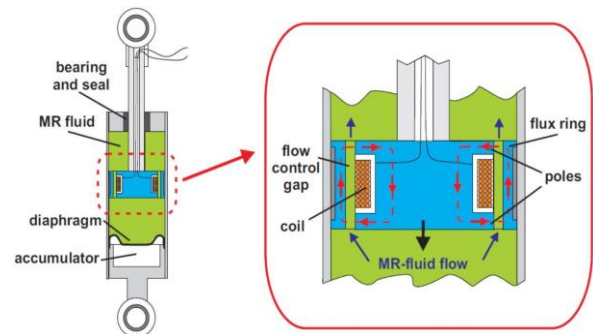

Fig. 1: Basic working of MR dampers

3. CLASSIFICATION OF SUSPENSIONS

1. Conventional suspension system
2. Independent suspension system-
 - I. Independent front end suspension
 - a. Whishbone type
 - b. Mac Pherson strut type
 - c. Vertical guide type

- d. Trailing link type
- II. Independent rear suspension
- 3. Air suspension
 - a. Bellow type air spring
 - b. Piston type air spring
- 4. Hydroelastic suspension
- 5. Rheological suspension

4. TYPES OF MR DAMPERS

- 1. Mono tube
- 2. Twin tube
- 3. Double ended MR damper
- 4. MR-Hydraulic hybrid damper

5. MAGNETO-RHEOLOGICAL FLUIDS

The word ‘rheology’ comes from Greek *rheos*, meaning to flow, or the study of flowing fluids. The subject is mainly concerned with the study of deformation and flow of matter when subjected to external forces.

Hence, it can be considered that a magneto-rheological fluid has a property of changing its flow and resistance to the same when in contact with a magnetic field.

According to the Newton’s law of viscosity, any fluid which obeys the Newton’s law of viscosity is a Newtonian fluid.

That is,

$$\tau = \mu \frac{du}{dy}$$

Where,

τ = Shear stress

μ = Dynamic Viscosity

du/dy = Rate of shear deformation

While the magneto-rheological fluid falls under a class of ferro-fluids in can further be classified into a class of smart fluids whose rheological properties (elasticity, plasticity, or viscosity) change in the presence of a magnetic field. MR fluids are suspensions of soft particles, having a diameter of 1–5 mm, in a special carrier liquid such as water, mineral oil, synthetic oil, and glycol. When an external magnetic field is applied to the fluid, the suspended particles in the fluid form chains and the

suspension becomes like a semi-solid material due to the increase in the apparent viscosity. Only when under a magnetic field, a magneto-rheological fluid behaves like a non-Newtonian fluid with controllable viscosity.

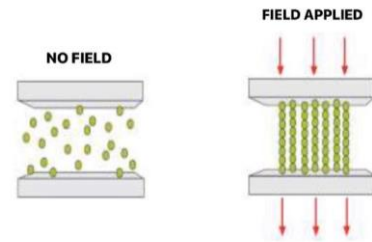

Fig. 2: MR effect

From the Fig. 2 we get a better visual understanding about how the atoms of a magneto-rheological fluid align themselves once in contact with a magnetic field and as a result the viscosity increases.

6. MANUFACTURING OF MAGNETO-RHEOLOGICAL DAMPERS

6.1DESIGN

➤ DESIGN CONSIDERATIONS

Material = C 45 (mild steel)

Take FOS= 2

$$\sigma_t = \sigma_b = 540 / \text{fos} = 270 \text{ N/mm}^2$$

$$\sigma_s = 0.5 \sigma_t$$

$$= 0.5 \times 270$$

$$= 135 \text{ N/mm}^2$$

➤ DESIGN CALCULATIONS

Area x Pressure = Force Output

$$F = P \times A$$

Let us design the cylinder for 100 kg weight = 981 N

$$981 = P \times \pi r^2$$

$$P = 981 / \pi r^2$$

$$P = 8.674 \text{ N/mm}^2.$$

6.1.1. DESIGN OF CYLINDER

For thickness of wall of the cylinder, from Hooke’s law

$$\text{We have, } t = pd/4 \sigma_{\text{tensile}}$$

where

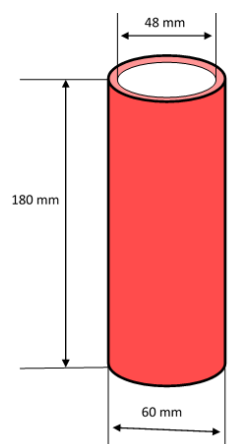

$p = \text{internal pressure} = 8.674 \text{ N/mm}^2$,

$d = \text{diameter of cylinder} = 48 \text{ mm}$ selected, $\sigma_{\text{tensile}} =$ permissible stress.

Considering factor of safety as 4.

We get permissible stress = ultimate stress/factor of safety

$$\sigma_{\text{tensile}} = 135 \text{ N/mm}^2$$

Substituting these value in the thickness formula,

We get, $t = 8.674 \times 48 / 4 \times 135$

$$= 416.352 / 540 = 0.048$$

$$t = 0.77 \text{ mm}$$

But standard available cylinder in the market is 6 mm thick,

So, our design is safe.

Outer Dia. of cylinder = $48 + (2 \times 6) = 60 \text{ mm}$

The minimum outside diameter of cylinder is 60 mm.

6.1.2. DESIGN OF PISTON ROD

Load of 100 kg on piston rod, so it may fail under bending.

$$M = WL/4 = 981 \times 290/4$$

$$= 71122.5 \text{ N-mm}$$

$$Z = \pi(D^4 - d^4) / D \times 32$$

$$= \pi(12^4 - 4^4) / (12 \times 32)$$

$$Z = 167.55 \text{ mm}^3$$

$$\sigma_b (\text{induced}) = M/Z = 71122.5/167.5 = 424.5 \text{ N/mm}^2$$

As induced bending stress is less than allowable bending stress i.e. 655 N/mm^2 .

6.2. CONSTRUCTION

The proper selection of material for different parts of a machine is the main objective in the fabrication of that machine. For a design engineer it is must that he should be familiar with the effect, which the manufacturing process and heat treatment would have on the properties of materials.

Hence the material is chosen while keeping in mind these factors of the material- availability, economical, machinability, strength, yield stress, stiffness, elasticity, plasticity, low thermal conductivity, ductility, brittleness, malleability, toughness, resilience, creep and finally

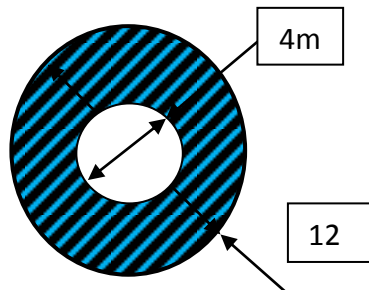

hardness. Where to check hardness of a material several tests can be conducted-

- i. Brinell hardness test.
- ii. Rockwell hardness test.
- iii. Vicker's hardness test.

Hence, the most preferable material would be Mild Steel (MS) as it is readily available in markets and while being cheap it has good mechanical properties, economical to use, high tensile strength, moderate Factor of Safety (FOS), is available in standard sizes and also has a low co-efficient of thermal expansion.

Mild Steel also does possess properties like, having carbon content of from 0.15% to 0.30%, it is easily weldable, both ultimate tensile and compressive strength of these steel increases with increasing the carbon content, they can be easily gas welded or electric or arc welded and therefore these are some of the major reasons to use Mild Steel.

7. METHODOLOGY USED FOR MANUFACTURING MAGNETO-RHEOLOGICAL FLUID-

✚ METHOD AND COMPOSITION-

1. Mix Cast Iron particles (80% by wt.) with oleic acid (0.25% by wt.) for 30 minutes at 400 R.P.M in the stirrer.
2. After that pour white grease (0.25% by wt.) and mix it for 30 minutes at 400 R.P.M in the same stirrer.
3. Then add servo medium e.g. paraffin oil (19.5% by wt.) in small amounts gradually (4% by wt.) after every 30 minutes and mix it for 3 hours at 450 R.P.M in the same stirrer.

There are many other ways to manufacture the magneto-rheological or any other ferro-fluids, the one stated above of one of the type and also it may vary from the industrial grade fluid, as there can be seen an additional substance called surfactant or stabilizer in the industrial grade. This addition of surfactant prevents the sedimentation and separation of the fluids or the fluid-oil and the solid particles- Cast Iron particles.



FIG. 3: THE MANUFACTURED MAGNETO-RHEOLOGICAL FLUID

RHEOLOGICAL FLUID

In order to, initially and partially, test the efficiency of the manufactured magneto-rheological fluid it can be poured into a beaker and a magnet should be brought near it, if the fluid tends to form a spike-like layer upon it indicates that the fluid contains magnetic properties, as shown in the above Fig 3.

8. PROJECT ASSEMBLY



Fig. 4: 3D MODEL ASSEMBLY ON SOLIDWORKS

Here in we have provided a hand lever set-up in order to operate the suspension manual as to feel the amount of damping force required.

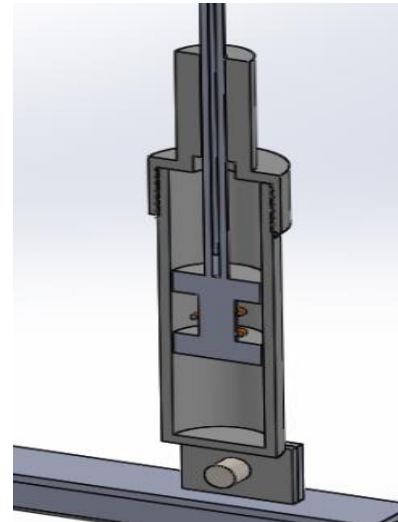

Fig 5: CUT SECTION OF 3D MODEL

9. TESTING OF DAMPER

During all the three experiments mentioned over here amplitude and voltage were kept constant throughout the procedure, i.e. 0.5cm and 6V respectively and the results were plotted over a graph representing the Damping Force-Displacement relationships.

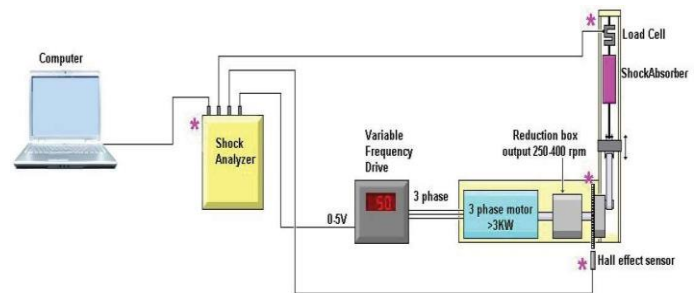
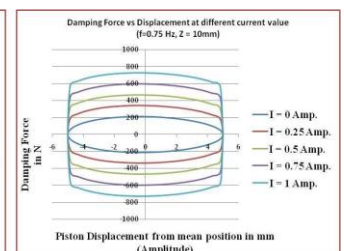
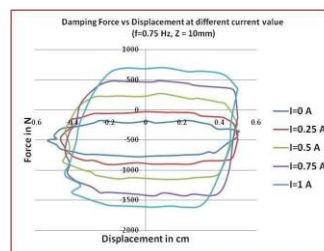

Fig 6: Layout of connections of the testing grid

The results and graphs obtained are only for one complete cycle.

1. Amplitude $A = 0.5$ cm. (Stroke $Z = 1.0$ cm)

Frequency $f = 0.75$ Hz. (Angular speed of crank plate = 45RPM)



MEASURED VALUE

ANALYTICAL VALUE

2. Amplitude $A = 0.5$ cm. (Stroke $Z = 1.0$ cm.)

Frequency $f = 1.0$ Hz. (Angular speed of crank plate = 60 RPM)

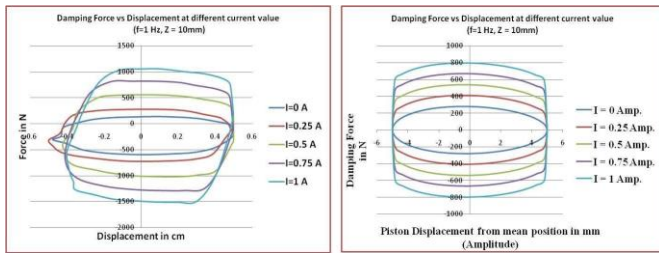

MEASURED VALUE

ANALYTICAL VALUE

3. Amplitude $A = 0.5$ cm. (Stroke $Z = 1.0$ cm.)

Frequency $f = 1.5$ Hz. (Angular speed of crank plate = 90 RPM)

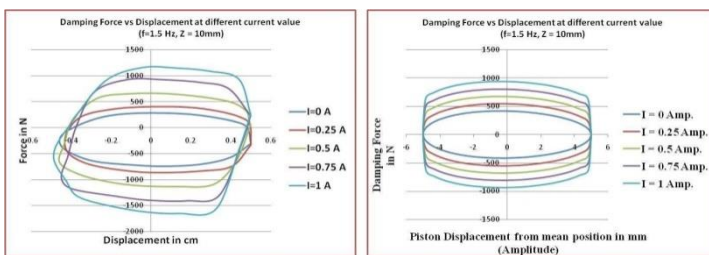

MEASURED VALUE

ANALYTICAL VALUE

10. CONCLUSION

It can be seen in the results above and hence can also be proved that the magento-rheological fluids are such ferro-fluids which consists the property of having varying viscosity which is only affected and in-activated by increasing the voltage or current flow across the circuit.

REFERENCES

1. Deepak Baranwal, Dr. T.S. Deshmukh. MR-Fluid Technology and Its Application- A Review, International Journal of Emerging Technology and Advanced Engineering.

Website: www.ijetae.com (ISSN 2250-2459, ISO 9001:2008 Certified Journal, Volume 2, Issue 12, December 2012)

2. A. Ashfak, A. Saheed, K. K. Abdul Rasheed, and J. Abdul Jaleel, Design, Fabrication and Evaluation of MR DamperWorld Academy of Science, Engineering and Technology- International Journal of Mechanical, Aerospace, Industrial, Mechatronic and Manufacturing Engineering Vol:3, No:5, 2009.

3. Muhammad Aslam, yao Xiong-liang, and Deng Zhong-chao, Review of magnetorheological (MR) fluids and its applications in vibration control- Journal of Marine Science and Application, Vol.5, No.3, September 2006, pp. 17-29.

4. Christopher A. Pare, Experimentation Evaluation of Semiactive magneto-rheological suspensions for passenger vehicles- Thesis submitted to Virginia Polytechnic and State University.

5.P.R. Kale, S.R. Lalalikar, Performance Evaluation Of Quarter Car Semiactive Suspension Model With Skyhook Control Two State MR Damper Using Matlab-Simulink, Paripex- Indian Journal of Research.

6. Mark R Jolly, J David Carlson and Beth Munoz, A model of the behaviour of magneto-rheological fluids, Lord corporation, Thomas Lord Research Center.