

Dual Verification ATM for Blind People

Asmita Raut¹, Rajashree Dahiphale², Rajani Adsule³, Jyoti Kulkarni⁴

^{1,2,3}Student, B.E. Electronics & Telecommunication

⁴Assistant Professor, Dept. of Electronics & Telecommunication, Pimpri Chinchwad College of Engineering, Pune

Abstract - Automated Teller Machine (ATM) provides transaction with more security than other system. It provides more security with provided secured database. This paper presenting a system with feature of dual verification for visually challenged people. In this paper, we are going to focus on Face as well as Speaker recognition algorithm. Hence it provides more security and accessibility with the help of Raspberry. Matching of face and voice is at highest priority amongst all process. After matching is successful, all operations regarding transactions are carried out with the help of voice commands.

Key Words: Dual Verification, Face Recognition, Speaker Identification, Voice Command, Raspberry, Pi Camera

1. INTRODUCTION

The Dual verification of ATM for Blind people is useful for visually challenged people by using voice recognition and face recognition technologies. Automated Teller Machine provides face recognition based authentication before doing any financial transactions.

1.1 Existing System

About 285 million people round the world are visually impaired and about 35 million people are blind. So there should be a system to assist the differently abled ones to access ATM. The system which are used currently are fingerprint based or smartcard authentication. But it becomes difficult for Blind People to use ATM card.

1.2 Proposed System

The concern is to make available ATM for blind people by adding up an additional voice recognition system feature. The process of face recognition involves preprocessing, feature extraction and matching. Matching is done by comparing the user's face with the existing face in database and images which were acquired at the time of opening an account in the bank account. Once the face recognition process of the user passes the authentication procedures of the system, the user is now able to carry out further transactions using voice based commands by speaking through a microphone. This model not only provides security but also accessibility to certain people with visual impairment and eye disabilities. The system also gives alert notification to the blind if any one follows him into the ATM room by detecting other person

entrance using camera. In voice recognition, the system automatically identifies the voice based on the individual information in the speech signals. In voice identification, user provides the given voice input from among a set of known users while voice verification accepts or rejects valid.. In text dependent verification, the input presented to the system is known beforehand while in text independent recognition systems, the system doesn't assume the text spoken, but it models the general acoustic properties of the vocal spectrum of the speaker. In general, the text dependent systems are more reliable and accurate, since both the content and voice can be compared. Frequency, Amplitude, Pitch, and Phonetic emphasis are variables that parameterize human speech; these variables differ from speaker to speaker.

2. System Architecture

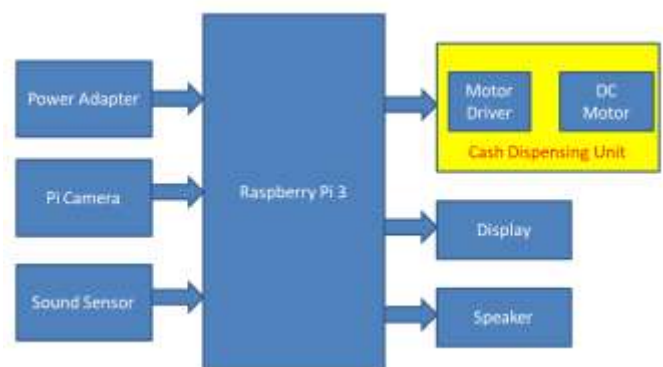

Fig -1: Block Diagram

In this proposed project, our primary aim is to detect the face of single person using image processing. Then we will check for matching voice to that face is coming from sound sensor or not. For this, we need to interface sound sensor to raspberry. Taking a photograph can be done by attaching a camera to a raspberry. Then we will apply image processing to that image using PYTHON to detect and recognize the face. When face and speaker voice matches with each other then next operation will performed according to voice command.

2.1 Hardware Description

2.1.1 Raspberry Pi 3 B+



Fig -2: Raspberry Pi

Microprocessor which has 40 pins with 27 GPIO pins, it's a 1 Giga Bytes of RAM and a SD card slot for the storage or the ROM, it are often used as a mini computer for low computing operations, it's a dual band LAN, faster Ethernet, Bluetooth, it also has USB and HDMI ports for connecting devices. This device are often used as a server which we do during this project.

2.1.2 Pi Camera

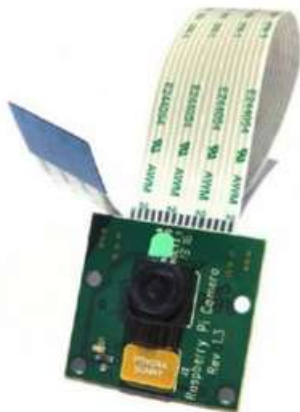

Fig -3: Raspberry Pi Camera

Use the Pi camera to capture still images, live streaming and for video .Raspberry Pi has onboard port facility for camera interfacing. Here we are going to use 5 mega pixel camera.

2.1.3 Sound Sensor

The Sound Sensor can detect the sound strength of the voice., the most component of the module may be a simple microphone and LM393 level convertor chip. The sensor can provide both digital and analog output form. This sensor employs a microphone to supply input to

buffer, peak detector and an amplifier. This sensor identifies a sound, & processes an o/p voltage signal to a microcontroller. Then, it executes required processing.

This sensor is capable to work out noise levels within DB's or decibels at 3 kHz 6 kHz frequencies approximately wherever the human ear is sensitive. In smartphone, there's an android application namely decibel meter wont to measure the sound level.



Fig -4: Sound Sensor

2.1.4 DC motor



Fig -5: DC Motor

Here for cash dispensing purpose we are going to use DC motor. A DC motor is any of a category of rotary electrical motors that converts DC electricity into energy. The foremost common types believe the forces produced by magnetic fields. All DC motors have some internal mechanism, either electromechanical or electronic, to periodically change the direction of current partially of the motor.

2.1.5 Speaker

Speaker is interfaced with processor to speak out the process to inform the blind person about the process execution.

2.2 Flow Chart

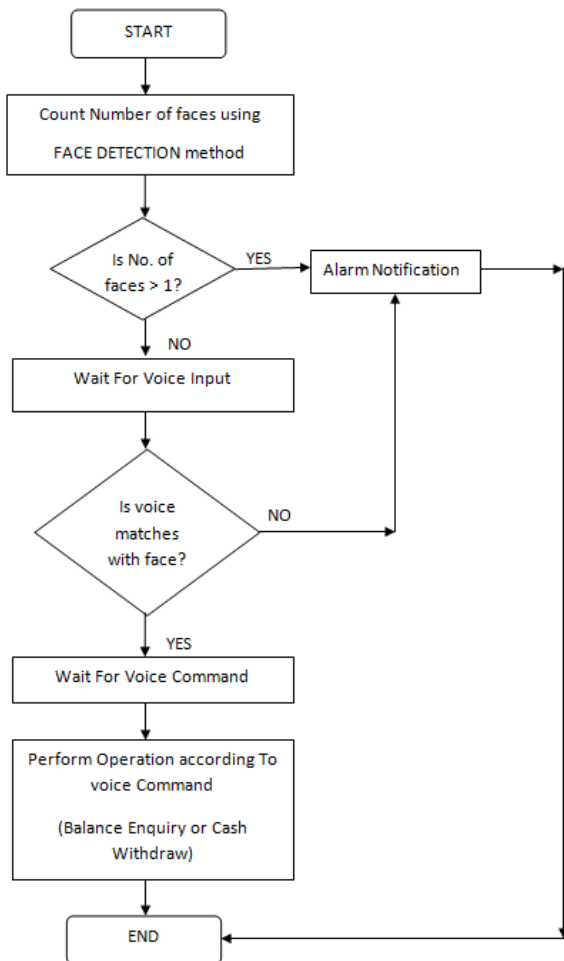

Fig -6: Flow Chart

3. CONCLUSION

Our proposed system enables the dim-sighted people to access the ATM and perform transactions through voice commands. It not only allows a single user at a time but also provides face recognition based authentication.

REFERENCES

1. M. M. E. Raj; Anitha Julian, "Design and implementation of anti-theft ATM machine using embedded systems", IEEE 2015
2. R. Singh, B. Raj, and R. M. Stern, "Automatic generation of sub word units for speech recognition systems," IEEE Trans. Speech Audio Processing, vol. 10, no. 2, Feb. 2002.
3. F. K. Song, A. E. Rosenberg, and B. H. Juang, "A vector quantization approach to speaker recognition," 2007

4. Yekini N.A, Iteboje A.O, Oyeyinka I.K Akinwole A.K. "Automated Biometric Voice-Based Access Control in Automatic Teller Machine (ATM)" 2012
5. Jignesh J. Patoliya ; Miral M. Desai. "Face detection based ATM security system using embedded Linux platform", 2017 2nd International Conference for Convergence in Technology (I2CT)
6. D. Narmada ; J. V Priyadarsini, "Design and implementation of security based ATM using ARM11", 2016 International Conference on Inventive Computation Technologies (ICICT)