

# AUTOMATIC TOLLGATE CONTROL SYSTEM USING MICROCONTROLLER AND RFID

Mr. S. GokulaKrishan<sup>1</sup> N. Indumathi<sup>2</sup> M. Charitha<sup>3</sup> M. Sai kiran<sup>4</sup> M. Himadhar Reddy<sup>5</sup>

<sup>1</sup>Assistant Professor, Department of Computer Science and Engineering, SCSVMV, Kanchipuram, India

<sup>2,3,4,5</sup> UG Scholar, Department of Computer Science and Engineering, SCSVMV, Kanchipuram, India

\*\*\*

**ABSTRACT:** In this project, The RFID tag is used as a unique identity for account of a particular user. First, the user is prompted to scan his tag. The serial code of the tag is identified by the reader module and is sent to ATmega162 for comparison with the stored data. If the identity is matched with the one already stored in the system, the toll amount is deducted from his account and user gets to drive through the plaza. On the contrary, if the tag is not identified 'INVALID' is displayed on the LCD screen. If the balance in the user's account is low 'PLEASE RECHARGE' is displayed on LCD screen and the user needs to recharge the RFID card. The purpose of GSM is to alert the user by sending a text message to his personal mobile. If there is low balance in the RFID tag it will alert the user to recharge. If the balance is deducted it will send the balance to the users mobile.

**Keywords:** RFID reader, Micro controller, Proximity Sensors, LCD, Gate Open, Auto Payment

## I. INTRODUCTION

### A. Microcontroller

Microcontroller can be termed as a single on chip computer which includes number of peripherals like RAM, EEPROM, Timers etc., required to perform some predefined task. The computer on one hand is designed to perform all the general purpose tasks on a single machine like you can use a computer to run a software to perform calculations, to store some multimedia file, to access internet through the browser. Whereas the microcontrollers are meant to perform only the specific tasks, for e.g., switching the AC off automatically when room temperature drops to a certain defined limit and again turning it ON when temperature rises above the defined limit. There are number of popular families of microcontrollers which are used in different applications as per their capability and feasibility to perform the desired task, most common of these are 8051, AVR and PIC microcontrollers. AVR was developed in the year 1996 by Atmel Corporation. The architecture of AVR was developed by Alif Egil, Bogen Vegard, Wollan RISC microcontroller, also known as Advanced Virtual RISC. The AT90S8515 was the first microcontroller which was based on AVR architecture. However, the first microcontroller to hit the commercial market was AT90S1200 in the year 1997. The device is manufactured using Atmel's high density non-volatile memory technology. The On-chip ISP Flash allows the program memory to be reprogrammed In-System through an SPI

serial interface, by conventional non-volatile memory programmer, or by an On-chip Boot Program running on the AVR core. The Boot Program can use any interface to download the Application Program in the Application Flash memory. Software in the Boot Flash section will continue to run while the Application Flash section is updated, providing true Read-While-Write operation.

### B. RFID

Radio-Frequency Identification (RFID) is an automatic identification method, relying on storing and remotely retrieving data using devices called RFID tags or Transponder s. This project focuses on an Electronic Toll Collection (ETC) system using Radio frequency identification (RFID) technology. The RFID system uses tags, through which information embedded on the tags are read by RFID readers. The proposed system eliminates the need for motorists and toll authorities to manually perform ticket payments and toll fee collections, respectively. The technology requires some extent of cooperation of an RFID reader and an RFID tag. An RFID tag is an object that can be applied to or incorporated into a product, animal, or person for the purpose of identification and tracking using radio waves. Some tags can be read from several meters away and beyond the line of sight of the reader. The Purpose of Radio frequency Identification and Detection system is to facilitate data transmission through the portable device known as tag that is read with the help of RFID reader; and process it as per the needs of an application. The early 20th century saw the beginning of modern radio communication. The convergence of radar with the ability to broadcast radio led to the idea for Radio Frequency Identification. Even though one of the first papers exploring RFID was written in 1948, it would take the development of other technologies before RFID could become practical. One of the first commercial was Electronic Article Surveillance (EAS) as a way to curtail theft. The possibility of using RFID as a tracking device led many companies to build systems for this purpose. The desire by highway transportation authorities to see traffic move quicker through toll booths saw the invention of electronic toll collection systems and the need to limited access to certain areas also drove the development of RFID.

Automation of Toll Gate and Vehicle Tracking System is designed to automatically keep track of the vehicle's movement, record the time and the details like Owner's name, contact details, vehicle registration number,

vehicle model etc. A computerized system automatically identifies an approaching vehicle and records the vehicle details. RFID-based automation of Toll gate and vehicle tracking system is designed to automatically process the toll gate system without any manual power. This system is very useful for automatic bomb detection, vehicle monitoring, time management and also for automation of payment system. In this paper, we propose an automatic system of toll gate for monitoring and controlling the entry of vehicle. This RFID-based system automatically records time and the details of vehicle's entry time, owner's name, mobile number and vehicle model etc. A passive RFID tag is used to have information about the vehicle registration number etc. And also read by RFID reader which is located at computerized system. ATCS is an Automated Toll Collection System used for collecting tax automatically. In this we do the identification with the help of radio frequency. A vehicle will hold an RFID tag. This tag is nothing but unique identification number assigned. This will be assigned by RTO or traffic governing authority. In accordance with this number we will store, all basic information as well as the amount he has paid in advance for the TOLL collection. Reader will be strategically placed at toll collection center. Whenever the vehicle passes the toll naka, the tax amount will be deducted from his prepaid balance. New balance will be updated. In case if one has insufficient balance, his updated balance will be negative one. ATCS is an Automated Toll Collection System used for collecting tax automatically. RFID cards simulate a credit card in a capacity and pattern, the tag usually contains an embedded microprocessor. Normally the Intelligent control system does not allow the unauthorized entry of any person into the control areas. If suppose the illegal entry through gate is observed, then it will be registered and providing the warning sound. Each vehicle will hold an RFID tag and its contains unique identification number assigned. The assigning process will be done by RTO or traffic governing authority And the Reader will be strategically placed at toll collection center. Whenever the vehicle passes the toll booth, the tax amount will be deducted from his prepaid balance. New balance will be updated. In case if one has insufficient balance, his updated balance will be negative one. To tackle this problem, we are alarming a sound, which will alert the authority that this vehicle doesn't have sufficient balance and that particular vehicle can be trapped. As vehicles don't have to stop in a queue, it assures time saving, fuel conservation and also contributing in saving of money. The conventional or the traditional way of collecting the toll from the vehicle owners or the drivers is to stop the car by the toll gate stations and then pay the amount to the toll collector in the toll booth, after which the gate is opened either mechanically or electronically for the driver to get through the toll station. So in order to stop all these problems and inconvenience, we introduce an automated way of collecting the toll and traffic management. It is called Electronic Toll Gate Stations using RFID Technology. Automatized toll gate system using Radio Frequency Identification emerges as a

converging technology where time and efficiency are the matter of priority in toll collection systems of present day. In order to overcome the major issue of collision, in our project the reader is placed on the road, and the tag is placed beneath the vehicle. The object detection sensor which is placed on the side of the road detects the approach of the oncoming vehicle. Thus the reader reads the information in the tag and the transaction takes place through a centralized data base and the aftermath details of the transaction is intimated to the user's mobile through GSM technology. ATSRT is an Automatic Tolling System using RFID

Technology is used for collecting tax automatically. In this we do the identification with the help of radio frequency. A vehicle will hold an RFID tag. This tag is nothing but unique identification number assigned. This will be assigned by RTO or traffic governing authority. In accordance with this number we will store, all basic information as well as the amount he has paid in advance for the TOLL collection. Reader will be strategically placed at toll collection center. Whenever the vehicle passes the toll booth, the tax amount will be deducted from his prepaid balance. New balance will be updated. In case if one has insufficient balance, he will have to pay the tax in cash. Automatic Toll Tax systems have really helped a lot in reducing the heavy congestion caused in the metropolitan cities of today. It is one of the easiest methods used to organize the heavy flow of traffic. When the car moves through the toll gate on any road, it is indicated on the RFID reader that it has crossed the clearing. The need for manual toll based systems is completely reduced in this methods and the tolling system works through RFID. The system thus installed is quite expedient reducing the time and cost of travelers since the tag can be deciphered from a distance.

## II. SYSTEM DESIGN

The microcontroller first initializes and checks all the components. Then 'SHOW YOUR CARD' is displayed on the screen. Once this message is displayed we can place the card on the reader. Once the card is sensed it will check for validity. If, the card is valid then it will detect the balance and once the vehicle passes the proximity sensor1 the gate opens, once the vehicle passes through proximity sensor 2 the gate closes automatically. If, the card is found invalid an alert is sent to the toll authority with the details of the card and 'INVALID' is displayed. If, there is low balance in the card then an alert message is sent 'INSUFFICIENT FUND PLEASE RECHARGE YOUR CARD' the person needs to recharge the card at the tollbooth or need to use the paid tollgate. Each and every entry and exit of the vehicle is stored in the Database which will be useful in tracking of the Vehicle.

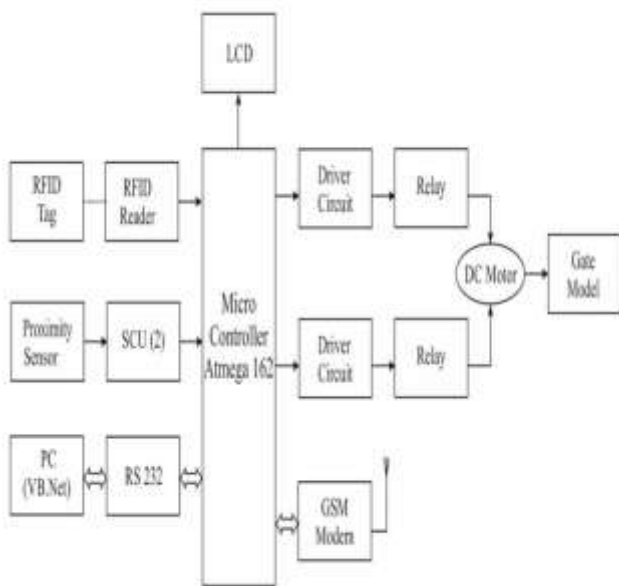

Fig 1 Block diagram

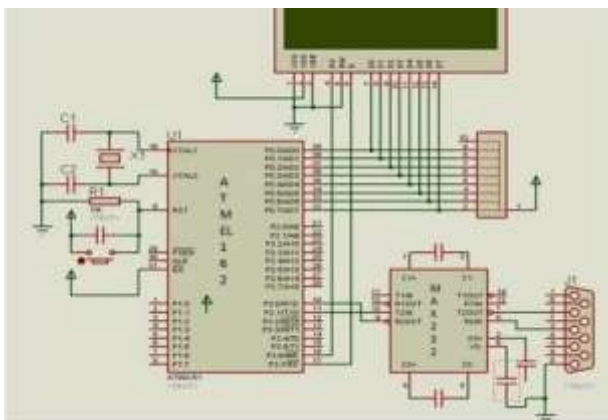

Fig 2 Circuit Diagram

### III. COMPONENTS DESCRIPTION

1. RFID card: RFID cards have diverse range of functions, while provides convenience, as the cards must simply be waived or tapped in front of a reader rather than swiped. These cards are used for applications as access control in security systems, time and attendance, network login security, biometric verification, cashless payment, and event management.



Fig 3 RFID cards

2. RFID reader: An RFID reader is a device that is used to interrogate an RFID tag. The reader has an inbuilt antenna that emits radio waves; the tag responds by sends back its data.



Fig 4 RFID reader

3. Micro controller: Micro controller senses the signal given from switches and decides the mode of operation i.e. recharge mode or toll collection mode. It fetches data from memory location and sends it to output devices like display, motor driver and buzzer.



Fig 5 Micro Controller

4. Liquid Crystal display: It consists of Liquid Crystal display (LCD). The display is various messages like valid card, invalid card, access allowed, manual access etc. We are going to use 16x2 alphanumeric displays.



Fig 6 Liquid Crystal display

5. Motor Driver: Microcontroller output is 5 volts and DC motor requires 12 volts supply. Motor driver IC is used to convert 5v to 12v, which is required to drive the motor.

6. DC Motor: DC Motor is used to open the Gate barrier. This will be done when user has successfully performed the RFID swap operation with sufficient balance.



Fig 7 DC Motor

7. Proximity Sensor: Inductive proximity sensors generate an electromagnetic field and detect the eddy current losses induced when the metal target enters the field.



Fig 8 Proximity Sensor

8. GSM Module: GSM Module alerts the user about their balance deduction from his/her account.



Fig 9 GSM Module

#### IV. METHODOLOGY

This module gives idea about creating using roadside-unit for processing the signal from the RFID tag. Once the System has been implemented completely then next task is to observe how system is supposed to operate to carry out different operations involved in System. When vehicle will cross the sensor which are fixed at some meter distance from processing unit, Tag will read by RFID Reader. Sensor may fixed vertically at both sides or at the center of road depend upon where the TAG is mounted on vehicle. TAG contains unique identification number. Then data read by the RFID reader will be taken by Microcontroller Which will process the data for authentication of authorized user. If valid user, then data will send to processing unit which then check the respective account of that user from database to ensure weather user have sufficient amount for toll payment or not. If amount is not sufficient to pay toll, then user must have to recharge its account by paying manually. If sufficient amount, then user is allow to pass by iron bar which will rise up with the help mechanical assembly after receiving the permission signal from processing unit. If user is not valid then iron bar will remain down and appropriate action will be taken against invalid user.

#### V. ALGORITHM

**Case 1:** Check Weather the vehicle is detected. If, detected Check for validity. If the Vehicle is Valid then Detect the amount from the account and alert the user by Sending sms to his /her mobile Number. The gate will open once the user crosses the proximity sensor1, once the vehicle passes through the proximity sensor 2, the gate closes automatically.

**Case 2:** If the card is Invalid then an alert is given to the toll authority with the details of the card.

**Case 3:** Check Weather the vehicle is detected. If, detected Check for validity. If the Vehicle is Valid then it checks for sufficient balance. If the balance is sufficient then it follows case 1 procedure. If the balance is insufficient then recharge alert is sent to the user 'INSUFFICIENT FUND PLEASE RECHARGE YOUR CARD'. Then the user needs to recharge the card at the tollbooth and continue his/her journey.

#### VI. RESULTS AND VIEWS

We had introduced the automatic toll gate system controlled by ATMEL microcontroller. It is a 40 pin IC which having the property of burning a program while running another program. It is reliable, flexible and of low cost. By practically implementing 'Automatic Toll Gate Control System using Microcontroller and RFID' we can provide a convenient transportation for the public i.e. we can avoid traffic congestion. It is the most efficient way of toll collection which can reduce the manual effort at toll plaza. We are avoiding the emergency vehicles such as ambulance, fire force etc. from the toll collection.

In this busy world we give preference for time and efficiency, so for fulfilling this we can implement this kind of toll collection system

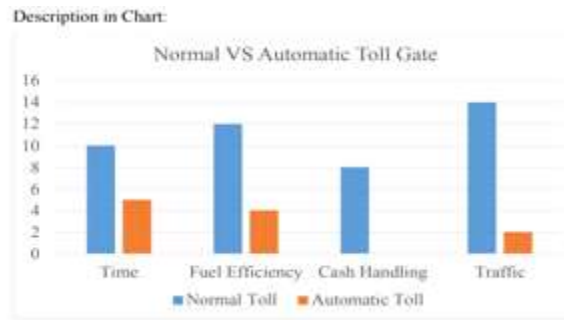

Fig 10 Description in Chart

	Normal Toll	Automatic Toll
Time	10	5
Fuel Efficiency	12	4
Cash Handling	8	0
Traffic	14	2

Fig 11 Description Table

## VII. CONCLUSION

The automatic toll gate system reduces man power and cost. It is more automated and convenient way of collecting the toll and traffic management and it is also providing vehicle access security. Using RFID wireless communication, we now knew that the vehicle is sensed at the toll gate by the vehicle tag id and the amount is realized to be automatically debited from the user account. By using this traffic at the tollgates can be avoided and the users can pass the toll gates without stopping for a long time.

## VIII. REFERENCES

- RFID based toll collection system 2011 IEEE third international Conference
- ActiveWaveInc. <http://www.activewaveinc.com>
- Smart key Access Control System <http://www.smartkeyrfid.com>
- D. M. Grimes and T. O. Jones, –Automotive radar: A brief review, Proc. IEEE, vol. 62, no. 6, pp. 804–822, Jun. 1974.
- D. M. Grimes and T. O. Jones, –Automotive radar: A brief review, Proc. IEEE, vol. 62, no. 6, pp. 804–822, Jun. 1974.
- Liu Bin, Lu Xiaobo and Gao Chaohui. –Comparing and testing of ETC modes in Chinese freeway. || Journal of Transportation Engineering and Information, 5(2), 2007, pp.31-35.
- A Novel Chipless RFID System Based on Planar Multiresonators for Barcode Replacement Stevan Preradovic, Isaac Balbin, Nemaï C. Karmakar and Gerry Swiegers2008
- Wayne Wolf. Computers as Components Principles of Embedded Computing System Design [M], Beijing: Publishing House of Machinery Industry. 2002
- WARWICK A. SMITH, ARM Microcontroller Interfacing: HARDWARE AND SOFTWARE., elector International Media BV 2010
- JOHN B. PEATMAN, Embedded Design with the PIC18F452 Microcontroller, Prentice Hall; 1 edition (5 August 2002)
- C.M. Roberts, Radio frequency identification (RF434) Computers & Security, Vol. 25, Issue 1, February 2006, Pages 18-26.
- Moratuwa, RF434-based anti-theft auto security system with an immobilizer, Industrial and Information Systems, 2007. ICIIS 2007 International Conference. Pages 441-446
- M. Deriche, M. Mohandes “A Hybrid RFID-LPR System for Vehicle Access Control during Pilgrimage Season in Saudi Arabia”, International Multi- Conference on Systems, Signals and Devices 2012.

14. Elipe.NageswaraRao, G.Tirumala Vasu, N.G.N.Prasad, kranthi Kumar, V.Rajesh, "Payment Automation at Toll-Gate Using RFID and SMS Alert", IJCET Vol.2, SP-1, Dec.2011.
15. Janani Krishnamurthy, Nitin Mohan, Rajeshwari Hegde, "Automation of Toll Gate and Vehicle Tracking", International Conference on Computer Science and Information Technology 2008.
16. Kenneth Jayala, "8051 Microcontroller Architecture", programming and application.
17. Muhammad Ali Mazidi, Janice Gillispie Mazidi "The 8051 Microcontroller and Embedded Systems", Pearson Education.
18. Teruaki Ito, "Process Simulation Approach To
19. Design And Evaluation Of Toll Plaza With ETC Gates".
20. Yanbo Wu, Quan Z. Sheng, "Modeling Object Flows from Distributed and Federated RFID Data Streams for Efficient Tracking and Tracing". [20] RFID Technology [Online] Available: <http://www.answers.com/topic/radio-frequency-identification>. [21] Radio Frequency Identification (RFID) RFID [Online] Available:
21. <http://www.rfidjournal.com/apparel2006/index.php>.
22. RFID Handbook, <http://rfid-handbook.com>.