

# Radius Approach for Inverse Kinematics of 4-R Manipulator in Spatial Plane

Naisarg J. Pandya<sup>1</sup>, Chanakya K. Thaker<sup>2</sup>

<sup>1,2</sup>Department of Mechanical Engineering, LDRP-ITR Gandhinagar, Gujarat, india.

\*\*\*

**Abstract:** In this paper, we present new approach for inverse kinematics of 4-R manipulator in spatial plane. Generally the conventional method D-H algorithm is used for inverse kinematics which uses matrix transformation and this approach involve computational complexity. For more than 2-R manipulator it will become more complex, so for more no of link we represent easy solution of inverse kinematics of 4-R manipulator. This approach will make faster computation over the conventional methods to find inverse kinematics solution by using several geometric relations and constrain for reduce computation complexity. Main objective for reduce computation is to reduce response time of electronic system and it will make faster operation to reach the required location

**Key Words-** Manipulator, R-(revolute joint), Working envelop, DOF, Spatial plane.

## 1. INTRODUCTION

A Manipulator is an assembly of segments and joints that can be conveniently divided into three sections: the arm, consisting of one or more segments and joints; the wrist, usually consisting of one to three segments and joints; and a gripper or other means of attaching or grasping. Some texts on the subject divide manipulators into only two sections, arm and gripper. It consists of a fixed base, a series of links connected by joints, and ending at a free end carrying the tool or the end-effector. In contrast to parallel manipulators, there are no closed loops. By actuating the joints, one can position and orient the end-effector in a plane or in three-dimensional (3D) space to perform desired tasks with the end-effector. There are mainly four types of joints that are found in robot manipulators: (1) Revolute, rotary or pin joint (R), (2) Prismatic or sliding joint (P), (3) Spherical or ball joint (S), (4) Helical or screw joint (H). Here, 4R represent four numbers of revolute joint used in manipulator. The revolute joint allows a rotation between the two

connecting links. The best example of this is the hinge used to attach a door to the frame. Motion of considered manipulator is in three dimensional space which is called spatial plane. Considered manipulator has four degree of freedom.

In forward kinematics joint parameter are known and end-effector's position can be define by mathematical relation. In inverse kinematic the location co-ordinate are known and joint parameters has to be define ,But it has multiple solution more than one set of joint parameters can be solution for location of co-ordinate so solution should be optimize but optimization make complex computation and make difficult programming for electronics system and it will make more response time for electronic system so researcher find several approach like complex numerical approach, jacobian based transpose method, geometrical approach, cyclic co-ordinate method etc for reduce computation and making faster response of the electronic system which contain mathematical model of inverse kinematics.

For this paper we have reviewed some research paper which mentioned in next page with reference. In third part of paper we have mentioned defining parameters, forward kinematic model and inverse kinematic model for manipulator.

## 2. LITERATURE REVIEW

[1] In 1955, Jacques Denavit and Richard Hartenberg introduced a convention for the definition of the joint matrices [Z] and link matrices [X] to standardize the coordinate frame for spatial linkages. This convention positions the joint frame so that it consists of a screw displacement along the Z-axis and it positions the link frame so it consists of a screw displacement along the X-axis.

[2] Lukas Barnika and Roman Berka presented several ways to solve inverse kinematics problems which include the Jacobian inversion method, optimization based method and cyclic coordinate method (CCD), Genetic programming and the Jacobian based transpose method stating the advantages and disadvantages of each one of them. It also discusses the complexity of these methods due to the matrix operations involved in them.

[3] Liu and Wang highlighted the complex numerical methods involved in finding solutions to inverse kinematics for a robotic system. They also proposed a geometric approach which can reduce the complexity involved in the computational task.

[4] Alexandre N. Pechev proposed a novel way of finding a solution to inverse kinematics without performing the operation of matrix inversion using feedback inverse kinematics method (or FIK) based on the feedback mechanism of a closed-loop system to find results to inverse kinematics problem. This method does not require matrix manipulations and hence reduces computational time.

### 3. PROPOSED METHOD

#### 3.1 Defining parameters

1. Degrees of freedom – this is usually the same as the number of axes.
2. Working envelope – the region of space a robot can reach. Considered manipulator has spherical working envelope.
3. Number of axes – two axes is required to reach any point in a plane; three axes are required to reach any point in space. To fully control the orientation of the end of the arm (i.e. the wrist) three more axes (yaw, pitch, and roll) are required. Some designs (e.g. the SCARA robot) trade limitations in motion possibilities for cost, speed, and accuracy.

#### 3.2 Forward kinematic model

Forward kinematics refers to the use of the kinematics equations of a robot to compute the position of the end-effector from specified values for the joint

parameters. The kinematics equations of the robot are used in robotics, computer games, and animation.

Known data:-  $l_1, \theta_1, l_2, \theta_2, l_3, \theta_3, \theta_4$

Result:-  $x, y, z$

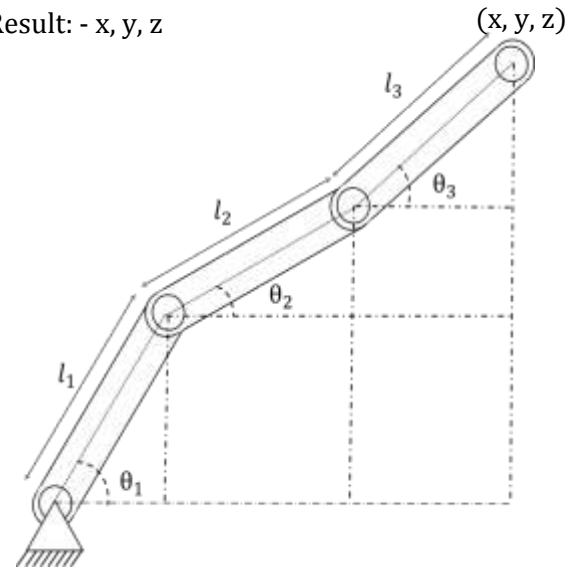

Figure1:- Forward kinematics of 4-R manipulator

$$x = (l_1 \cos \theta_1 + l_2 \cos \theta_2 + l_3 \cos \theta_3) \cos \theta_4$$

$$y = l_1 \sin \theta_1 + l_2 \sin \theta_2 + l_3 \sin \theta_3$$

$$z = (l_1 \cos \theta_1 + l_2 \cos \theta_2 + l_3 \cos \theta_3) \sin \theta_4$$

#### 3.3 Inverse kinematic model

The reverse process that computes the joint parameters that achieve a specified position of the end-effector is known as inverse kinematics. Inverse kinematics is the mathematical process of calculating the variable joint parameters needed to place the end of a kinematic chain, such as a robot manipulator or animation character's skeleton, in a given position and orientation relative to the start of the chain.

This approach first we calculate radius of output point which is R as shown in figure 2. Diagonal distance has to be define for reduce complexity of calculation so. It defines by linear relation & other angular position of each link will be calculated as per mathematical model for particular output. By following the result of mathematical modal end effector will reach the output point.

Known data:-  $l_1, l_2, l_3, x, y, z$

Result :-  $\theta_1, \theta_2, \theta_3, \theta_4$

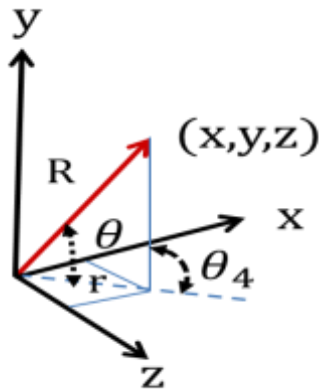

Figure 2: Output point location

$$x^2 + y^2 + z^2 = R^2$$

$$r = \sqrt{x^2 + z^2}$$

$$R \cos \theta = r$$

$$\theta = \cos^{-1} \left( \frac{r}{R} \right)$$

$$l_1 = l_2 = l_3 = l$$

In this method we using linear relation between diagonal D and radius of output point and it will reduce the complexity of mathematical computation. This linear relation consider following two boundary condition in such way there are no singular region in work envelope.

1. For minimum radius (R=0) we consider diagonal D=l so, each revolute make an equal relative angle=60°
2. For maximum radius (R=3l) the diagonal D=2l

$$D = l + \left( \frac{1}{3} \right) R$$

After finding liner relation, radius R and D is known so, by using geometrical relation find some angular parameter which helps to find the output of mathematical model.

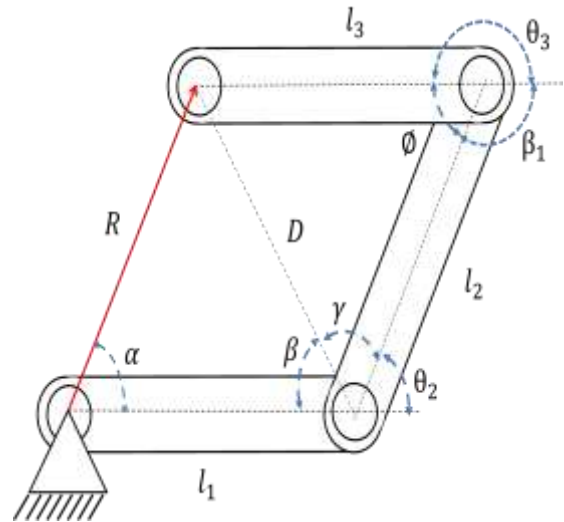

Figure 3: 2D View for defining geometry

From geometry, triangle formed by RDl1 line

$$\alpha = \cos^{-1} \left\{ \frac{R^2 + l^2 - D^2}{2Rl} \right\}$$

$$\beta = \cos^{-1} \left\{ \frac{D^2 + l^2 - R^2}{2Rl} \right\}$$

Consider, triangle formed by l2l3D line

$$\gamma = \cos^{-1} \left\{ \frac{D}{2l} \right\}$$

$$\Phi = \cos^{-1} \left\{ \frac{2l^2 - D^2}{2l^2} \right\}$$

$$\therefore \beta_1 = 180 - \theta_2$$

### 3.4 Result of mathematical modeling

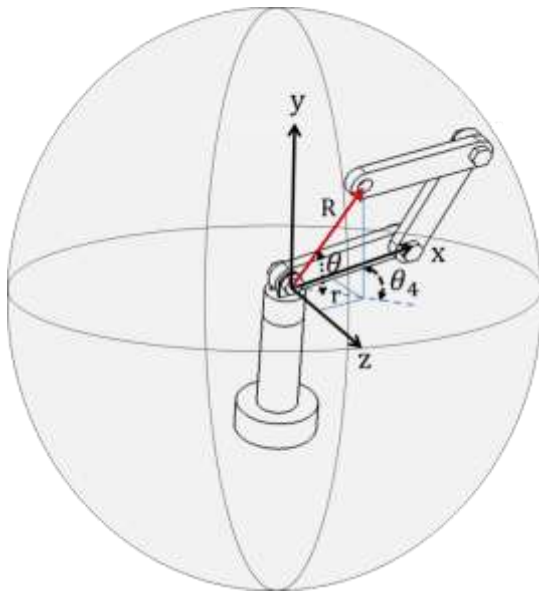

Figure 4:- 3D View of considered manipulator at desired position

$$\theta_1 = \theta - \alpha$$

$$\theta_2 = 180 - (\beta + \alpha)$$

$$\theta_3 = 360 - (\beta_1 + \Phi)$$

$$\theta_4 = \tan^{-1} \left( \frac{z}{x} \right)$$

### 4. CONCLUSION

In concluding statements it can be claimed that this new method is successful and exhibits expected result this model which also results in saving time. We have compared the analyzed result obtained from graphical experimental considering variations further modification suggested is true and considering the probable implementation plays the project could do wonders. The problem statement thus put forward was solved and work successful convenient out.

### 5. FUTURE SCOPE

This approach can be extend for more no of link and it will reduce complexity of mathematical modeling by develop linear relation between diagonals and radius of output point and less complexity of mathematical model will make fast response of electronic system and reduce complexity programming of microcontroller.

### REFERENCES

- [1] Hartenberg, R. S., and J. Denavit. Kinematic Synthesis of Linkages. New York: McGraw-Hill, 1964 on-line through KMODDL
- [2] L. Barinka, Ing. Roman Berka" Inverse Kinematics – Basic Methods" <http://old.cescg.org/CESCG-2002/LBarinka/paper.pdf>
- [3] "Y. Liu, D. Wang" Geometric Approach for Inverse Kinematics Analysis of 6-Dof Serial Robot" International Conference on Information and Automation Lijiang, China, August2015.
- [4] Alexandre N. Pechev, Inverse Kinematics without Matrix Inversion ,IEEE 2008 International Conference on Robotics and Automation