

Automatic Solar Panel Monitoring and Cleaning System

Vaibhavi S. Paste¹, Prachi R. Patil², Akshata R. Sawant³, Ajay M. Pol⁴

^{1,2,3}Student B.E. (Final Year), E&TC Department, KIT's College of Engineering, Kolhapur, Maharashtra, India

⁴Professor, Dept. of E&TC Engineering, KIT's college of Engineering, Kolhapur, Maharashtra, India

Abstract - Sun emits an energy at extremely large rate and if all solar energy could be converted into usable forms, it would be more enough to supply the world's energy demand. And hence the range of solar energy is increased on a large scale. So the Photovoltaic panel production has increased globally in response to the growing demand for solar energy. This has become a solution for environmental degradation due to fossil fuels. But the generation of energy is affected mostly by the dust and debris. And reduces the power by a large value. . There is an urgency in improving the efficiency of solar power generation. Current solar panels setups take a major power loss when unwanted obstructions cover the surface of the panels. The obstruction turns the shaded cell into a resistor, causing it to heat up and consume extra power .To address this issue, we have successfully developed a self-cleaning system for solar panel. The system is designed so as to avoid the wastage of water and to reduce the human effort to clean solar modules, but also labor-intensive, method of sending human workers to hose and wipe down panels manually. The system will help to clean the system when the power goes below certain level and keeps the system clean and also it will overcome all the problems arise.

Key Words: Solar Panel, WiFi Module, Photovoltaic Panels(PV), sprinkler, brushes, PCB, etc.

1. INTRODUCTION

Energy is one of the major issues that the world is facing, the supply of energy has been one of the major problems for both urban and rural households. Solar energy is the basic source for all the sources of energy. Solar power has become a source of renewable energy and solar energy application should be enhanced. The solar panel works, when sunlight directly falls on surface of solar panel. Amount of sunlight falls on the solar panel is directly proportional to the solar energy generated. More is the sunlight falling onto solar panel more is the energy generated by the panel. But the efficiency of the solar panel is highly affected by the amount of dust accumulated on it. It is also affected by the environmental factors like dust, snow, bird droppings etc and they blocks the incident light on the panel. The power output reduces as much as by 50% if the module is not cleaned for a month. This is a big challenge; so it is necessary to clean the solar panel in order to protect and get more power output. So we have designed and developed the automatic solar panel monitoring and cleaning system which will clean the solar panel and improve the panel efficiency & thus reducing the human effort. This low cost solutions very useful in the area of non conventional energy.

2. Literature Survey

Many research studied the effect of dust and other impurities on the solar panel and much experiments have been carried out to clear up this troubles. Under are a few theories and researches which can be related to this mission.

Table -1:

| Sr. No. | Researcher / Author | Topic |
|---------|-----------------------------------|--|
| 1. | Hottel and Woertz | First studied the dust affection sun panel. |
| 2. | Ali Omar Mohamed, Abdulazez Hasan | Developed a framework of weekly cleaning on PV modules |
| 3. | Mark N. Horenstein | Supplied EDS for automated and unceasing removal of dirt without water or shifting elements. |
| 4. | R.Sharma, C.A.Wyatt | obtained an electro-dynamic display |
| 5. | Chandima gomes | Supplied a small experimental set up to smooth the sun strength. |
| 6. | S. B. Halbhavi | Added an automated cleansing device |

3. GEOLOGICAL SURVEY

3.1 Environmental factors affecting efficiency of PV panels

- 1) Shadow: The way solar is designed even a little shade on one panel can shut down solar production on all the other panels. Solar cells are connected in series, and will operate at the current level of the weakest cell, if one solar cell is shaded it will adversely influence the output of all other cells. When deciding on a location for your solar panels do a shading analysis, make sure no shadows will fall on the solar panel array during peak sunlight hours.
- 2) Snow: Once the snow completely blocks out the sun radiation, the PV panels will stop generating electricity .Further, if one area of a solar panel is completely covered by snow, the rest of the panel can stop

functioning because of the way the solar cells are wired together.

- 3) External high temperature: When panels reach high temperatures, power efficiency drops. The efficiency of energy output drops by 1.1% for every extra degree in Celsius once the PV panel temperature reaches 42. There are a couple of ways to deal with high temperature. Install solar panels on a mounting system a few inches off the roof, this will help cool them by allowing air circulation.
- 4) Dust, dirt, bird droppings, pollen and sea salt: Pollen from flowering trees, bird droppings and salt spray from the sea are particular problems for the accumulation of dust. The efficiency of the solar panel can be reduced by up to 50% in a dusty environment.

3.2 Methods to clean solar panel

Various technologies being developed around the world for self-cleaning of solar panels are discussed below:

- 1) Natural removal of dust: The natural powers are employed to remove the dusts, such as wind power, gravitation and the scour of the rainwater. The effect of this method is not very well. It is seen that the solar cell array can be turned to vertical or oblique position to remove the dusts easily when early morning, late evening, night and a rainy day. However, the rotation of the large solar cell array is very difficult.
- 2) Removal of dust using Mechanical Methods: Mechanical methods used for cleaning solar panel are mechanical vibration, ultrasonic cleaning, scrubbing and mopping. Brushing methods is not that efficient because of the sticky nature and small size of dust particles. The process of blowing air on the surface of solar panel is an effective method but it has some negative features. Mechanical methods also includes ultrasonic and the vibrating methods. Main factors in this are driving methodologies, amplitude and frequency of vibration.
- 3) Removal of dust using Electro-Static Methods: If there are a high potential on the surface of the solar panels, the charged and uncharged dusts will be attracted to the panels because of the electrostatic forces. Then, the dust particles will be charged by the solar panels finally, so they have the same electric charge and the electrostatic forces between them are repulsion. At last, the dust particles will float away the solar panels. However, this strategy cannot be used in PV system, because of the effecting of the rain on earth.
- 4) The Sun Brush robot: The structure of the Sun Brush is simple. It is fixed to the roof and is composed of a brush that is driven by a small motor through a roller. The main use was in solar heating systems. Use of this system has led to a 15-18% increase in solar panel efficiency and up to a 20% increase in hot water production.

3. PROPOSED SYSTEM

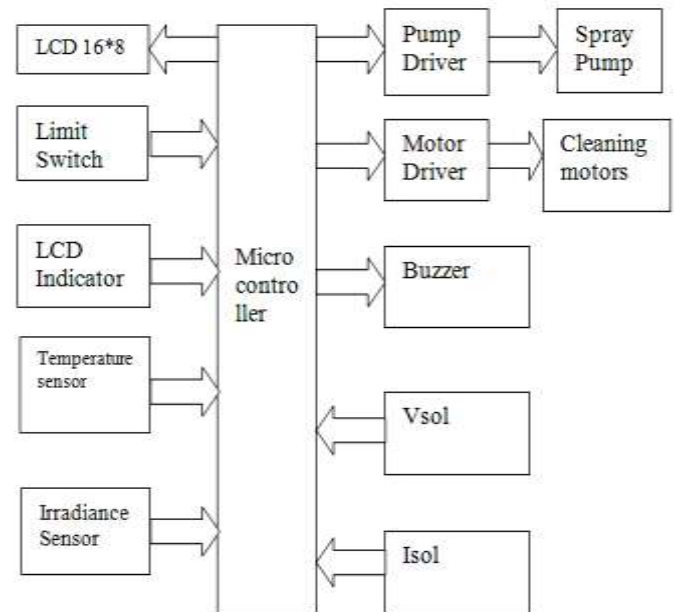

- **Irradiance sensor:** These devices are used for measuring broadband solar radiance as well as solar radiance flux density. Which means that they measure the power of the light and heat from the sun. They work by measuring the number of small peak units of light i.e. photon.
- **Vsol and Isol :** Calculate the solar panel voltage and current respectively and give it to the microcontroller.
- **Limit switch:** Limit switch will limit the path. And when it is pressed the motor will stop.
- **Temperature sensor:** It will sense the temperature and if it goes beyond 35 degrees the pump will start sprinkling water.
- **Pump driver:** It will raise the water to the destination by inducing the force or raising the pressure of fluid.
- **Spray pump:** It is used as a water sprinkler to wash or to cool down the panel.
- **Motor driver:** Used to run a motor, in other words it is used for motor interfacing. They are basically current amplifiers that help to drive the motors.
- **Brushes:** Responsible for scrubbing and dusting away accumulated dust. Brush mounted and radial bearing radials with the help of DC motor to clean the surface.

5. WORKING

The system has major equipments such as brushes, sprinkler, motors, etc. The cleaning system has brushes mounted on it. The brushes rotate in clockwise direction and

the overall system moves in back and forth direction along the solar panel. While moving on the solar panel the system will force the dust along with it on the entire path. As it reaches down the lower end of the solar panel the limit switch will be pressed and the motors will stop and then the system will again move towards the upper end. When it reaches to the upper end then it will move the system in parallel path to clean the remaining system. The pump driver will help to lift the water to the destination. The water sprinklers are used to sprinkle the water on the surface of the solar panel. Which will also help to maintain the temperature of the solar panel?

The system will first measure the power generated by the solar panel and the output of irradiance sensor. Then it compares the solar panel power with the Irradiance power and if the power generated by the panel is less then only the system will start the cleaning action. Also if the temperature of the solar panel increases beyond certain level then the system will start to sprinkle the water on the surface of the panel. Wifi module is used so that we can get V_{sol} , I_{sol} , I_{rr} , Temp and power at the base station computer.



6. TESTING RESULTS

The Following are the Result Obtained after analyzing the Robot:

- 1) Single robot for single row (row length doesn't matters)
- 2) Brush length can be adjusted according to panel width.
- 3) Timer is set on robot along with dust sensor (whichever is earlier).
- 4) Robot itself is solar powered.
- 5) Designed to run fully autonomous (No human is required)
- 6) Intelligent software control cleaning process.

6.1 POWER SUPPLY :

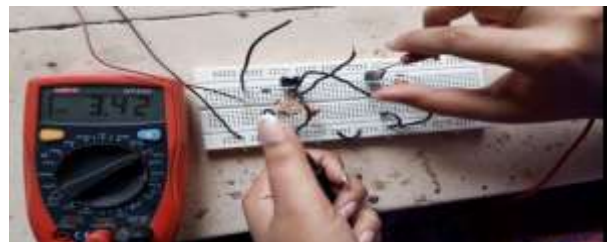
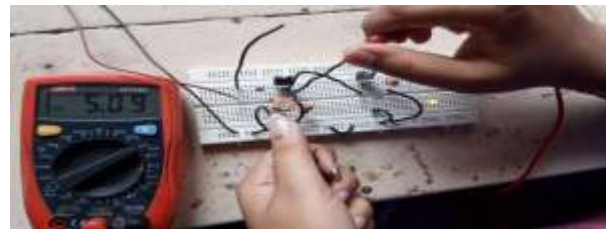

6.2 BUZZER :



6.3 PCB TESTING :



7. CHALLENGES WHILE IMPLEMENTATION

The size of the model should be proper so that it can be fixed on the solar panel.

The system requires highly advanced industrial sensors which are expensive.

One can't always go and check the solar power on the plant so we have to use the wifi model.

8. ADVANTAGES

1. The surface of PV panel remains clean always.
2. No man power is required for cleaning.
3. Efficient & proper cleaning.

4. Less consumption of water.
5. Extend lifetime of solar panel.

- 5) IJSDR1609024 Based on Self-Cleaning Technology for solar PV Panel

9. DISADVANTAGES

1. As brushes are used wear and tear increased.
2. To take care of cleaning water, to avoid nozzles blockages.
3. System is not powered by photovoltaic cells instead it consumes electric power for its necessary actions which leads to additional cost for power.

10. FUTURE SCOPE

1. It can implement on large PV panels.
2. Using LDR sensor, it helps to sense amount of dust on panel and cleans the module automatically.
3. Silicon brushes can be used where it gives max life of cleaning.

11. CONCLUSION

The losses of the output power of the fixed solar panel can be higher depending on the dust form. The dirt and bird drop make the solar panel dirty and it can make temporary fail in the panel. In this system we are using both dry cleaning and wet cleaning methods to clean the surface of the solar panel. Dry cleaning can't remove all the dirt on the surface of solar panel, but it is able to remove the outer layers of the dust. Cleaning solar panel with water increases cleaning efficiency by removing majority of the dirt deposited on the panel. Comparing the costs of cleaning by manual operation and automatic operation, the costs of automatic cleaning is proved to be more economic and significantly less difficult particularly in systems having large number of solar panels. Also cleaning the solar panel whenever the efficiency goes below certain level will minimize the consumption of water and ensures that the solar panel works with a good consistency at all times.

12. REFERENCES

- 1) "MICROCONTROLLER BASED AUTOMATIC CLEANING OF SOLAR PANEL" published S. B. Halbhavi S. G. Kulkarni Dr. D. B. Kulkarni, IJLTET, Vol. 5 Issue 4 July 2015,ISSN: 2278-621X.
- 2) "ROBOTIC DEVICE FOR CLEANING PHOTOVOLTAIC PANEL ARRAYS" Mark Anderson, Ashton Grandy, Jeremy Hastie, Andrew Sweezey, Richard Ranky, Constantinos Mavroid, September 2009, DOI: 10.1142/9789814291279_0047.
- 3) Chandima Gomes, "Impact of Dust on Solar Energy Generation Based on Actual Performance", IEEE International conference Power & Energy (PECON), 2014.
- 4) Performance of Photovoltaic Solar Modules in Sahara Environment"j. Basic. Appl. Sci. Res., 2(11)11030-11036, 2012.