

FABRICATION OF AUTOMATIC PANI PURI SERVING MACHINE

Gudise Santosh Kumar¹, Matam Pavan Kumar², Matrupalley Vineeth³, Parpelly Gowtham⁴

¹²³⁴PG Scholar, Dept. of Mechanical Engineering, CMR College of Engineering & Technology, Telangana, India.

Abstract – Today automation has been an integral part of the food industry as concerns over health and safety have increased worldwide. In this project, we take up a simple local food delight of India, The PaniPuri and design a product that can automate its making process to ensure that the best taste is available to its consumers without concerns over health or safety. The product is designed to take input of puri, boiled chickpeas, masala water and ultimately produce the Pani Puri. The automation ensures that the job is done faster, safer and skill independent. In addition to it, attempt has been made to ensure that standardization of PaniPuri serving process is made such that the taste of the PaniPuri is conserved and ensured every time for consumer. Prototype is designed in SolidWorks and fabricated with the arrangement of four dispensing stations which take the aligned Pani Puri, boiled chickpeas and masala water onto the round rotating table on which rotating plate is mounted with disposable saucer that individually takes the ingredients in required content and serves us after moving through the dispensing channel.

Key Words: Automation, Alignment, Dispensing, Safety, Fabrication.

1. INTRODUCTION

Present food habit has been changed in many aspects around the globe owing to the exchange in cultural, social and economic paradigm change. Pani Puri (spice mixed chickpeas stuffed fried dough/Puri with masala water) is a very popular street snack that has stood the test of time and location. Nevertheless, of its wonderful taste or popularity, the real commercial value of this indigenous food item has never been realized due to several ills like hygiene, unstandardized composition, involvement of skill, etc. In addition to it, unhealthy manufacture practices, improper storage facility and unstandardized composition has been continuously diminishing its popularity since their quality standards vary from Kashmir to Kanyakumari. This popular street item still hasn't reached to several corners of India, let alone the world, since skill is involved which is also a factor influencing taste of Pani Puri.

2. LITERATURE SURVEY

[1] The Design of Machine Elements is an intricate part of mechanical engineering and is a highly essential tool in developing mechanical systems. Khurmi and Gupta has jotted down several rules, criteria and guidelines for the design of various machine elements.

[2] Companies like Nescafe and Le Cube are pioneers in the field of vending machines. Their automatic beverage generating machines have been popular ever since its conception. Their service manual describes the work that have been laid down inside the small machine to produce the required automation in developing the food item.

[3] Mechanical counting in a Gumball machine has been proved to be most effective and has similar features as our problem statement. Several work has been done by inventors and designers over the years in producing variable tweaks in providing a perfect mechanical counting of the Gumballs.

[4] The inception of the idea for the Automated GupChup Machine is seeded by the need of saving a popular street snack from the unhygienic conditions in which it is prepared. A documentary on the issue has been made by Tv9 Gujrat. The issue given there has been taken up by Ankit Kareliya to develop a semi-automatic Pani Puri Machine which takes a little human intervention and produces the GupChup.

3. AIM OF PRESENT WORK

We intended to design an Automated Pani Puri Serving Machine that automates the manual work done by a Pani Puri Seller. We tried to make an Automatic Vending Machine that ensures hygiene, standardized quality and optimum time consumption. It shall take in raw material of Boiled Chickpeas, Masala water, Spices and Puri as input. The set shall consist of three dispensing stations one each of Puri, Chickpeas and Masala water and one Slotting section to punch hole in the Puri to feed the ingredients. We have broken the complete design process in the following subways: -

(i) **Fabrication of a system for discrete Puri Transfer**

The Puri transfer is designed and fabricated to transfer the exact count of PaniPuri onto the plate with alignment.

(ii) **Fabrication of Slotting mechanism**

The Slotting mechanism uses Bolt and Nut mechanism to slot/hole the Puri at a required diameter with required force avoiding cracks.

(iii) **Fabrication of Chickpeas Masala transfer**

The Chickpea transfer is designed and fabricated to transfer the exact volume of masala chickpeas with Centrifugal Pump into the Puri that is already slotted.

(iv) **Fabrication of Masala Water transfer**

The Masala Water transfer is designed and fabricated to transfer the exact volume of masala water with Centrifugal Pump into the Chickpea stuffed Puri that is already slotted.

(v) **Fabrication of Interface and Integrate systems**

All the motors, pumps and table plate rotations are controlled by programmed microcontroller electronics. A system must be fabricated that can work between each individual system and transport the respective food item from one to the other. Finally, the production system is expected to finally delivery.

Three dispensing stations which take the aligned PaniPuri, chickpeas and masala water into the round segmented slotted disposable plate that rotates individually and both along with table and served after the completion of four stations.

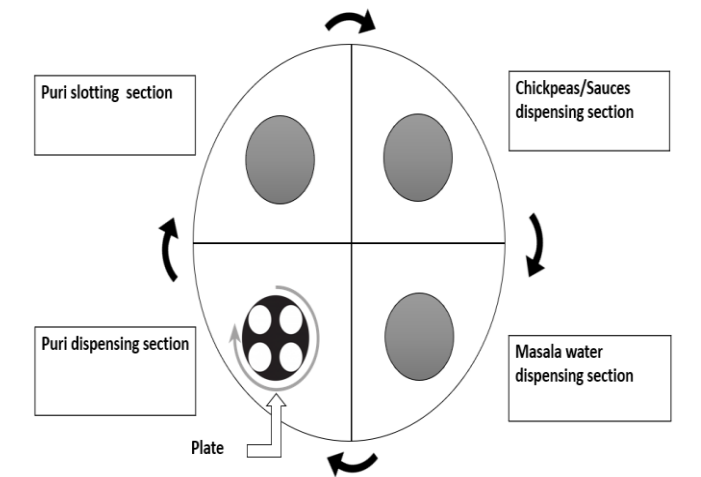

Fig – 2: Mechanism of Rotating Table and Plate

The Puri mechanism is arranged to dispense exact count of Pani Puri onto the plate with perfect alignment. The Slotting mechanism uses Bolt and Nut mechanism to slot/hole the Puri at a required diameter with required force avoiding cracks. The Chickpea dispensing mechanism is arranged to transfer the exact volume of masala chickpeas with Centrifugal Pump into the Puri that is already slotted. The Masala Water dispensing is arranged to deliver the exact volume of masala water with Centrifugal Pump into the Chickpea stuffed Puri that is already slotted.

All the motors, pumps and table plate rotations are controlled by programmed microcontroller electronics as per the flow diagram. This system is fabricated that can work between each individual system and transport the respective food item from one to the other. Finally, the production system is expected to finally delivery. The table exact movements with stop and start functions are given by IR Sensors that are governed by micro controller commands which are powered by an energy source (battery/AC supply).

Arrow indications are made for the direction of the table with respect to the dispensing stations and the plate movement along with the table. Positioning of storage unit for storing 'spherical/elliptical hollow bread ', storage unit for storing water, storage unit for storing boiled Chickpeas.

We even experimented using heater for extra heating chickpeas when stored for long and stirrer for stirring the

4. EXPERIMENTAL SETUP

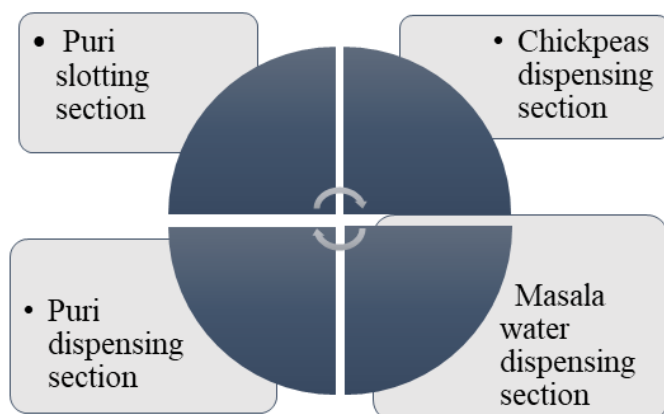

Fig -1: Model of Automatic PaniPuri Serving Machine

sediments of masala water when stored for longer times avoid losing taste.

3. DESIGN

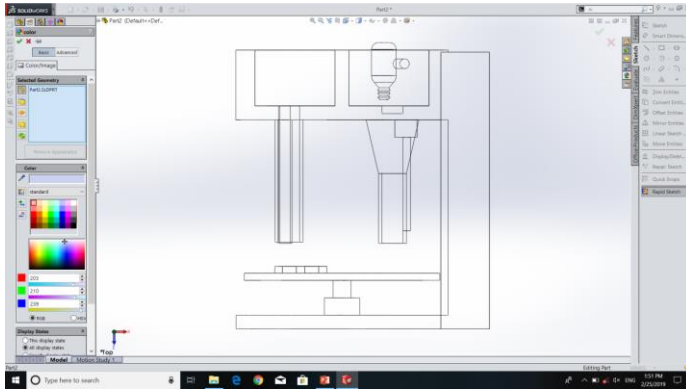

Fig – 3: 2D Layout of the Diagram

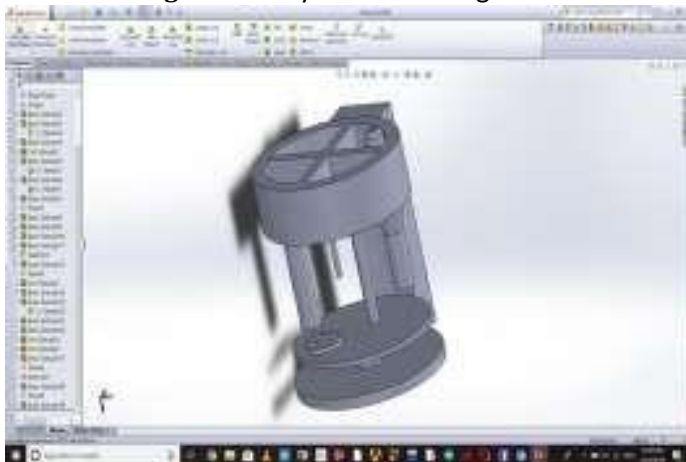

Fig – 4: 3D Layout of the Diagram

5. METHODOLOGY

Design of Rough Sketch of Idea - Idea is scripted for rough space requirement and process planning for the shape and outlook of the machine to be invented.

Design of 2D Figure - Sketch is made into perfectly dimensioned figure in AUTOCAD-2010 with the help of sketching tools and drafted onto A4 sheet for better studying.

Design of 3D Figure - 2D model is exported to SolidWorks-2010 to model fully dimensional rigid figure in 3D with all the required finishing and threading on the model.

Modifications and Finalizing Model - 3D Model is inspected for errors and modifications, according to the purpose and the model stability is checked in real-working conditions by visualization.

Material Planning - Material characteristics required for the storage and operation tools are analyzed based of temperature requirements, hardness, weldability, strength, plasticity and stress-strain properties.

Material Procurement - Material like is procured from nearby hardware shops and cut down into required sizes and thicknesses. Electronic components are bought in an assembled circuit.

Fabrication of Prototype - Prototype is welded to frame and body according to the design, storages are platformed along with motor and pump supports with mechanical work out to perfection with rotation and revolutionary motions of table and plate.

Automation and Programming - Microcontroller is programmed to execute the set of functions by sending commands to IR sensors placed on the mechanical unit to get the accurate locations of PaniPuri transfer medium and exact volumes transfers at dispensing stations in a controlled time with no human effort.

Testing and Modification - System is tested for working and if found unsatisfactory, its modified to get the setup to suit the purpose.

Cleaning and Painting - The equipment is finally cleaned and painted by colors bright and specifically suited for the consumers, this also helps in protecting the system to be rust free and long – lasting.

5.1 PROCEDURE

Puri Dispensing Procedure

Step 1: Firstly, Puris are arranged in a line in the storage and puri is dispensed one by one on to the table.

Step 2: Plate rotates 90° clockwise for each Puri.

Step 3: After all the 4 puri are dispensed the table moves 90° clockwise.

Puri Slotting Procedure

Step 1: When the plate comes into exact position with respect to the Slotter.

Step 2: Slotter moves down and pierces a hole in the puri.

Step 3: After punching a hole the plate rotates 90° to punch the next puri and this goes on until the fourth puri is punched.

Chickpeas Dispensing Procedure

Step 1: When the plate comes into exact position with respect to valve outlet.

Step 2: The valve opens and chickpeas fill the puri.

Step 3: After filling the puri the plate rotates 90° to fill the next puri and this goes on until the fourth puri is filled.

Masala Water Dispensing Procedure

Step 1: When the plate comes into exact position with respect to valve outlet.

Step 2: The masala water is poured into the puri.

Step 3: After filling the puri the plate rotates 90° to fill the next puri and this goes on until the last puri is filled.

5.2 PROTOTYPE FABRICATION



Fig – 5: Fabricated Model

5.3 PROTOTYPE CALCULATION

- Frame - square rod 2 cm side = 30cm*30cm
- Round Table = D= 40cm
- Round Plate = D= 20cm
- Plate and Table Hole = D= 5mm

- Gap between Table and Plate = 1cm
- Storage box size for Pani = 13*20cm
- Storage pipe outer diameter for Puri = O.D. 8cm
- Storage pipe inner diameter for Puri and Chickpea = I.D. 6.5cm
- Storage pipe height for puri and chickpea=30cm
- Volume of Chickpeas in the storage $V = \pi r^2 h$
 $= \pi * 6.5^2 * 30 = 5301.44 \text{ cm}^4$
- Valve diameter of Chickpea storage = 1.27cm
- Expected hole in Puri of PaniPuri = 3cm (max)
- Distance between the center of the hole and circumference of the cover plates = 4.5cm
- Thickness of the cover plates is given 1.5mm due to material availability options.
- The weight of puri = (2) * 9.81 = 0.0196N (approx.)
- Power of the 12V DC 10rpm motor to the blades = $12 * 10 / 1000 = 0.12 \text{ W}$
- Torque transmitted by the 12V DC 10rpm motor to the blades (T) = $0.72 * 60 * 2\pi * 60 = 0.0190 \text{ Nm}$.

6. CIRCUIT DIAGRAM

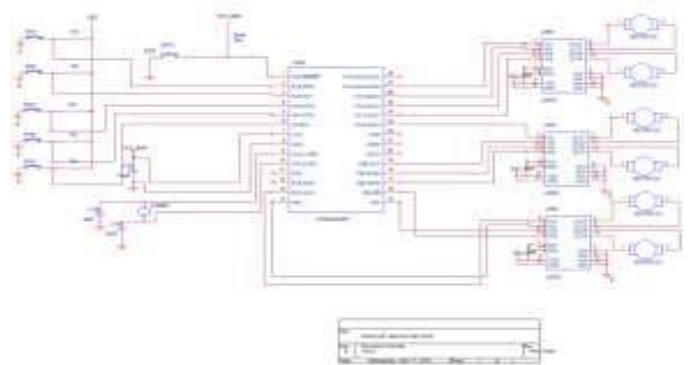

Fig – 6: Circuit Diagram

Equipment	Use	Specification	Quantity
DC geared motor	Slotting Mechanism	12V, working rating 60%	10rpm at 1
DC geared motor	Puri Dispensing	12V, working rating 60%	10rpm at 1
DC geared motor	Boiled Dispensing	Chickpeas 12V, working rating 60%	10rpm at 1
DC geared motor	Table Rotation	12V, working rating 60%	10rpm at 1
DC geared motor	Plate Rotation	12V, working rating 60%	10rpm at 1
DC centrifugal pump	Hotch Dispensing	Water 12V, 70ml/year discharge	1



Fig - 7: Design of Interconnections

7 CONCLUSIONS

The Model has been modified several times to achieve the goal. Firstly, Puri dispensing was made using Rack and Pinion mechanism but number of Puris were falling at same time into the plate so this was replaced by 4 Disc Distribution mechanism was perfectly dropped single puri at a time. Slotting was made using Bolt and Nut mechanism but the tip of slot was modified thrice from circumferential tip to a single tip that was pierce straight into the puri without cracking and not lifting the puri from its position. Chickpea were solid so distribution was not correct and later corrected to semi-aqueous but the acceleration due to gravity was not enough for the Chickpea to drop down so it was made less viscous and altering its ratio with water. Table movements with Plate movement was not in correct sync which was taken care by altering the weight of table and plate instead of using MS Plate, MS Sheet was used. After all the Automation, Pani Puri Serving Machine goal is achieved.

The prototype is fabricated with reference to the design and in purely working condition. The three dispensing stations and one slotting station is perfectly welded to the frame that is highly compactable ensuring hygiene and standardized Pani Puri Serving. This fabrication of automating popular snack has been achieved.

REFERENCES

- [1]R.S. Khurmi and J.K. Gupta, –Theory of Machines, S. Chand Publications, 14th Edition, 2007, pp. 108
- [2]Fully-automatic Espresso Coffee machine http://www.wegausa.com/_docs/pdfs/technicalmanuals/technical_manual_super.pdf
- [3]Le Cube Service Manual Coffee Machine <http://www.computersolutions.cn/blog/wp-content/uploads/2011/09/KrupsCubeNespresso-Service-Manual-xn5005-manual.pdf>
- [4] Gumball Machine and Tv9 Gujarat - YouTube - How delicious Pani Puri is a threat to your life part 1 & 2 <http://www.youtube.com/watch?v=92iZCp75Mpg> <http://www.youtube.com/watch?v=f3fjyQgpy84>

BIOGRAPHIES



GUDISE SANTOSH KUMAR

An Engineering Graduate specialized in Mechanical Engineering from CMR College of Engineering and Technology, 2019.



MATAM PAVAN KUMAR

An Engineering Graduate specialized in Mechanical Engineering from CMR College of Engineering and Technology, 2019.



MATRUPALLY VINEETH

An Engineering Graduate specialized in Mechanical Engineering from CMR College of Engineering and Technology, 2019.



PARPELLY GOWTHAM

An Engineering Graduate specialized in Mechanical Engineering from CMR College of Engineering and Technology, 2019.