

# COMPARISON OF GA AND PSO OPTIMIZATION TECHNIQUES TO OPTIMAL PLANNING OF ELECTRIC VEHICLE CHARGING STATION AT OUR LOCAL DISTRIBUTION SYSTEM

N.Aparna<sup>1</sup>, G.Aruldevi<sup>2</sup>, S.A.Oviya<sup>3</sup>

<sup>4</sup>Mr.K.S.Gowthaman Assistant professor, Government College of Engineering, Thanjavur – 613402, India

\*\*\*

**Abstract** - In this modern world, the need of the transportation increases by every year. So the demand and cost of the fuel are increased and also it leads to causes the air pollution. So switching to electric vehicle is most necessary to pollution free environment. The major hurdle for electric vehicle is to locate the effective charging station (CS) around distribution system. For this, optimal planning is required to place the charging station in our local distribution system. Here, we use Genetic Algorithm (GA) and Particle Swarm Optimization (PSO) techniques for checking optimal placement of the charging station. The data's are collected from the Siruganur substation [110/22 KV]. From this data, energy consumption ratings are brought by load curves to obtain the simulation using GA and PSO. Hence the results of GA and PSO are achieved through MATLAB simulation codes. Finally Real and Reactive power losses are determined by MATLAB program to locate the desirable Electric Vehicle Charging Station at the distribution system in Siruganur, Trichy.

**Key Words:** Electric Vehicle (EV), Charging Station (CS), Genetic Algorithm (GA), Particle Swarm Optimization (PSO), MATLAB.

## 1. INTRODUCTION

In this century, the number of vehicle usage increases rapidly every year. Due to this, pollution also increases enormously. So we move on to the Electric vehicle. The allocation of charging station for Electric Vehicle on the distribution side is the major problem. This problem will overcome by allocating the charging station optimally by optimization techniques. The optimal placement of charging station is obtained by using GA & PSO techniques.

In this project, Genetic Algorithm(GA) and Particle Swarm Optimization(PSO) are utilized for finding optimal placement of charging station in our local distribution system i.e. Siruganur, Trichy. The solutions of GA and PSO are inspected and compared. From this analysis, the best result is chosen for the better placement of charging station.

### 1.1 Genetic Algorithm (GA)

Genetic Algorithm (GA) was introduced by John Holland. It is a random search algorithm based on the concepts of natural

selection and process which is applied in optimization problems. To solve this problem, GA modifies some genetic operators such as selection, crossover and mutation by maintaining the population of individuals. First, it randomly initializes the population and determines the fitness value from each individuals in the population. Repeatedly select parent from the population and perform crossover on parent to creating population. After the population is created, it performs mutation of population again to determine the fitness value. The best solution is obtained by repeating the above mentioned process.

### 1.2 Particle Swarm Optimization (PSO)

PSO was introduced by Kennedy and Eberhart. It is based on population and social metaphor of birds. PSO is particularly similar to the GA and generally known as an evolutionary computation. It is a computational method that solving the problem iteratively to get the optimal result. It improves the algorithm functionality and enhances the quality of solution to achieve the desired goal for the complex problems. PSO gives the best solution as well as GA. Particle Swarm Optimization technique is easy to implement and by adjusting the few parameters the best result is achieved as compared to Genetic Algorithm (GA) in some criteria's only.

## 2. LITERATURE SURVEY

We were taken the PSO technique because it has a relatively new and powerful intelligent evolution algorithm for solving optimization problems. It is a population based approach and it is for the optimal setting of Optimal Power Flow (OPF) based on Loss Minimization (LM) function. [1]

The optimal battery charging station for Plug-in Electric Vehicles (PEVs), by using the Particle Swarm Optimization (PSO) technique is used from this reference paper in [2].

Placing & sizing of CS through simultaneous optimal planning is studied in [3]. We have chosen this paper in order to compensate the relevant problems such as investment cost, system reliability, Power loss, Voltage profile and Environmental issues. Here Genetic Algorithm (GA) is used to solve the optimization problem.

A comprehensive real time analysis of the world charging, driving is mentioned in [4] and energy consumption patterns

of electric vehicles and charging stations deployed in a town. This paper results indicates that the most charging events last fewer than 3 hours and most battery EV's are localized in GA.

In paper [5], a metropolitan city is considered for locating charging station at various regions. During the implementation analysis, an algorithm based on grid and location priority has been designed. GA has been used to demonstrate through other algorithms adopted to meet the priority.

The feasibility of optimally utilizing Ontario's grid potential for charging PHEV during off-peak periods is analyzed in [6]. Based on a simplified transmission network of Ontario's electricity, the optimal solution is obtained. The penetration level is within an acceptable limit for the placement of EV'S and PHEV'S.

They add a new operator to GA to prevent premature convergence and to improve the efficiency of the algorithm. Optimization location scheme for Electric Charging stations determines the necessary number of charging stations and their best optimal placement. The optimization location scheme for Electric Charging stations is useful to reducing the convergence time. [7]

In the improved genetic-particle swarm optimization algorithm(IGA-PSO) integrates crossover of GA and evolutionary mechanism of PSO. The scroll plate optimization on computer shows the improved approach that converge the better solution much faster than the earlier all cases. [8]

### 3. PROBLEM IDENTIFICATION

Increasing the usage of vehicle leads to pollution and then fuel consumption also increased. This leads to demand on fuel resources. Due to this, demand cost is increased. Because of this problem, we move on to Plug-in Hybrid Electric Vehicle (PHEV). The major problem arising in PHEV's, their allocation of the charging station location.

Another problem is that, the Electric Vehicle only run by a battery. The charge stored up by this battery depends on the capacity of the battery. It is not sufficient for all situations. In those critical situations additionally fuel system (IC Engine) may be used (for high speed, fast fuel filling in emergency situation, etc). Hence we move to Plug-in Hybrid Electric Vehicle (PHEV).

### 4. PROPOSED METHODOLOGY

The proposed method would be helpful in developing the electric vehicle infrastructure with minimum cost associated with planning, development and maintenance. The stress on the existing power network due to inclusion of the charging stations must be minimal with the proposed method of solving the optimization problem using GA or PSO.

The charging stations are optimally located in areas with high residential and inter-city electric transportation services as it is needed to provide the charging station for the urban consumers without any difficulty.

### 5. BLOCK DIAGRAM

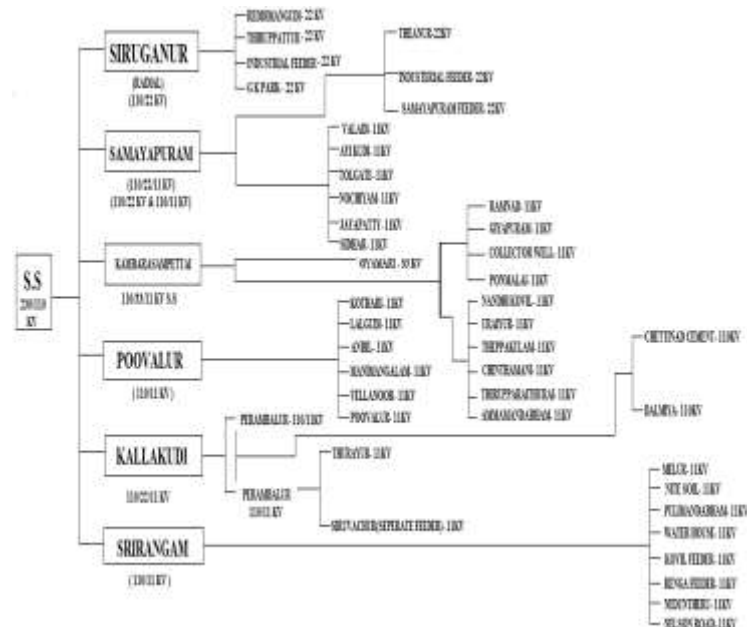

Fig: 5.1 General diagram of overall distribution system.

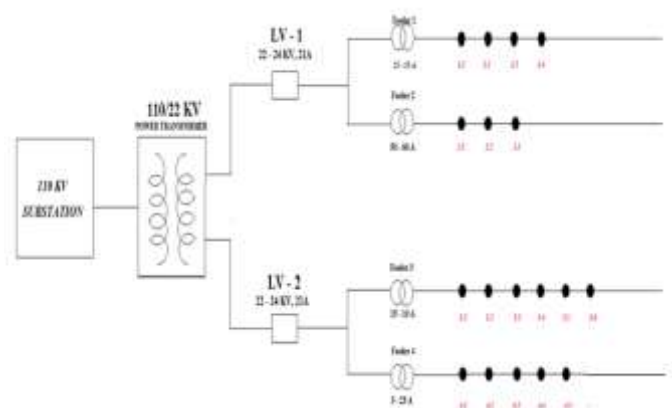

Fig: 5.2 Block diagram for Siruganur distribution system (chosen station)

### 6. TABLE -1

SL.NO.	VOLTAGE (KV)	CURRENT (A)	POWER FACTOR (COS φ)
1.	22 - 24	25 - 35 (Feeder 1)	0.75 - 0.99
		50 - 60 (Feeder 2)	
		15 - 40 (Feeder 3)	
		05 - 25 (Feeder 4)	

As we took four feeders, the voltage and current ratings are tabulated (used in Simulation).

### 7. LOAD CURVE

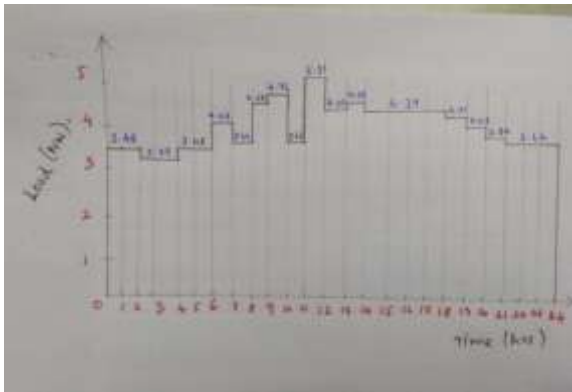

fig: 7.1 load curve

The load curve is drawn between the load in MW and the time in hours.

### 8. TABLE-2

SI. NO	ALGORITHM	BUS SYSTEM	TOTAL LOSSES	
			REAL POWER LOSS(MW)	REACTIVE POWER LOSS (MVar)
1	GA	6	0.322	-59.021
2	GA	14	12.494	25.098
3	PSO	6	1.159	-59.172
4	PSO	14	12.515	25.191

On considering GA technique, it needs many iteration for its optimization and so it takes more time with the minimum amount of power loss for optimal solution. Now considering PSO technique, it needs lesser number of iterations to achieve final result it takes minimum time for optimal solution.

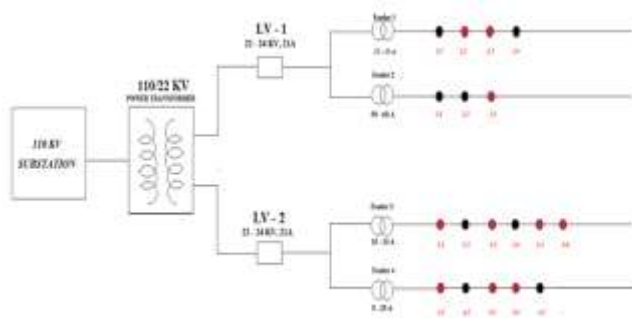

FIG: 8.1 Location of optimal charging station on the Siruganur distribution system.

### 9. CONCLUSION

This paper presented the optimal placement of Electric Vehicle Charging Station at the distribution system in Siruganur, Trichy. The optimization techniques GA and PSO gives the result for the better placement of Electric Vehicle Charging Station. The results from GA and PSO provides the losses at the chosen distribution sides by simulation. The loss values received from GA and PSO are analyzed and compared to obtain the best solution for placing the Electric Vehicle Charging Station around the distribution system.

### REFERENCES

[1] Ahmed Esmim, Germano Lambert-Torres., (2012). "Application of particle swarm optimization for optimal power system". *International Journal of Innovative Computing, Information and Control*.

[2] Kulsomsup Yenchamchalit, YuttanaKongjeen, Krischonme Bhumkittipich, Nadarajah Mithulanathan., (2018). "Optimal sizing and location of the charging station for Plug-in Electric Vehicles using the Particle Swarm Optimization(PSO)". *International Electrical Engineering Congress (iEECON)*

[3] Samaneh Pazounki, Amin Mohsen Zadah Shahab Ardalan, Mahmand-Reza Haghifam., (2015). "Simultaneous planning of Plug-in Electric Vehicle charging stations and distributed generations considering financial, technical & environmental effects". *IEEE Received on February 18, 2015; Accepted on May 13, 2015.*

[4] Huawei Yang, Yabiao Gao, Kathleen Blair Farley, Mike Jerue, Jason Perry, Zion Tse., (2015). "EV usage & city planning of charging station installations". *2015 IEEE Wireless Power Transmission conference.*

[5] Sanjeevikumar Padmanaban, Ramazan Bayindir, Eklas Hossain., (2019). "Electric Vehicle charging station location analysis and determination". *IEEE 9 September 2019*

[6] Hajimiragha .A, Caizares.C.A, Fowler.M.W& Elkamel.A., (2010). "Optimal transmission to plug-in hybrid vehicle(PHEV)". *Transactions on Industrial Electronics.*

[7] Sara Mehar, Sidhi Mohamed, Senouci., (2013). "An optimization location scheme for Electric Charging stations (OLoCs)". *International conference on Smart Communication in network Technologies (SaCoNet).*

[8] Bin Peng, Li Zhang, Hongsheng Zhang., (2006). "Scroll plate optimization based on improved genetic-particle swarm optimization algorithm (IGA-PSO)". *6<sup>th</sup> world congress on intelligence control and automation.*