

SMART PROTECTION JACKET FOR WOMEN SAFETY

V.BHAVANI¹, K. PRUDHVI KRISHNA, V.BHARGAVA³, SK.TASLIMA⁴, V.GANESH⁵, K.DEEPTHI⁶

^{1,2,3,4,5}Student, Dept. of Electronics & Communication Engineering, SACET, Chirala, Andhra Pradesh, India

⁶Assistant Professor, Dept. of Electronics & Communication Engineering, SACET, Chirala, Andhra Pradesh, India

Abstract: We are probably living in the worst time where safety of women has given utmost priority. In homes, on streets, in public transports and even offices, Indian women are in a constant state of vigilance. Women are thinking about their safety mainly when they are alone at the night times. A lot of NGO's, rehabilitation centers and so many helpline numbers have been made in use but all those are not exactly the correct solution to eradicate harassment against women. There are certain preexisting mobile applications that do send message to the saved contact numbers but none of them are much effective. This project focuses on a security system that is solely to serve the purpose of providing security and safety to women so that they feel jubilant while facing such social challenges. In this project, Smart Protection Jacket is designed by placing the components namely ARDUIN NANO, GPS modem (NEO6MV2), GSM modem (SIM800L), Fall detection sensor (ADXL335), Buzzer, Push button switch and Shock circuit inside it. This Jacket can be used by a woman at any time if she is in threat. The Jacket gets activated by using a push button switch. It then starts tracking the location by using the GPS modem. GSM modem helps in sending the alert messages, calls to the registered contact numbers while the buzzer rings and allows the nearby people to act immediately and help the victim. A shock circuit is also used for self-defense. In case if a woman is not in a position to press the push button then the activated fall detection sensor which is also present inside the jacket will analyze the body position depending upon her fall moment and sends the location and alert messages to the registered contacts through GPS and GSM modems.

Key Words: Push button, ARDUINO NANO, GPS modem, GSM modem, fall detection sensor, Buzzer, Shock circuit.

1. INTRODUCTION:

The position of women in India has gone through many great changes over the past few millennia. In modern India, women are still facing social challenges and are often victims of violent crimes. Even in this modern era women are thinking twice before coming out of their house because of increasing crime rates in our country. Especially women working in corporate sector are facing more issue with the security during night shifts. This modern society has given equal rights for women to compete in any field with men even news about women harassment is more than women achievement.

Where technology is rapidly growing and new inventions are being created day by day even then women are facing a lot of problem about their safety. This is the duty of an every individual to create an environment where women must feel safe and secured mainly when they are alone.

1.1 PROBLEM STATEMENT:

The problem arises whenever there is any critical situation that cannot be handled by herself i.e., when a woman is in danger they become very helpless that they may not be in a position to operate their mobile phone even though there are many mobile application for women security. She may not defend herself from the attacker.

Taking this as a problem into consideration, designing of a smart protection Jacket is very much needed. This Jacket can be easily carried out anywhere and comfortable to use at any time.

1.2 OBJECTIVE:

The main objective of this paper is to design a smart protection Jacket. This jacket acts as a shield to protect her against any attacks during night.

2. LITERATURE SURVEY:

[1]Self-defense device with GPS, GSM and fingerprint verification for women safety describes about, push button switch which is a finger print module for device activation, GSM/GPS module for alerting and location tracking, an electronic glove is used and all are connected to a micro controller.

[2]A novel approach to provide protection for women consists of different sensors like pulse rate sensor, temperature sensor, flex sensor, sound sensor, MEMS accelerometer. This device senses the body temperature, moment and voice of the victim if the sensor crosses the threshold then the device gets activated.

[3]There are many mobile applications like mobile apps i.e., I safe app, with u app, Raksha App, Nirbhaya app, watch me app etc. All these apps are used to get the location of the women and then make an alert call to the respective contact numbers.

[4] Women safety device consists of an ARM controller and mobile application at which both are in contact with each other by using Bluetooth module. It will track the location of the women and send the alert message to the registered contact numbers by using GPS and GSM modems.

[5] Fall detection sensor for elderly explains about Android, fall detection sensor based Emergence SMS alert for elderly people. This design of this device combines both software and hardware mainly detecting and reporting the fall indication.

3. BLOCK DIAGRAM:

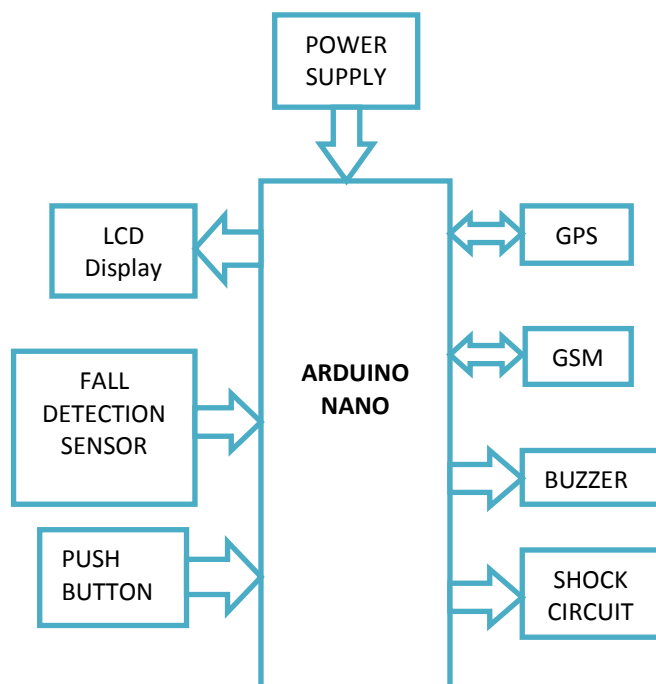

Fig-3: Block diagram of the project

3.1 DESCRIPTION:

ARDUINO NANO:

ARDUINO NANO is a microcontroller board works with ATmega328p micro controller. The board is equipped with set of 14 digital and 8 analog input output pins. It is interfaced to various expansion boards and other peripherals for different applications. The power supply for the board is given by using mini USB connection of 5V. ATmega328p is an 8-bit micro controller worked on AVR RISC architecture. It is one of the best AVR controllers and is used in many ARDUINO boards.

GPS:

GPS means Global Positioning System. GPS is used to track the location of the user. The location is traced in the form of latitude and longitude coordinates. GPS NEO6MV2 is having inbuilt ceramic patch antenna, EEPROM memory,

battery, and LED indication. The operating voltage of GPS is 4.3V – 5.7V.

GSM:

GSM means Global System for Mobile Communication. The operating voltage of GSM SIM800L is 3.4V – 4.4V. GSM is used to send the alert messages and calls to the registered contact numbers. The working of GSM modem is based on AT (ATtention) commands, where these AT commands are given to the GSM modem with the help of micro controller.

FALL DETECTION SENSOR:

The fall detection sensor ADXL335 acts as a sensor device and a hardware component that detects the body position, motion and fall moment. It is operated with very low power of 3V.

BUZZER:

The buzzer is directly connected to the ARDUINO board. Buzzer is used to produce the continuous sound at an audible range of 40-80 db. It is mainly used to alert the nearby people if there is any emergency situation.

LCD:

LCD means liquid crystal display. A 16x2 LCD display is very commonly used device, where each character is represented with 5x8 pixel matrix. It operates at 4.7V-5.3V. It consists of 16 pins.

SHOCK CIRCUIT:

Shock circuit generates some voltage when a push button is triggered. It is helpful for the women to protect herself from the culprit.

PUSH BUTTON:

It is an emergency button used to activate the women safety jacket and also used to produce electric shock and buzzer indication.

4. WORKING:

Smart protection jacket consists of an emergency button, when a woman who is in danger presses that panic button, micro controller gets turned on. GPS MODEM, GSM MODEM, buzzer, shock circuit will get instructions from the micro controller and perform the respective operations. Buzzer indication makes the continuous siren to grab the attention of the nearby people; shock circuit will produce some voltage by that she can defend herself from the attacker while GPS will track the location of the victim and send the information to their parents, relatives by means of GSM modem in the form of messages and calls.

Whenever if a woman is not in a position to press any button i.e., when she was beaten or when she met with any chloroform, then at that time fall detection sensor will be in use. This sensor senses the motion of the user, if there is no moment in her body for certain threshold limit i.e., when she fell down, then depending upon her bending angle and position of her body, this sensor notices the readings and send to the micro controller. Then microcontroller again sends the instructions to the GPS, GSM modems, and buzzer, and again same operation is performed.

5. FLOWCHART:

The below shows the flowchart of the women safety jacket

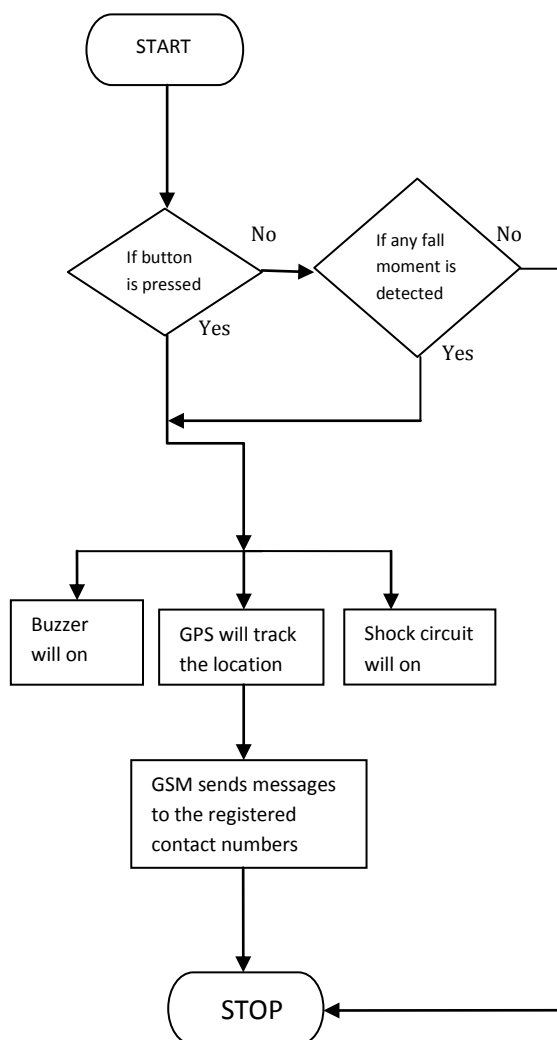

Fig-5: flow chart of the project

6. RESULTS AND CONCLUSION:

The proposed smart protection jacket is very helpful for the woman who is actually in need. Finally GPS modem (NEO6MV2) tracks the location of the victim and forwards

the messages to the respective contact numbers by using GSM modem (SIM800L), and where the location of the victim is obtained in the Google maps.

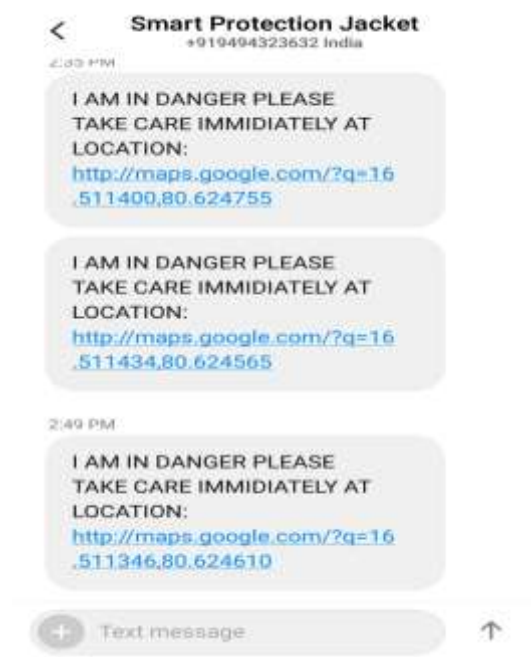

Fig-6: location of the victim

7. FUTURE SCOPE:

- Designing of this type of jacket is very useful but size of the device must be very less and that process can be done by further VLSI size reduction process at which every woman in this world can utilize this device in their daily routine.
- Smart protection jacket can also be used as a children safety device, where safety of children is main concern for parents as well as their school teachers and also this jacket is used for elderly safety.

REFERENCES:

[1] Prof. Basavaraj Chougulau, Archana Naik, Monika Monu, Priya Patil and Priyanka Das, "Smart Girl's Security."

[2] D.G Monisha, M. Monisha, G. Pavithra and R. Subhashin, "Women Safety Device and Application."

[3] K. Manasa, S. Subbalakshmi, Sneha, S. Sowmya, G. Silpa sreeyadhav, "Smart Device for Women Safety."

[4] Kalpana Seelam Assistant professor, K. prasnthi Assistant professor, "A Novel Approach to Provide Protection for Women by Using Smart Security Device."

[5] Remya George, Anjaly Cherian.V, Annet Antony, Harsha Sebestian, Mishal Antony and Rosemary Babu. T, "An Intelligent Security System for Violence against Women in Public Places."

[6] B. Vijalakshmi, Renuka. S, PoojaChennur, Sharangowda, "Self Defence System For women with Location Tracking and SMS Alerting through GSM Network."

[7] Alicia Y.C Tang, Azhana Ahmad, Chin - Hao Ong, "fall detection sensor system for elderly."