

Medicine Reminder System using IoT

Abinaya R¹, Bharath Kumar R², Gopinath S³, Hema D⁴, Boopathi Raja K⁵

^{1,2,3,4} UG Students, Department of Electronics and communication Engineering, SNS College of Technology Tamil Nadu, India.

⁵ Assistant professor, Department of Electronics and communication Engineering, SNS College of Technology Tamil Nadu, India.

Abstract - This task persistent prescription update is a framework which aides in drug organization and checking. This framework comprises of an Arduino Uno microcontroller with an inbuilt EEPROM and a constant circuit. This framework is driven by an installed program that sources of info predefined parameters which are handled dependent on the information factors entered by means of a UI gadget, for example, the keypad. Every one of the sections made on the keypad are simultaneously and all the while showed on the LCD board of the gadget. The rationale for the preparing is incorporated with the inserted program to start the caution through a sound alert. In addition to the fact that it has a caution framework, yet additionally a LCD which shows the drug to be taken at the update time.

The possibility of computerized world where the extraordinary sorts of sensors and neighbourhood preparing associated with share data is utilized in numerous ventures these days. There are different items which are created dependent on these thoughts. Social insurance industry is one where part of upgrades is occurring. The proposed framework comprises of an IOT empowered drug box which gives opportune messages for the patients about their drug time. It alarms the patients to take medications at the appropriate time. The medication subtleties can be recorded in the portable application by the quiet himself or by the guardian of the quiet. The framework jelly track of prescription admission, load of medication, etc.

KeyWords: Internet of Things¹, Medical update frameworks², GSM module³, Arduino⁴, Voice recognition⁵

1. INTRODUCTION

The classification of patients include every single individual educators, understudies, family members and representatives, housewives, youngsters and furthermore we all have a bustling riotous calendar. The present life is loaded with obligations and stress. So individuals are inclined to illnesses of various sorts and it is our obligation to make ourselves remain fit and solid. On the off chance that the patient remains at home, at that point the individual may get somebody to care for him/her in any case, when one isn't at home, is out of the city or state away from home then it is hard for the relatives to call them and remind them their measurements timings inevitably. In our creating and innovation subordinate life we absolutely depend on contraptions particularly brilliant telephones. Today everybody has a PDA. With this we get a chance to utilize innovation in a superior way so it tends to be made helpful to us. What's more, it has a significant influence in our every day life also, encourages us remaining fit from multiple points of view. The noteworthy issue is that patients neglect to take the best possible drugs in legitimate extent also, in legitimate time. Drug adherence, which alludes to the degree or degree to which a patient takes the correct medicine at the opportune time as indicated by a specialist's solution, has as of late risen as a major issue on the grounds that numerous investigations have detailed that non-adherence may basically influence the patient, along these lines raising therapeutic costs. Prescription non adherence is a typical, complex, and exorbitant issue that adds to poor treatment results and expends wellbeing care assets. So we are presenting an Android application whose goal is to help the patients to remember their dose timings through Alarm Ringing framework with the goal that they can remain fit and sound. Through route they can look through specialists and emergency clinics and contact subtleties with the goal that they can without much of a stretch get legitimate treatment on schedule. This application focusses on the individuals who neglect to take prescriptions on time. It enables clients to set a caution alongside the fields of date, time and medication depiction which will enable them to set alert for various meds at various time interims.

The warning framework will send a notice in the wake of setting an alert. The client can initiate or deactivate the warning in like manner. It will be sent as email or message as chose by the client. The patients can look through specialist illness insightful and territory savvy which will give simple looking office alongside specialist's contact data, visiting spot and accessibility time. Drug updates help in diminishing prescription administering mistakes and wrong measurements. The application is structured on Eclipse. It tends to be useful in protection part and crisis conditions (mishaps) and can spread social insurance mindfulness. It is life-sparing, cash sparing and efficient application which is anything but difficult to utilize and gives a decent UI.

2. EXISTING SYSTEM

The existing framework depends on Android Operating framework which will remind the clients to take meds on time through notice and programmed caution ringing framework.

Android is a Linux-based working framework structured fundamentally for contact screen cell phones for example, PDAs and tablet PCs, created by Google related to the Open Handset Alliance. Android was developed starting from the earliest stage empower designers to make convincing versatile applications that exploit each of the handset brings to the table. The framework is indicated on android working framework simply because the piece of the overall industry of Android is high. Android likewise accompanies an application advancement structure (ADF), which gives an API for application improvement and incorporates administrations for building GUI applications, information get to, and other part types. The structure is intended to streamline the reuse and mix of segments. Android applications are fabricated utilizing a compulsory XML show record. The show record qualities are bound to the application at arrange time. This record gives basic data to an Android stage for dealing with the existence cycle of an application. Instances of the sorts of data incorporated into a show record are depictions of the application's parts among other structural and setup properties. Segments can be one of the accompanying sorts: Exercises, Services, Broadcast Receivers, and Content Providers. After login the patient will have the option to see the rundown of all the enlisted specialists with their names, contact data, telephone numbers, medical clinic/center location, the accessibility of specialist as needs be and all other data which the Specialist registers at the hour of Signing into the framework. They can see the dropdown perspective on the infections and can straightforwardly explore to the rundown of Doctors. It additionally shows the following meeting with the Doctor. This encourages the patients to discover the Doctors infection astute. The administrations help them to comprehend the framework appropriately with the goal that it winds up helpful and beneficial. Prescription updates help in diminishing drug administering mistakes and wrong measurements. The Update framework comprises of two sections – setting Alarm and getting notice.

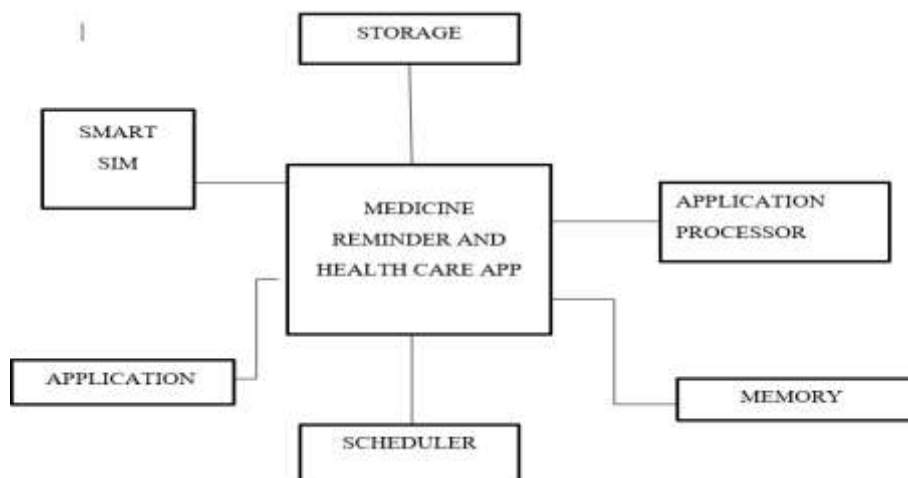

3. PROPOSED SYSTEM

The Medicine reminder system, which consists of pill box with a set of compartments. The typical individuals can utilize it effectively for their medicine. The control arrangement of pill box comprises of LEDs for giving the visual alarms to the patient for medication. There is ringer in the framework which alarms the patient in sound structure. It will buzz for specific time, inside that time just the individual need to press the key by taking the medication, generally the alarm will be given as SMS to the overseer of the patient by GSM that patient has not taken the drug at the time endorsed by the specialist. The ringer and LEDs are giving the cautions at the correct time set by the guardian.

Thus the Smart Medicine system, will continuously monitor the Patient's health by using the internet of things and which it can also maintain the patients daily dosage level. Thus the medicine has a own timing which is compared to the Real World Clock. If the information matches, the buzzer will go off or else the buzzer will give the alarm sound, which reminds the patients to take the medicine. A data can be maintained the patient's health and his/her daily intake of medicines.

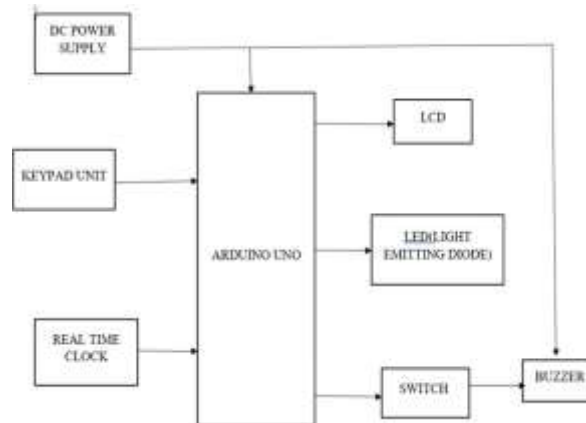

Arduino

Arduino is an open-source stage utilized for building gadgets ventures. Arduino comprises of both a physical programmable



Fig-1: Arduino

bit of programming, or IDE (Integrated Development Environment) that keeps running on your PC, used to compose and transfer PC code to the physical board.

The Arduino stage has turned out to be very famous with individuals simply beginning with gadgets, and in light of current circumstances. Not at all like most past programmable circuit sheets, the Arduino needn't bother with a different bit of equipment (called a software engineer) so as to stack new code onto the board - you can essentially utilize a USB link. Furthermore, the Arduino IDE utilizes a streamlined form of C++, making it simpler to figure out how to program. At last, Arduino gives a standard structure factor that breaks out the elements of the miniaturized scale controller into a progressively available bundle.

Gsm

GSM (Global framework for portable)/GPRS(General Packet Radio Administration) is SIM900 Quad-band GSM/GPRS gadget, chips away at frequencies 850MHz,900MHz, 1800 MHz and 1900MHz. It is compact in size and simple to use as fitting in GSM modem. The modem is structured with 3V3 and 5V DC TTL interfacing hardware which enables client to legitimately interface with 5V controllers (PIC, AVR, 8051, Arduino, and so on.) and 3V3 controllers (ARM, ARM Cortex XX, and so on.). The modem can be interfaced with a microcontroller utilizing USART (Universal Synchronous Asynchronous Receiver and Transmitter) highlight (Serial correspondence)

LCD

LCD(Liquid Crystal Display) is a kind of level board show which uses fluid gems in its essential type of activity. LEDs have a huge and shifting arrangement of utilization cases for shoppers and organizations, as they can be normally found in cell phones, TVs, PC screens and instrument boards

**Fig-2:LCD**

LCDs were a major jump as far as the innovation they supplanted, which incorporate light-discharging diode (LED) and gas-plasma shows. LCDs enabled showcases to be a lot more slender than cathode beam tube (CRT) innovation. LCDs devour substantially less power than LED and gas- show shows since they take a shot at the guideline of blocking light as opposed to radiating it. Where a LED discharges light, the fluid precious stones in a LCD creates a picture utilizing a backdrop illumination.

As LCDs have supplanted more seasoned showcase advances, LCDs have started being supplanted by new show advances, for example, OLEDs.

RTC

RTC implies Real Time Clock. RTC modules are just TIME and DATE recollecting frameworks which have battery arrangement which without outer power keeps the module running. This keeps the TIME and DATE state-of-the-art. So we can have precise TIME and DATE from RTC module at whatever point we need. The correspondence among controller and module is extremely intricate. Normally the data is sent or got byte to byte. So utilizing libraries which are composed for the module DS3231 is perfect. Utilizing libraries makes the correspondence simple. You should simply download these libraries and call them in programs. When the header record is incorporated, the controller plays out the correspondence independent from anyone else and gives the date and time to you. The morning timer can likewise be set or changed effectively utilizing libraries.

Also, when the power goes down, the RTC module chip draws the power from battery source associated with it naturally. So the time will be modern. What's more, when the framework restarts the controller can get the continuous from module without blunder.

4. RESULTS & CONCLUSION

There are numerous frameworks that are filling a similar need. In any case these frameworks are hard to utilize, non-versatile, costly and a complex procedure. The proposed framework defeats the majority of the above issues and it is just moderate with better precision. This framework is useful to each age gathering. It is supportive for following normal medication admission and diminishes manual supervision and human exertion. With the straightforward hardware also, modest gadget comes as a shelter for the youthful and older, a straightforward answer for moms for their young people and guardians for the matured and enduring. It can discover its utilization in each family or on the other hand emergency clinic that has therapeutic supervision and can be advertised as a productive answer for us. The principle objective of the framework is to give sound, strain free life to the individuals who are taking pills routinely and to give it at a moderate expense.

REFERENCES

1. Beena Jimmy and Jimmy Jose (2016), "Patient Medication Adherence: Measures in Daily Practice", Oman medical Journal.
2. Bryant.S(2014) , "OO Principles: Encapsulation and Decoupling". Retrieved January, IOSR Journal of Electrical and Electronics, Vol.1.03, No.6.
3. D. Raskovic, T. Martin, E. Jovanov(2018), "Medical Monitoring Applications for Wearable Computing," The Computer Journal, 47(4): 495-504.

4. Google, "Activity". Retrieved January (2014) Available: [11] Google, "Fragments". Retrieved January, 2014 Available: [12] Google, "Fragment Transaction".
5. H.-W.Kuo(2019), "Research and Implementation of Intelligent Medical Box," M.S.thesis, Department of Electrical Engineering, I-Shou University, Kaohsiung, TW.
6. Kovac M (2015) "E-Health Demystified: An E- Government Showcase Computer", vol.47, no.10, pp.34, 42.
7. L.E. Burke, (2016) M.A. Styn, S.M. Sereika, M.B. Conroy, L. Ye, K. Glanz, M. A. Sevick, L. J. Ewing, "Using mHealth technology to enhance selfmonitoring for weight loss: a randomized trial", American Journal of Preventive Medicine, Vol.43, Issue 1, Pages 20–26.
8. Mrityunjaya D H, Kartik J Uttarkar, Teja B, Kotresh Hiremath (2018), "Automatic Pill Dispenser", International Journal of Advanced Research in Computer and Communication Engineering ISO 3297:2007 Certified Vol. 5, Issue 7.
9. NurmizaBinti Othman and OngPekEk (2016), "Pill Dispenser with Alarm Via Smart Phone Notification", IEEE 5th Global Conference on Consumer Electronics.
10. Park, KeeHyun & Lim, SeungHyeon (2017), "Construction of a Medication Reminder Synchronization System based on Data Synchronization", International Journal of Bio-Science and Bio-Technology, Vol.4, No. 4, pp1-10.
11. R.S.H. Istepanian, E. Jovanov, Y.T. Zhang,(2017) "Guest Editorial, Introduction to the Special Section on M-Health: Beyond Seamless Mobility and Global Wireless Health- Care Connectivity," IEEE Transactions on Information Technology in Biomedicine, 8(4): 405 - 414.
12. Samir V. Zanjali, Girish R. Talmale(2015), "Medicine Reminder and Monitoring System for secure Health", International Conference on Information Security & Privacy (ICISP2015), Nagpur, INDIA
13. S.-C. Huang, H.-Y. Chang, Y.-C. Jhu and G.-Y. Chen, "The intelligent pillbox-design and implementation," in Proceedings of the IEEE International Conference on Consumer Electronics, May 26-28, Taiwan.
14. Shaantam Chawla Mechatronics Research Laboratory Academy for Technology and Computer Science Hackensack, NJ 07601 USA(2016), "The Autonomous Pill Dispenser: Mechanizing the Delivery of Tablet Medication", 7th Annual Ubiquitous Computing, Electronics& Mobile Communication Conference(UEMCON) IEEE .
15. T.L. Hayes, J.M. Hunt, A. Adami and J.A. Kaye (2016), "An electronic pillbox for continuous monitoring of medication adherence," in the processing of the 28th IEEE EMBS Annual International Conference, Aug. 30-Sept.3.
16. Zao, J.K., Wang, M.Y., Peihuan, T. and Liu, J.W.S., (2016) "Smart Phone Based Medicine In-take Scheduler, Reminder and Monitor", IEEE e-Health Networking Applications and Services (Healthcom), pp 162-168.