

AUTOMATED ELEVATOR-AN ATTENTIVE ELEVATOR TO ELEVATE USING SPEECH RECOGNITION

K. Srilatha¹, B. Reeshma², M.V. Sirisha³

¹Assistant professor, Department of Electronics and Communication Engineering,
Bapatla Women's Engineering College, Andhra Pradesh, India

Abstract - Elevator has over time become an important part of our day-to-day life. It is used as an everyday transport device useful to move goods as well as persons. In the modern world, the city and crowded areas require multiform buildings. According to wheelchair access laws, elevators/lifts are a must requirement in new multi-stored buildings. The main purpose of this project is to operate the elevator by voice command. The project is operating based on voice, which could help handicap people or dwarf people to travel from one place to another without the help of any other person. The use of a microcontroller is to control different devices and integrate each module, namely- voice module, motor module, and LCD. LCD is used to display the present status of the lift. The reading edge of your project is the "voice recognition system" which genet's exceptional result while recognizing speech.

Keywords: Arduino UNO; Smart Elevator; Voice-Controlled; Bluetooth Module; Embedded System.

1. INTRODUCTION

The elevator is very common for us nowadays. The use of elevators is expanding in different applications like those are used in carrying goods and carrying people vertically in tall buildings like offices, shopping malls, and other skyscrapers, with increasing technological advancement the reliability is getting worse. Some inventions are not even portable and require great efforts to handle. Therefore, we have decided to come up with a new idea, which is fascinating, as well as helpful. It tries to make it more automatic through your project Speech recognitions a technology in which the system understand the words but not it meaning of the words. Speech is an ideal best and ideal method for controlling the elevator. Automatic speech recognition is a technique by which a computer takes a speech signal and converts it into words. Microcontroller to gives an appropriate command to all attached devices uses those words.

1.1 ARDUINO:

Arduino is an open-source programmable circuit board that can be integrating into a wide variety of projects both simple and complex. The arduino can interact with a large array of outputs such as LEDs, motors, and displays. Because of its flexibility and low cost.

1.1 WORKING PRINCIPLE:

The working of the Arduino microcontroller is where the proper connection is made by checking all input ports as well as the power supply connection. The output of the pins can be connecting with external devices. The program to be executed for the applications can be done by using Arduino software so the software can work on c and c++ programming language. By using, these programs can be uploading to the Arduino microcontrollers. we can control the speed, microcontroller by using the power jack cable the direction and also the number states of a motor program can be uploaded to the microcontroller, This Arduino ATMEGA328 software and again can be uploaded to the Arduino microcontroller are the most suitable microcontroller via power jack cable.

2. Block Diagram:

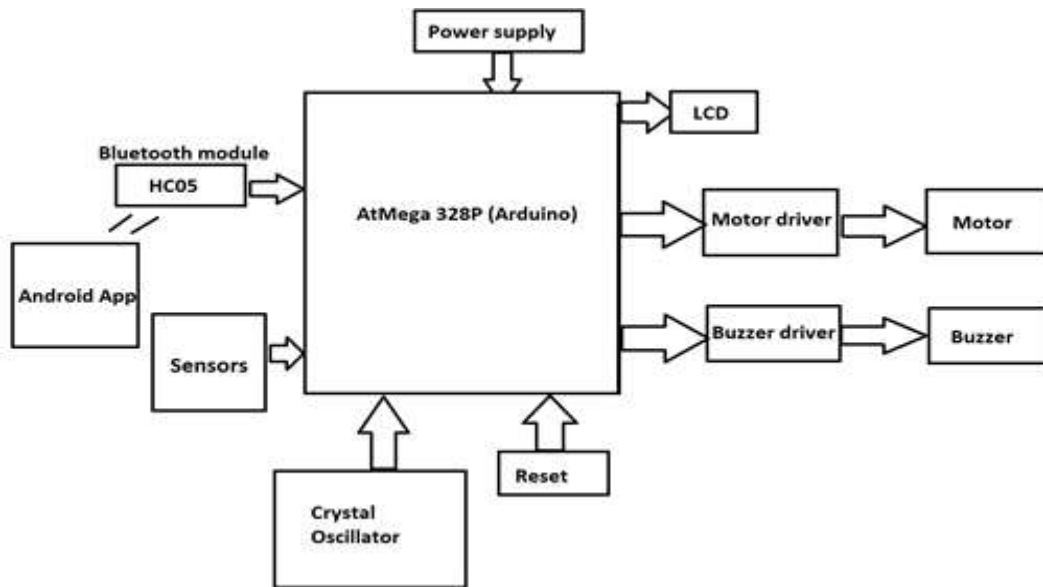

Fig: Block diagram of the elevator

The above figure shows the overall view of the elevator. Here we are using a power supply, Arduino Uno, Bluetooth module, sensors, crystal oscillator, reset, LCD, buzzer driver, motor driver, and android App. Firstly power supply is connected to Arduino Uno, it has the input power of +12V DC. The incoming power is 230V AC; there is a need to convert into +12V DC. The input AC supply is stepped down from 230V to 909V.

Sensors are connected to the Arduino board, it takes input and gives the information in terms of logic 0 and logic1. If the port maintains logic high state when it is of state and if maintain logic 0 when it is ON state.

Bluetooth module is an HC-05 module and it is a wireless device. We can use this module to communicate between two microcontrollers like Arduino to phone or laptop. It has two operating modes one is the data model and the other is the AT command mode.

The oscillator is a microcontroller is operating in the rate of 11.059 to mega Hz frequency with help of quartz crystal connected to Xtal1, Xtal2.

Relay is a switch, which is used to opening and closing the electronic device. It used to operate the external solenoid from any external device, which controls the Motor and Buzzer drivers

2.1 Circuit Diagram:

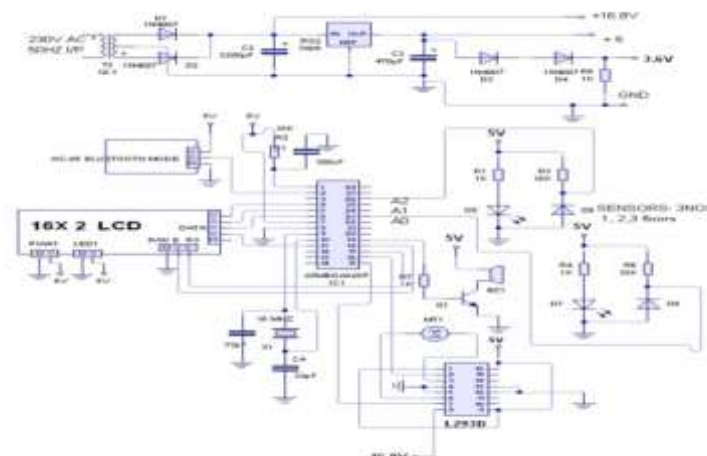

3. Pin Description:

Arduino Uno microcontroller board based on the Atmega-328p is used. It is the heart of the voice control elevator. It consists of 14 digital inputs and output, 6 analog inputs, a 16-mega hertz quartz crystal, USB connection, power Jack, ICSP header and a reset button. The pin diagram of Arduino is shown below.

Port b contains PB0, PB1, PB2, PB6 ports. PB0 is an ICP1/CL.it works as a timer/counter1of input.PB1 acts as an OC1A and it works as a timer counter1 output compare match A output.PB2 it acts as a SS/OC1B. Besides, it works as a timer counter 1 output compare match B output. SS means the SPI slave select input. This pin is low when the controller act as a slave.SPI means a serial peripheral interface for programming.

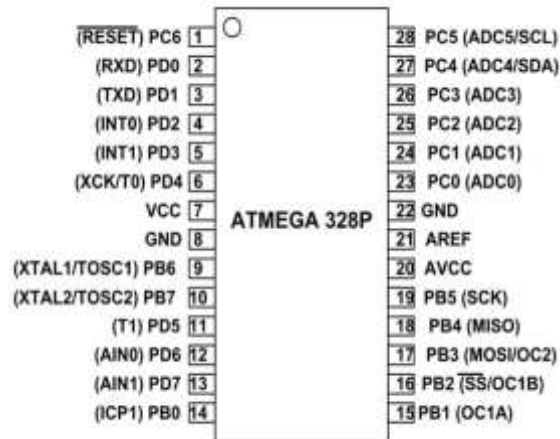

Fig: Pin description of ATMEGA-328P

The PB3 pin acts as a MOSI/OC2A. It works as a timer counter 2 output and compares match output. The PB4 is acting as a MISO. PB5 works as an SPI bus serial clock (SCK). PB6 and PB7 act as a chip clock oscillator pin1 and pin2 or external clock input and timer oscillator pin1 and pin2 respectively.

The port c consists of a PB0-PB6. These all are ADC input channels from zero to six.

The Port D having PD0-PD7. PD0 act as a receiver (RTX) data input pin for USART and it can be used for programming. PD1 acts as a transmitter (TXD) of the data output pin for USART.PD2 pin acts as an external interrupts source zero. PD3 acts as an external interrupt source one and OC2B i.e. PWM timer/counter2 output. PD4 acts as a timer0 external counter input and USART external clock input. PD5 is acting as a timer1 external counter input and OC0B i.e. PWM-timer/counter0 output compare match B output. PD6 acts as an analog comparator positive input and PWM-timer/counter0 output compare match A output. PD7 acts as an analog comparator negative input.

VCC is connected to a positive voltage and connected to the ground in GND. AVCC is acting as a power for internal ADC converter. AREF is an analog reference pin for ADC.

4. PROPOSED WORK:

It is projected consists of mainly two components; voice modules and microcontrollers. The voice module is the main part of this project. Voice module provides a communication mechanism between user and microcontroller. The microprocessor is capable to communicate all input and output devices at the same time. Stepper motor is used to move lift upward and downward according to the command of a programmed microprocessor. Visual information about the elevator provided on the LED display. In this project, the demonstration of the working of a lift is simulating with the help of the Arduino board along with the usage of the voice module.

Voice module is used is voice module V2, which operates at 5V. and communicates serially it can store 15 pieces of information, however considering the requirements only used 3 voice signals, for 3 different floats the voice module output the serially to the controller. This system is operating based on voice, so that the voice of any person can be used to control the elevator, the voice signal of any person is converted into hex-code by voice module V2. The programmed Arduino Uno board used that hex code and give the proper task to the stepper motor. The use of a microcontroller is to control different devices and integrate each module, namely- voice module, motor module and LED. LED is to display the

present status of the lift. The communication between integrated modules happens using a minimal three wire RS-232 protocol. Also, a 12v supply is required to be used.

5. SIMULATION AND RESULTS:

The testing is performing in a software simulator named proteus as it consists of microcontroller-associated peripherals. However, the voice module is not available in the simulator. However, still, the access port software provided with the voice recognition module V2 can calibrate the module and as the capability to modify the contents. Therefore, in a way it can be useful as real-time simulation software. However, a real test of the success of the project lies in the uplift/down lift of the floor. Therefore, in a way simulation software are available, but not at the same time and hence the simulation software provided no substitute to the real testing. As this circuit cannot be simulating, any of the software simulators so given below is the proper hardware circuit, which gives the proper understanding of this project. Hence, in this prototype, there is a voice of three floors i.e. first, second, third recorded. When words spoken in the microphone the voice module processes in this voice into signals and lift goes upwards or downwards.

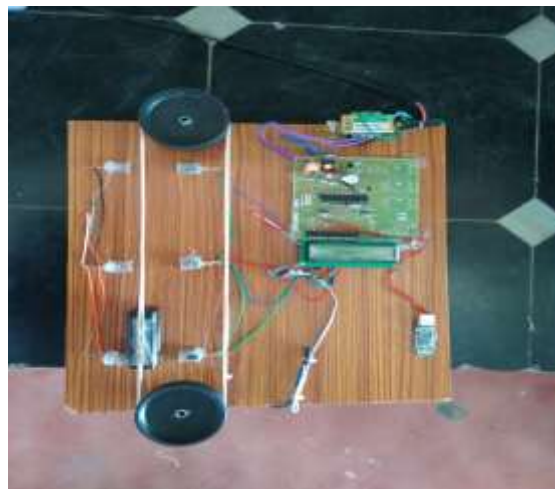

Fig: Simulation Result of Elevator

6. Conclusion:

The voice-controlled elevator is of great use. It works effortlessly. This project tries to throw light on the voice recognition system which can be used to modify the conventional elevator and make it more efficient and usable for physically challenged people. The prototype of the elevator is a useful instrument for research in the specialization of voice signal acknowledgment, computerization, and control advances as well as useful in finding potential applications in this field. this project act as a human-machine communication system.

References:

- [1]. Anne Johnstone-"AUTOMATED SPEECH RECOGNITION: A FRAM WORK FOR RESEARCH " EACL' 85 proceedings of the second conference on European chapter of the association for computational linguistics, page 239-243, Geneva, Switzerland-march 27-29,1985.
- [2]. Reddy, D.R.& Ermann,-"Tutorial on system organization for speech understanding ." speech recognition:invited papers presented at the 1974 IEEE symposium, academic press, page 457-479, 1 January 1975.
- [3] Kaladharan N, Assistant Professor,Dept. of Electrical Engineering. Annamalai University,IJIRCCE, "A study of speech recognition" volume.3,issue 9,page 8030-8034,September 2015.
- [4]. C.H.Lee ; F.k.soong,K.Paliwal"An overview of speaker recognition technology", automatic speech and speaker recognition: advanced topics, Kluwer academic publishers 1996, Norwin,MA.
- [5]. Roger K. Moora, member, IEEE, PRESENCE: A Human inspired architecture for speech-based human-machine interaction IEEE transactions of computers, VOL.56, NO. 9, SEPTEMBER 2007.
- [6]. Arduino technical details –Arduino: A technical reference (Book) a technical ref.by J.M Hughes.

BIOGRAPHYIES:



K.SRILATHA [M.TECH] is presently working as an Asst. Professor in the department of ELECTRONICS AND COMMUNICATION ENGINEERING in BAPATLA WOMEN'S ENGINEERING, COLLEGE, and BAPATLA.



M.V. SIRISHA pursuing B.TECH in ELECTRONICS AND COMMUNICATION ENGINEERING at BAPATLA WOMEN'S ENGINEERING COLLEGE, BAPATLA



B.REESHMA pursuing B.TECH in ELECTRONICS AND COMMUNICATION ENGINEERING at BAPATLA WOMEN'S ENGINEERING COLLEGE, BAPATLA