

# AUTOMATIC MECHANISM FOR LED PARAMETERS TESTING & CHECKING

Saurabh P. Kuhikar<sup>1</sup>, Animesh S. Gupta<sup>2</sup>, Lalit V. Gohane<sup>3</sup>, P. D. Khandait<sup>4</sup>

<sup>1,2,3</sup>Student, Department of Electronics Engineering, K.D.K.C.E, Nagpur, India

<sup>4</sup>Professor & HOD, Department of Electronics Engineering, K.D.K.C.E, Nagpur, India

\*\*\*

**Abstract:** From the past years we are using sodium lamp it consumes more power and voltage, which they lost huge amount of energy. In day to day life to promoting clean energy development in environment, is that the critical issue. Therefore LED lights are majorly used more and more widely in numerous fields, like lighting of homes, for adornment purpose and public places etc. But as per the market survey availability it's two kinds of LED i.e. Branded or Non-Branded LED (local quality), so it's very difficult to decide on from them which is best one because there's no brand tag or logo on LED. Hence our requirements to develop a mechanism that automatically find the parameters of LED with relevance standard datasheet.

**Key words:** LED, LED Driver, Automatic, Parameters, Sensor, Testing and Checking.

## 1. INTRODUCTION

LED is one amongst the electronic components that are used for several purposes in day to day lifetime of soul like decoration purpose for wedding, organizing events, Festivals decoration etc. Regulation of the LED is same as simple ordinary diode and it's fabricated by the assorted kinds of semiconductor (i.e. GaAs). The matter regarded to non standard LEDs is that it gets fused or exploded just in case of abrupt changes in environment and temperature or the variation of input voltage and current also damage the LED. Even when the LED if not fabricated in standard ways; can affect the performance of LED. So our aims to test all parameters of LED that may be done by manual testing, but may have human errors. To avoid this situation; we want to style a mechanism that may automatically check or discover all parameters of LED [1].

The main concept is that the LED must work with long life period, so we cannot calculate the lifetime of LED. But with the assistance of main parameter of LED, the lifetime of LED is calculated. This parameters are Brightness of LED, voltage require to on perfectly, current, power rating, color etc. There's many varieties of LEDs, we consider white LED because this LED is common LED used for indication purpose.

When we apply forward voltage to the diode it'll activate and provides the output within the type of light. And when the reverse voltage is applied then it act as electric circuit (off). LED may be tested and checked using

various parameters like Voltage, Current, Power and Brightness [1]. But the lifetime of LED cannot calculate because of the parameters like excessive current, over temperature or dynamic change in atmospheric condition. Within the market two varieties of LEDs are available (i.e. Branded and Local). The branded LEDs are fabricated in an exceedingly standard way hence its long life with good efficiency as compared to the non branded LED's. To avoid this situations the customer must analyze the fundamental parameters by using digital multimeter, but it's uphill to test all the parameters of LEDs on every occasion. Hence we'd like to style such form of mechanism that may be automatically checked or see.

## 2. COMPONENTS OF PROPOSED SYSTEMS

### 1.1 Arduino UNO

Arduino is belong to family of microcontroller board primarily designs and manufactured by innovative Projects in Italy. Some users are using various 8-bit Atmel AVR microcontrollers or 32-bit Atmel ARM processors. It is provide collection of digital and analog I/O pins which is able interfaced different boards, analog devices and other circuits [13]. It is working on 5 to 12 volt dc power supply. From the above mention two controllers we used 8-bit Atmega-328P in which it consist of 14 pins within that 6 are PWM pins, 6 are analog input pins and remaining are VCC (+5v) and ground. For communication between computer and arduino USB port is available to write the program into arduino. Arduino encompasses an open source platform to write the program in supported programming language i.e. C language it is called integrated development environment (IDE) software which is freely available on site.



Fig -1: Arduino Uno

**1.2 Brightness sensor BH1750 (light intensity module)**

The BH1750 Light intensity Sensor Module is based on the digital Ambient Light intensity measurable Sensor module IC BH1750FVI developed by ROHM Semiconductor. It is a digital IC within in-built function of capability of conversion in 16-bit luminance to digital converter. For transferring the info and communication with external devices like Microcontrollers, the BH1750 Ambient Light Sensor IC uses I<sup>2</sup>C Bus Interface protocol. It has few pins i.e. VCC, GND, SDA, SCL and ADDR. The SDA is used for serial data acknowledgement and SCL pin can provide serial clock pulse to arduino within single clock pulse 16 bit data are often transmitted as shown in fig. 2 [14].



Fig -2: BH1750 light sensor module

**• LCD Display**

For this mechanism it require display for display the parameters of LED. The Nokia 5110 may be a basic graphic LCD screen for several applications. it's wont to display the brightness of LED as shown in fig. 3 [15]. It absolutely was originally intended to be used as a telephone screen. It has a capability to designed to run a graphic display of 48 rows and 84 columns. And another display is 16X2 LCD display has 2 rows and 16 columns. It used to show the power and voltage of LED [16].



Fig -3: Nokia 5110



Fig -4: 16X2 LCD display

**2. LED Driver Circuit**

The LED driver is use to drive the LED in proper Voltage and Current. In fig. 5 circuitry the 12volt DC supply is forwarded from the adapter that can regulate by the IC7805 and get output voltage 5volt. The two switches are used to provide constant source to circuitry our requirement is that at the output end we want two constant current i.e. 150mA and 350mA to run the LED. According to the datasheet of SMD LED when we applied the constant current to LED and we get the 60 and 118.5 lumens. Hence this driver is used to identify the LED can work properly or not when datasheet is concern the overall design is shown in fig. 5.

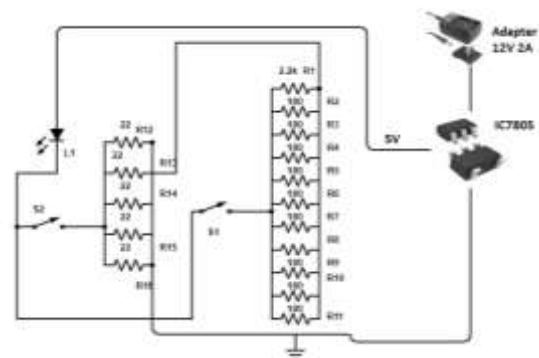

Fig -5: Circuit diagram of LED driver

**3.WORKING OF PROJECT**

First of all we select anyone LED that must be branded or non branded and place into the LED Driver circuit and spending the varied current through the LED. Because the standard LED fabricating companies (i.e. Osram, Bajaj, Eveready, Havells, Bosch etc.)Follow the standard

fabrication rules. Passing the varied currents like 150 mA, 300mA & 500mA through the LED and find the reading across the LED by the help of Arduino microcontroller At mega 328. Here Arduino is that the CPU of the mechanism it program in such way that finds the all the essential parameters of LED which is shown on the displays. As shown in fig. 6 arduino is interfaced by two displays i.e. 16x2 LCD display and Nokia 5110 display [15, 16].

The LCD display is used to display voltage and power with their S.I units and Nokia display is used to point brightness/intensity in lumens/meter. To calculate the brightness of the LED it requires a sensor which can sense the brightness of LED and provides the result to the arduino. There are different types of sunshine sensors like LDR, photodiode, IR sensors, but as per the market survey BH1750 brightness sensor is more efficient and more sensitive. LED require the utmost 5v to indicate on we using the 12V dc power supply that given to LED driver circuit to flow sufficient voltage to indicate on the LED.

To display the voltage across LED the analog pin A1 of arduino is connected to the anode terminal of LED to sense the voltage and process them display the output in LCD display. Power is calculated by formula  $I^2 \cdot R$  which is in in-built arduino code and display the power in LCD display. During this manner we calculate the all parameters of LED. The output is shown in fig. 7.

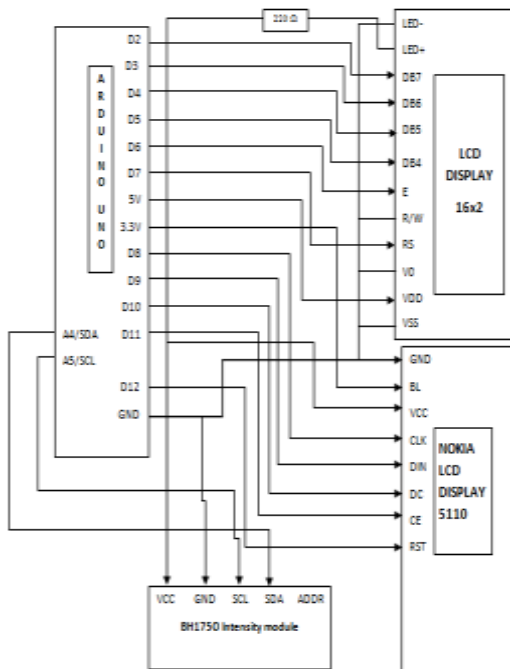

Fig -6: Interfacing modules of automatic mechanism of LED

#### 4. ADVANTAGES

- The user can calculate all the parameters of LED with the help of digital multimeter where human error may be involved because of mishandling of equipment. Our system can avoid the human error by performing automatically.
- It consumes low power because it requires 12V power supply as compared to the high power industrial testing units.
- The system displays all the parameters of LED at a time.

#### 5. PROJECT OUTPUT



Fig -7: Experimental setup

#### 6. CONCLUSION

In day to day life customer can buy cheap products most of the time which are local in order that they are not long life. The system mechanism is employed find all the essential parameters of LED automatically and it are often to assist to differentiate between the branded LED and local LED. Hence this project is used within the LED development industries satisfies the customer requirement, also this more helpful for the LED bulb and halogens development industries or agencies to test and analyze easily. It doesn't require more bulky and high power equipment to check LED.

#### REFERENCES

[1] S. Kuhikar, A. Gupta, L. Gohane and P. D. Khandait, "Automatic Mechanism for LED Parameters Testing and Checking," in International Journal of Research in Engineering, Science and Management, vol. 3, no. 1, pp. 607-608, January 2020.

[2] Obaidur Rahman, Sean Elphick, Kashem M. Muttaqi and Jason David "Investigation of LED Lighting Performance in the Presence of Ripple Injection Load Control Signals," IEEE Transactions on Industry Applications, vol. 55, Issue: 5, Sept.-Oct. 2019.

- [3] Aman Jha and Manoj Kumar, "A Wide Range Constant Current LED Driver with Improved Power Quality and Zero Standby," IEEE IEEMA Engineer Infinite Conference (eTechNxT), 13-14 March 2018.
- [4] Selcuk Sakar, Sarah Ronnberg and Math H. J. Bollen, "Immunity Test of LED Lamps Based on IEC 61000-4-19 and Unexpected Consequence," IEEE 18<sup>th</sup> International Conference on Harmonics and Quality of Power (ICHQP), 13-16 May 2018.
- [5] Yao Bin, Xu Huawei, Zhou Zhenwei, Lu Guoguang, Lai Canxiong and Li Ruguan, "The Study of Natural Exposure Testing for LED Lighting System," 18<sup>th</sup> International Conference on Electronic Packaging Technology, 16-19 Aug 2017.
- [6] Xiaohui Qu, Huai Wang and Xiaoqing Zhan, "A Lifetime Prediction Method for LEDs Considering Mission Profiles," IEEE Applied Power Electronics Conference and Exposition (APEC), 20-24 March 2016.
- [7] Muna E. Raypah, Bashiru K. Sodipo, Mutharasu Devarajan, and Fauziah Sulaiman, "Estimation of Luminous Flux and Luminous Efficacy of Low-Power SMD LED as a Function of Injection Current and Ambient Temperature," IEEE Transaction on Electron devices, vol.63,no.7, July 2016.
- [8] A. Jha and B. Singh, "Power quality improvement using bridgeless-Landsman converter for LED Driver," IET Power Electro, vol. 9, no. 13, pp. 2591-2601, Oct 2016.
- [9] A. Jha and B. Singh, "Modified bridgeless landsman PRC converter for LED driver," 7<sup>th</sup> India Inter. Confer. On Power Electro. (IICPE), Patiala, 2016, pp.1-6, 17-19 Nov 2016.
- [10] Sreedevi V T, "Analysis and Simulation of A Single Stage Power Supply for LED Lighting," International Conference on Green Computing, Communication and Conservation of Energy (ICGCE), 12-14 Dec. 2013.
- [11] Yueh-Ru Yang, "Brightness control of LED lamp using Fuzzy logic Controller," 5<sup>th</sup> IEEE Conference on Industrial Electronic and Application, 15-17 June 2010.
- [12] Do Hung Nguyen, Jaber Hasan, and Simon S. Ang, "A Built-In Self-Test High-Current LED Driver," IEEE 8<sup>th</sup> International Conference on ASIC, 20-23 Oct 2009.
- [13] <https://components101.com/microcontrollers/arduino-uno>
- [14] <https://www.electronicshub.org/bh1750-ambient-light-sensor/>
- [15] <https://lastminuteengineers.com/nokia-5110-lcd-arduino-tutorial/>
- [16] <https://positrontech.in/eshop/product/16x2-lcd-display/>