

MEASUREMENT OF SECOND HARMONIC VOLTAGE WITH WAVELENGTH MODULATION SPECTROSCOPY USING MATLAB SIMULINK

Rupa Sinha¹, Dr. Rekha Mehra²

¹M.Tech Scholar, Department of ECE, Government Engineering College Ajmer

²Associate Professor Department of ECE, Government Engineering College Ajmer

Abstract -In the recent time free-space optical communication systems have garnered significant recognition because of its higher capability it provides path for long distance applications. When FSO is being operated on illegal optical spectrum, it may yield the LOS optical transmission with the advantage of lower price and also better security system. FSO is defined as transference of harmonized visible or IR rays in the airspace for obtaining broadband communication. FSO can be operated over a long distance that can be up to many kilometers. In FSO systems Communication between transmitter and receiver can be done till the time the LOS. But the condition for this transference is that the transmitted power should be so much high that it can overcome the atmospheric losses till the time it reaches to the receiver. Free Space Optical communication systems dependent on WDM technology can provide a speed as high as 1 Terabit/s and much higher capacity according to user requirement. It has some other advantages like they use small size transmitter and receivers, the cost required for their installation and development is not much as compared to other techniques also they are not affected by electromagnetic interference FSO systems came into existence because of higher traffic requirement and security of the communication systems. The links that are involved in satellites, interstellar probes, ground stations, UAVs, long height platform, aircrafts are practically interesting.

Key Words: FSO, WDM, UAV, Spectrum, Intensity, lock-in amplification.

1. INTRODUCTION

In the recent time free-space optical communication systems have garnered significant recognition because of its higher capability it provides path for long distance applications. When FSO is being operated on illegal optical spectrum, it may yield the LOS optical transmission with the advantage of lower price and also better security system. FSO is defined as transference of harmonized visible or IR rays in the airspace for obtaining broadband communication. FSO can be operated over a long distance that can be up to many kilometers. In FSO systems Communication between transmitter and receiver can be done till the time the LOS. But the condition for this transference is that the transmitted power should be so much high that it can overcome the

atmospheric losses till the time it reaches to the receiver. Free Space Optical communication is proffered as compatible technique with the radio frequency technology. FSO provides disorganized BW spectrum that is in terahertz technology also the speed of the data transfer is very high. Due to these advantages FSO is becoming very popular communication technology for satisfying the growing demand of BW traffic mainly for the long distance communication. Free Space Optical communication systems dependent on WDM technology can provide a speed as high as 1 Terabit/s and much higher capacity according to user requirement. It has some other advantages like they use small size transmitter and receivers, the cost required for their installation and development is not much as compared to other techniques also they are not affected by electromagnetic interference FSO systems came into existence because of higher traffic requirement and security of the communication systems. The links that are involved in satellites, interstellar probes, ground stations, UAVs, long height platform, aircrafts are practically interesting.

1.1 Overview of FSO Communication:

FSO communication is the transmission of information/data over long distances using harmonized optical signals in unguided network system. The random communication system can be free space, water, atmosphere or an integration of these Medias. Since the research focuses on terrene transmissions, the main interest is atmosphere. The data to be transmitted can be modulated in its frequency, phase or intensity of the optical signal

1.1.1 FSO Block Diagram:

Figure 1.2 depicts block diagram of classic earthbound FSO network. FSO is also having same configuration as possessed by another communication system. FSO also having three prime systems which are listed below:

- Receiver
- Transmitter
- Communication Channel

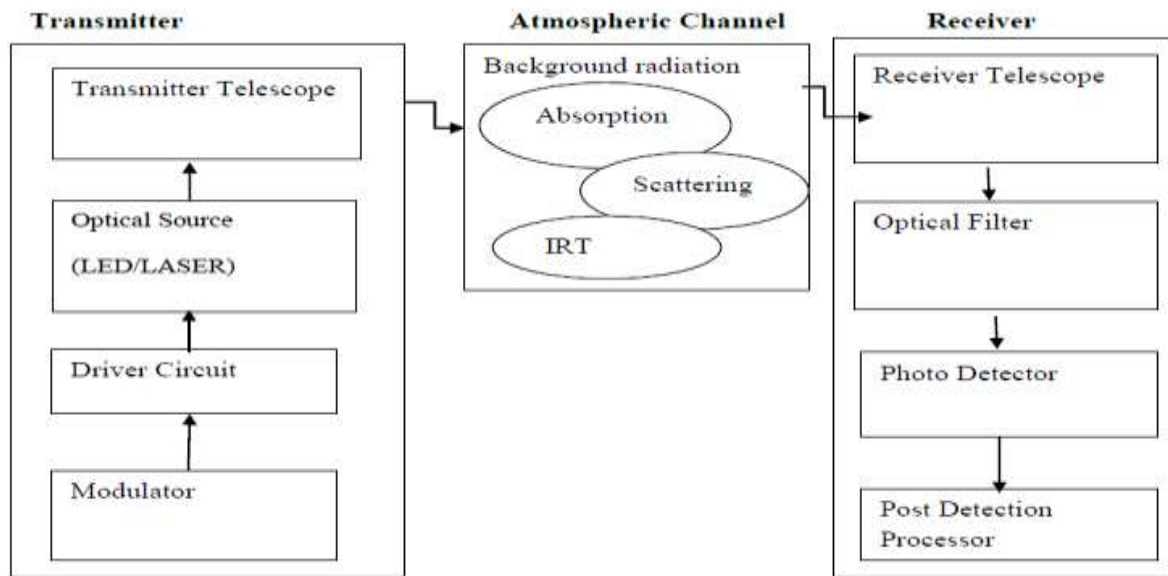

Fig. 1.2 Illustration of FSO with three prime systems

1.1.2 The Transmitter:

As there are three main systems in FSO and every system is designed to do a specific task. Now in first stage transmitter has to execute its crucial task of modulation of message which is originated by source and it must be compatible to travel through optical channel without any loss of signal and must be reached to destination point via atmosphere. The transmitter consist mainly four sub units

- Transmitter Telescope
- Driver Circuit
- Modulator
- Optical Source

Modulator play very prime role and is accountable for proper conversion of initiated message so that it can be compatible with optical channel. OOK modulation technique is one of the fundamental schemes generally utilized in FSO for communications purpose.

1.2 Architectures of FSO:

Designed system must be reliable, robust and should be compatible enough to work in any environment and configuration like ring topology, PTP, mesh topology, PMP and many more as per requirement. With time populations increasing exponentially so to meet the demand of people especially in metropolitan zone, vendors must assist with all types of service with standard QoS band prepares their network as a giant and extend all the services to last person with FSO.

1.2.1 FSO Mesh Configuration:

Figure 1.6 represent FSO mesh configuration which is made up of various sensing nodes couples with each other in series with minute angle of lay-off. In this kind of configuration each node is coupled to each node of network directly or multiple hops in series.



Fig. 1.6 Mesh architecture

1.2.2 FSO P2M Configuration:

In this configuration there would be a single node which generate message and work as a server for other sensing nodes. This node is coupled with many nodes to which information will be shared. Figure 1.7 represent best suited technique of point to multipoint configuration and sites must be close enough



Fig.1.7 point to multipoint architecture

1.2.3 Multiple PTP Architecture:

Figure 1.8 layout multipoint PTP configurations and it is best suited for large scale network to manufacture sensible connection path. In this configuration there is some standard weather parameters must be in consideration during employment of this technique

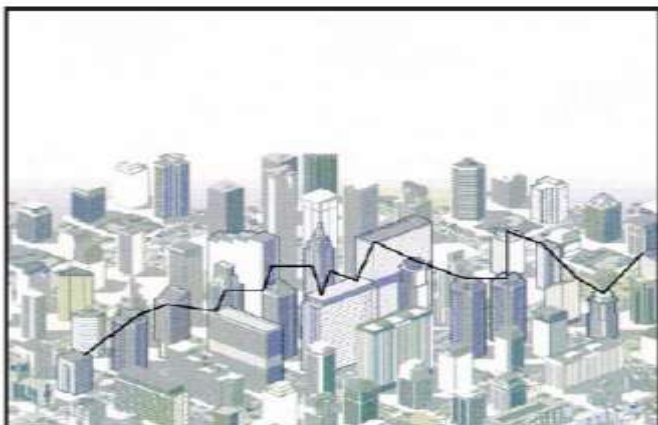

Fig.1.8 multiple PTP architecture

1.3 Challenges Encountered in FSO:

FSO communication promises a very bright future in terms of its high data rate, immunity to electromagnetic interference (EMI) and security.

1.3.1 Atmospheric effects:

There are various communicating channels exist according to signal properties. No channel exists till now who transmit information without any noise or disturbance. Definitely there would be some impact of channel on signal. Optical Scattering

- Optical Absorption
- Index-of-Refractive

Optical signals are impaired by three prime factors which are depicted below due to which signal strength becomes so lower and crucial information may be lost and that would be tedious task to recover again in spite of robust receiver.

- Absorption
- Scattering
- Refraction

1.3.2 Pointing, Acquisition and Tracking System:

PAT techniques have been a serious challenge encountered in FSO. Typical FSO links require a transparent LOS among transceiver.

1.4 FSO Application:

FSO communication system can be deployed in various domains of application like military, civilian [3].

Deep Space Probes: In mission like deep space investigation there are huge restriction on various parameters like mass, volume and power of onboard devices is severely limited and hence therefore size of antenna and transmission power are also limited. According to, lasercom terminals for space investigation have much lower mass with respect to radio frequency unit [5].

Links involving Satellites: FSO path can be used in SC (satellite communications) to establish a global backbone network. Optical links which incorporate satellites provide very high quality service (Gigabits data) even to remote areas such as an island, a rural area or an isolated country. FSO Links involving satellites includes satellite to ground and air, ISL.

Terrestrial Networks: FSO utilized in terrestrial networks to establish a PTP and line of sight optical connection between two transceivers through the atmosphere. Propagation range of light signal through atmospheric channel can be 100 m to 10 Km due to the LOS property. Since data rates of FSO are approximate to FO (fiber optic, this telecommunication pattern can be crucial for broadband internet access.

1.5 FSO Disadvantages:

FSO is a LOS technology in which atmosphere play role of transmission medium. Therefore snow, rain, humidity, visibility, and various obstacles affect communication link.

- Poor Weather
- Physical Obstacles
- Scintillation
- Weather Conditions

Further Weather Condition classified into different section

- Rain Condition:
- Snow Condition:
- Fog Condition

2.1 Objectives and Methodology

In our research work based upon wavelength modulation spectroscopy (WMS) using tunable diode laser. WMS determine concentration, temperature and velocity of absorbing gaseous molecules. Our objective will be

- MATLAB based Digital Lock-in amplifier technique for extraction of harmonics (1f & 2f), from the wavelength modulated optical absorption signal
- MATLAB based program for calculating the oxygen concentration from 1f and 2f harmonics. The oxygen concentration has been measured using MATLAB implemented digital lock-in-amplifier and concentration computation formula. The deviation in the measured Oxygen concentration from the actual Oxygen concentration supplied through the mass flow controllers is less than 1%.
- WMS technique finds major application in industrial and scientific areas. An important component of sensors/systems based on these techniques is the phase sensitive detection for demodulation, in the form of hardware or software based lock-in amplifier.

2.2 Calibration-Free Wavelength-Modulation Spectroscopy

This part depicts a method and implementation of calibration-free WMS that has been developed over the last several years for application in harsh environments. The section begins with a brief overview of traditional scanned-wavelength direct-absorption spectroscopy. The subsequent calibration-free WMS discussion is divided into four parts

- Relevant background
- WMS measurement
- WMS model
- Comparison between the two to infer gas properties

2.3 Scanned-Wavelength Direct-Absorption Spectroscopy

For many years, tunable-diode-laser (TDL) direct-absorption spectroscopy has been the technique of choice for absorption-based measurements of gas parameters in harsh environments because of its simplicity, accuracy, and ability

to make absolute measurements. The diode-laser injection current is tuned with a repetitive ramp waveform (or similar). This has the effect of repetitively ramping the laser intensity and the laser wavelength. If the nominal laser wavelength corresponds to a spectral

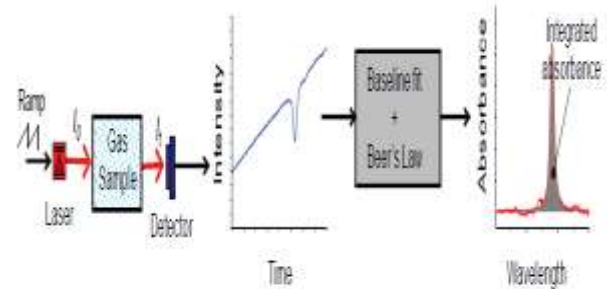

Figure 3.1 Schematic of scanned-wavelength direct-absorption spectroscopy with a tunable diode laser

Absorption feature for a species present in the probed gas sample, the laser is tuned across the feature and results in a detector signal similar to the one shown (intensity vs. time).

$$\alpha = -\ln\left(\frac{I_t}{I_o}\right)$$

Here α denotes the absorbance, I_t is the transmitted laser intensity (i.e. the detector signal), and I_o is the incident laser intensity (i.e. the baseline). The absorbance can be related back to the gas properties of a uniform absorbing medium through the following equation:

$$\alpha = \sum_j S_j(T) \cdot P_i \cdot L \cdot \phi_j(\nu)$$

where $S_j(T)$ is the line strength at temperature T of absorption transition j , P_i is the partial pressure of the target species i , L is the path length of laser beam travel through the uniform absorbing medium, and $\phi_j(\nu)$ is the line shape function at frequency ν (referring to the optical frequency, which is inverse wavelength).

$$\text{Integrated Absorbance} = S(T) \times P_i \times L \times \int_{-\infty}^{\infty} \phi(\nu) \cdot d\nu = S(T) \times P_i \times L$$

The integrated absorbance is directly proportional to species partial pressure (and therefore concentration) and is related to the temperature of the absorbing gas by $S(T)$, which is either measured under laboratory conditions or obtained from HITRAN [22].

For thermometry, the ratio of the integrated area of two absorption features is used. When the ratio is taken, the species partial

$$\frac{\text{Integrated Absorbance}_1}{\text{Integrated Absorbance}_2} = \frac{S_1(T)}{S_2(T)}$$

2.4 Wavelength-Modulation Spectroscopy

Wavelength-modulation spectroscopy (WMS) is similar to direct-absorption spectroscopy, except the laser wavelength is additionally modulated with a rapid sinusoid (at frequency f). This attribute of WMS is particularly useful in harsh environments, and is demonstrated in Figure 3.2. A simple experiment was performed in which a laser was tuned to an absorption feature and the 2f and 1f signals were recorded as the laser beam was partially blocked (left panel), and the laser optics were periodically vibrated (right panel). Despite the large and rapid changes in the laser intensity (which affect both the 2f and 1f signals), the 1f-normalized, WMS-2f signal remains unchanged. Altogether, the benefits listed above yield a 2-100x improvement in SNR for WMS-2f over direct absorption, depending on the measurement conditions. Given these benefits over direct absorption, the technique has been applied to many harsh or difficult absorption measurements.

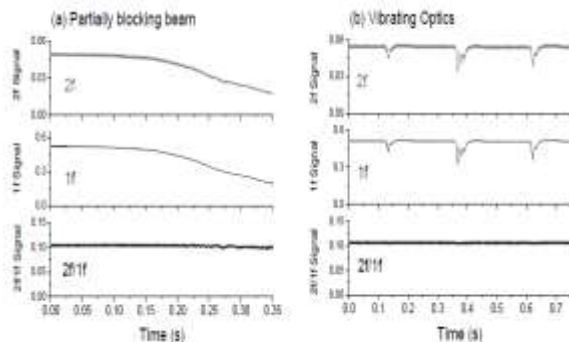

Figure 3.2 Demonstration of 1f-normalization to account for laser intensity perturbations to the 2f signal, (a) the laser beam is increasingly blocked, and (b) the laser optics are periodically vibrated

2.4.1 WMS Measurement

Figure 3.3 shows a schematic of a scanned-wavelength WMS measurement using a diode laser. Much like traditional scanned-wavelength direct-absorption measurements, the diode-laser injection current is tuned with a repetitive ramp waveform.

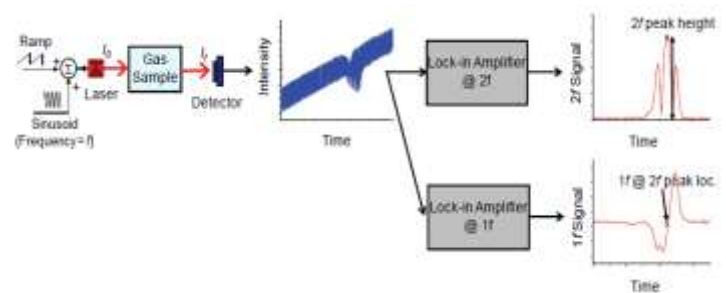

Figure 3.3 Schematic of wavelength-modulation spectroscopy (1f-normalized, WMS-2f). Example data is water-vapor absorption measured in a scramjet combustor at WPAFB. The 2f signal is always positive due to the phase-insensitive lock-in approach taken in these experiments (described below). The slight distortion on the left side of the

2.5 Implemented Simulation Blocks Diagrams:

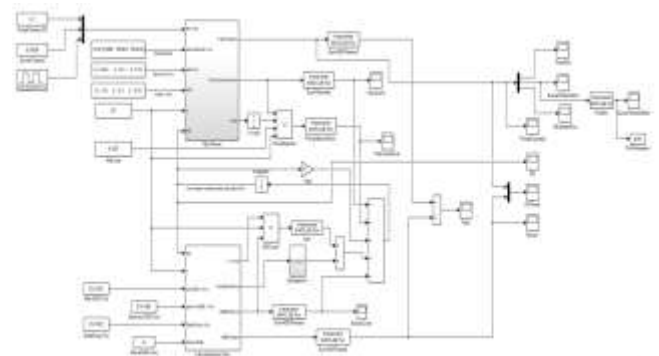

Fig.3.4 Implemented Simulink block diagram

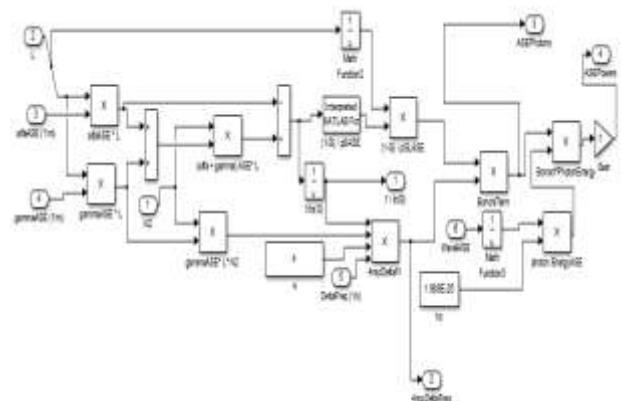

Fig.3.5 Subsystem 1 of implemented Simulink block diagram

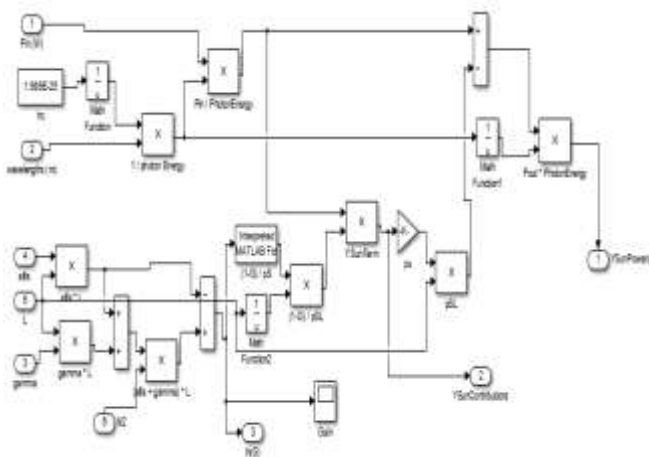
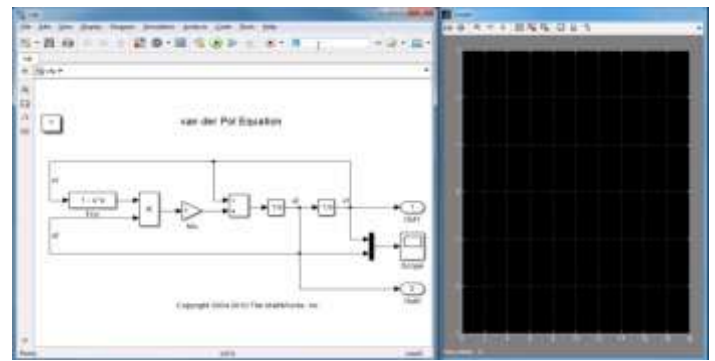

Fig.3.6 Subsystem 2 of implemented Simulink block diagram



3.1.3. Fuzzy Logic System

Fuzzy logic concept is not based on a control methodology, but process the large data by permitting partial set membership function rather than crisp set membership. Professor Zadeh gives the logic that people that they do not need so much accurate, numerical data input, and in spite of this able to control very accurately.

3. Result and discussion

3.1 Software: MATLAB R2015a: Mat lab stands for matrix laboratory and is very powerful software which provides us various tool box and diverse virtual environment for executing different types of problem of different domain as per demand. With help of MATLAB, complex problems can be solved so effectively and rapidly with respect to our classic programming languages for example C, C++, and FORTRAN.

3.1.1. Matlab System

In MATLAB there are five important sections available where research oriented work can be executed. These five domains are listed below:

- MATLAB Scripting Language (.m file)
- MATLAB Simulink Environment
- Graphical User Interface (GUI)
- Mathematical Function Library
- Application Program Interface (API)

3.1.2. Matlab Simulink

Matlab consist different working environment and out of them Simulation in Matlab play very prime role in any research. In this environment anyone can create virtual model before implementing in real life.

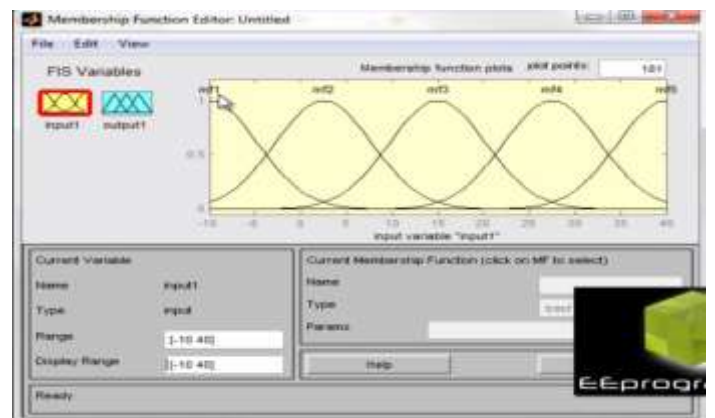

Figure 4.2 Basic diagram of fuzzy logic for different MF

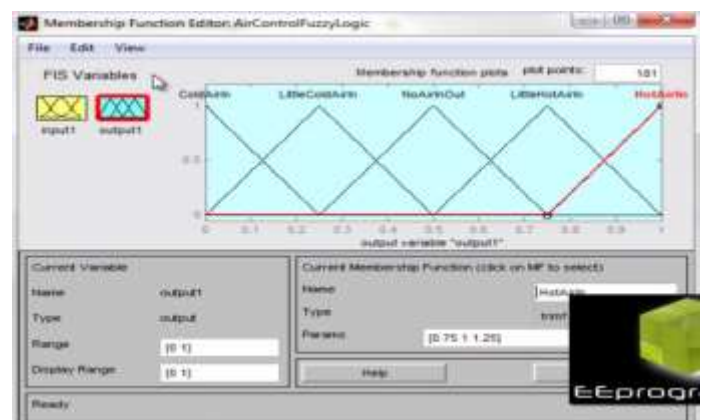

Figure 4.3 air control fuzzy logic illustration

Feedback controllers would be extremely constructive when programmed can be done in such a way that they accept noisy, un-specific input and gives optimized result. FL is a problem-solving control system methodology that lends itself to implementation ranging from simple, small, embedded micro-controllers to large, networked,

workstation-based data acquisition and control systems (DACS) in a system. It can be executed in software, hardware or integration of both.

3.2 Simulation Output:

This section depicts the simulation result carried out

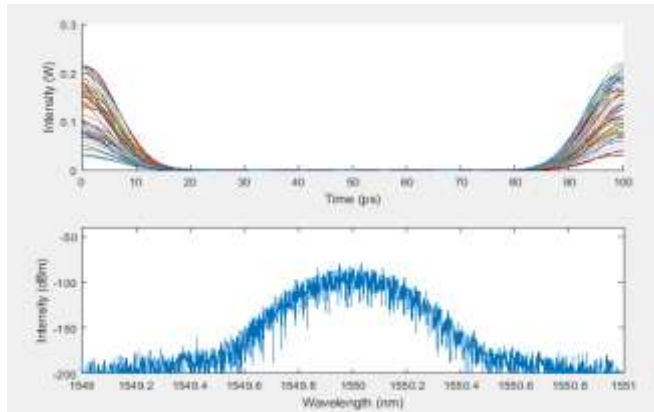

Figure 4.5 Represents Intensity (W) v/s Time (ps) and Intensity (dBm) v/s Wavelength (nm)

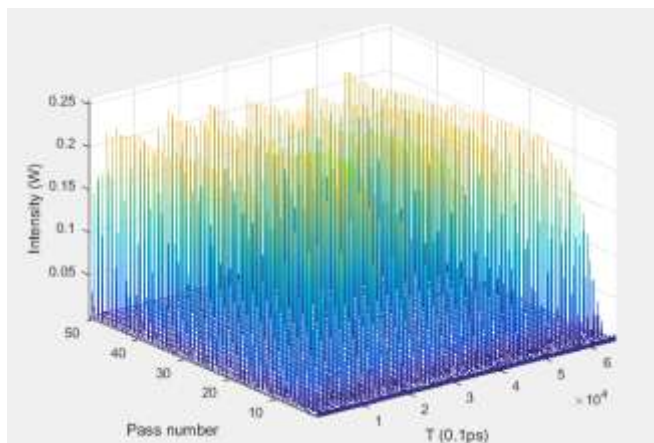

Figure 4.6 Represents 3D relationship between Intensity (W) v/s Pass Numbers and Time (0.1 ps)

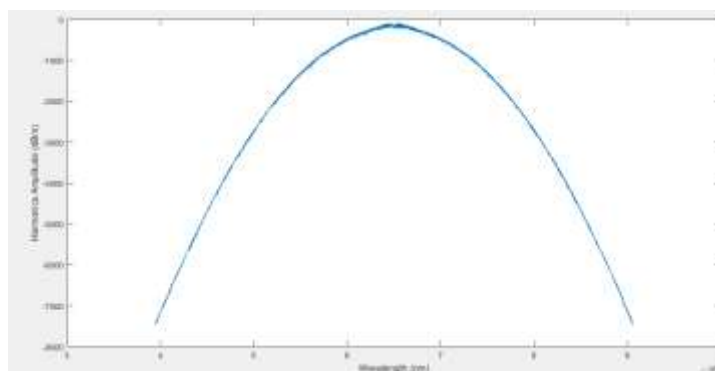

Figure 4.7 Harmonic Amplitude (dBm) and Wavelength (nm)

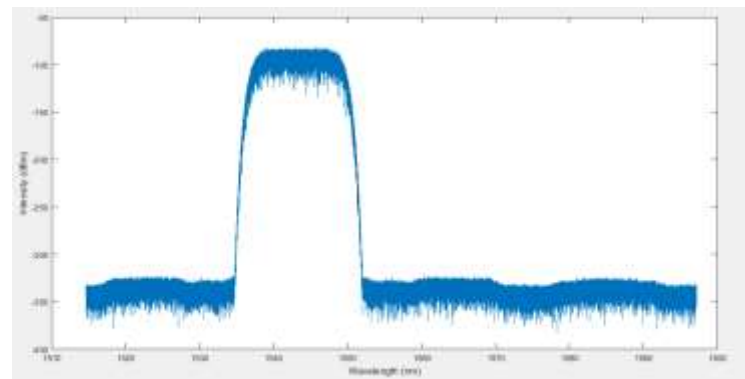

Figure 4.8 Intensity (dBm) and Wavelength (nm)

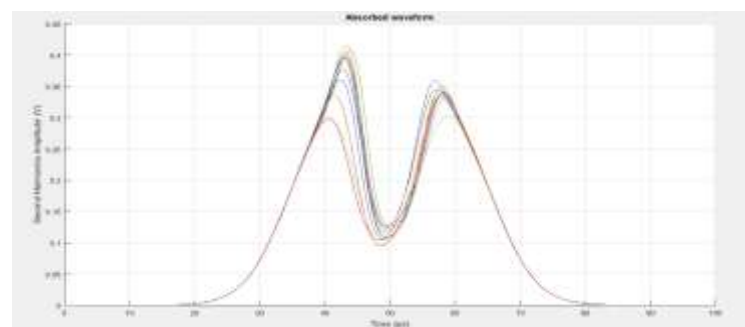

Figure 4.9 Second Harmonic Amplitude (V) and Time (ps)

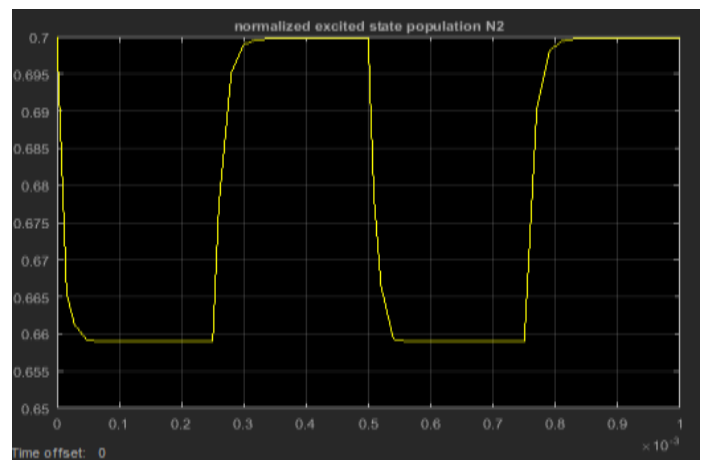

Figure 4.10 Normalized Excited state population N2

4.1 Conclusion:

There are various optical absorption method exist to measure concentration of various gaseous. Earlier hardware systems are used to execute desired result but right now with help of different types of simulation desired results can be achieved. The experimental simulation process uses MATLAB to complete the gas absorption process and a phase sensitive detection or demodulation code is developed in software based lock-in amplifier for the extraction of 1f and 2f harmonics using MATLAB and these harmonics are collected using the method of lock-in amplification. After locking the amplified signal, the larger weakened the higher amplitude of the fundamental signal, the resulting second

harmonic signal to meet the gas detection requirements. we have shown the different graph of Intensity with respect to time and wavelength, we have also shown the 3D diagram of intensity, Pass number and time. The result is obtained between 2nd harmonic and time and also for intensity.

4.2 Future Scope

There are diverse techniques existed for optical absorption and prime concern of research is to fetch out tremendous result in term of second harmonics so that further these harmonics can be used for optimization. Now a day's IoT, AI can be collaborated in optical absorption to get optimized result. As per demand of industry AI and IoT dominating technologies which will cover large part of application in every domain

REFERENCES

- [1] M. A. Al-Habash, L. C. Andrews, and R. L. Philips, "Mathematical model for the irradiance probability density function of a laser propagating through turbulent media," *Opt. Eng.*, vol. 40, no. 8, pp. 1554-1562, Aug. 2001
- [2] X. Zhu and L. Kahn, "Free space optical communication through atmospheric turbulence channels," *IEEE Trans. Commun.*, vol. 50, no. 8, pp. 1293-1300, Aug. 2002
- [3] X. Zhu and L. M. Kahn, "Performance bounds for coded free-space Optical communications through atmospheric turbulence," *IEEE Trans. Commun.*, vol. 51, no. 8, pp. 1233-1239, Aug. 2003.
- [4] M. A. Naboulsi, H. Sizun, and F. de Fornel, "Fog attenuation prediction for optical and infrared waves", *Opt. Eng.*, vol. 43, no. 2, pp. 319-329, Feb. 2004
- [5] X. Wang and K. Kitayama, "Analysis of beat noise in coherent and incoherent time-spreading OCDMA," *IEEE/OSA Journal of Light wave Technology*, vol. 22, no. 10, pp. 2226-2235, 2004.
- [6] T. H. Shake, "Confident performance of encoded optical CDMA", *IEEE/OSA Journal of Light wave Technology*, vol. 23, pp. 1652- 1663, 2005.
- [7] A. Ahmed and S. Hranilovic, "Outage Capacity Optimization for Free-Space Optical Links with Pointing Errors," *IEEE Journal of light wave technology*, vol. 25, no. 7, July 2007.
- [8] V. Jyoti and R. S. Kaler, "Performance analysis of one-dimensional and two-dimensional codes in optical Code division multiple access system", Department of Electronics & Communication Engineering, Thapar University, Punjab, India, 2009
- [9] Hennes Henniger, Otakar Wilfert, "An Introduction to Free-space Optical Communications", *Radio Engineering*, Vol. 19, No. 2, June 2010
- [10] Ashish Kumar, Aakash Dhiman, Devender Kumar, Naresh Kumar, "Free Space Optical Communication System under Different Weather Conditions, *IOSR Journal of Engineering (IOSRJEN)*, Vol. 3, Issue 12 (December. 2013), ||V2|| PP 52-58
- [11] Ritesh A. Jadhav, Dattatraya S. Shitole, "Fiber Optics Communication And Applications", *International Journal of Innovative Research in Engineering & Science* ISSN 2319-5665(April 2013, issue 2 volume 4)
- [12] Francis Idachaba, Dike U. Ike, and Orovwode Hope, "Future Trends in Fiber Optics Communication, *Proceedings of the World Congress on Engineering 2014 Vol I, WCE 2014*, July 2 - 4, 2014, London, U.K.
- [13] Bhanu Priya, "Performance Analysis of SACOCMA-FSO System Using MD Codes", *International Journal of Hybrid Information Technology* Vol.8, No. 5 (2015), pp. 187-194
- [14] Mehtab Singh, "Simulative Analysis of 10 Gbps High Speed Free Space Optical Communication Link", *International Journal of Future Generation Communication and Networking* Vol. 9, No. 3 (2016), pp. 139-144
- [15] Mohamed Bouhadda, Fouad Mohamed Abbou, Mustapha Serhani, Fouad Chaatit and Ali Boutoulout, "Analysis of dispersion effect on a NRZ-OOK terrestrial free-space optical transmission system", *Journal of the European Optical Society-Rapid Publications, Society-apid Publications* (2016) 12:18
- [16] Deeksha Jain, Dr. Rekha Mehra, "Performance Analysis of Free Space Optical Communication System for S, C and L band", 2017 International Conference on Computer, Communications and Electronics (Comptelix) Manipal University Jaipur, Malaviya National Institute o/Technology Jaipur & IRISWORLD, July 01-02,2017
- [17] Satea H. ALNAJJAR, Ammar A. Noori, and Arwa A. Moosa, "Enhancement of FSO Communications Links Under Complex Environment", *Photonic Sensors*, 2017, DOI: 10.1007/s13320-017-0336-1

AUTHOR PROFILE

MS. Rupa Sinha M.Tech. Scholar from Government Engineering College Ajmer.

Dr. Rekha Mehra, working as Associate Professor Department of ECE in Government Engineering College Ajmer.