

Smart Door System

Siddhesh Raorane¹, Abhishek Hanchate², Umar Gigani³, Prof. Surekha Khot⁴

^{1,2,3}Mumbai University

⁴Professor Surekha Khot, Dept. of Information Technology, ACPCE, Maharashtra, India

Abstract - This project is about a smart door system using face recognition based on Raspberry pi. Smart door system has been launched for many years but most of them are just a CCTV, IP camera or door sensor alert system. It could be more efficient with uses of face recognition. The design of smart door system is based on human face recognition and remote monitoring technology. It will verify the person identity that goes near to the camera within certain distance. Only the people who match the identity with database and key in the correct password have the right to entry. A mobile application telegram and image processing technique LBP based have been involved in this system. Electric door lock solenoid.

Also, Smart home automation system is a web-based application that allows user to monitor home appliances using mobile devices. This system established for the entire home user after gaining access from administrator. This system includes remote control home appliances, security. Once all the appliances in home are automated and connected it important to consider issue of security authentication and access control.

1. INTRODUCTION

This project is for provide a precise solution with a new design with improvement embedded system to protect the household with giving higher security level and notification on time. Anyway, there are a few problems that are still exist on security product on market. The issues like the face detection only will start to function when someone press the doorbell. Surveillance system will destroy by theft and without notify owner when stranger come in. Lastly, face recognition can be by pass with owner face photo.

Nowadays, the home security with only door locker is not enough to protect your house and family. However, the smart doorbell system on market still not popular for household uses because of the high price tag. Besides that, the smart home security system on market still can be improved to higher security level and build with low cost material to fulfill the need of market. Regarding to this issue, smart door system using face recognition project have been started for solve this issue. It can help to solve the issues like it can trigger the alarm and capture an image send to owner when a stranger is detected in front of door. The theft will get alert so he got no time to start breaking the door and destroy the security system. For overcome the weakness of face recognition that can be by pass with owner face image so the door will unlock.

The project aims at designing an advanced home automation system using normal web server and Wi-Fi technology. The

devices can be switched ON/OFF by using a Personal Mobile Phone through Wi-Fi. Considering the advantages of Wi-Fi an advanced automation system was developed to control the appliances in the house.

The controlling device for the automation in the project is an ARDUINO WIFI MODULE ESP8266. The data sent from Mobile over Cellular Data/Wi-Fi will be received by Wi-Fi module connected to ARDUINO WIFI MODULE ESP8266. ARDUINO WIFI MODULE ESP8266 reads the data and decides the switching action of electrical devices connected to it through Relays.

Blynk is a Platform with iOS and Android apps to control Arduino, Raspberry Pi and the likes over the Internet. It's a digital dashboard where you can build a graphic interface for your project by simply dragging and dropping widgets. It's really simple to set everything up.

Blynk is not tied to some specific board or shield. Instead, it's supporting hardware of your choice. Whether your Arduino or Raspberry Pi is linked to the Internet over Wi-Fi, Ethernet or this new ESP8266 chip, Blynk will get you online and ready for the Internet of Your Things.

2. METHODS & MATERIALS

2.1 EXISTING SYSTEM

In this system, user will enter fingerprint in the fingerprint scanner which is connected to the door latch through the microcontroller. After scanning the print, the system runs its database and looks for a match. If any match is found, the latch opens and thus, the door gets unlocked. Same thing happens when user wants to lock the door. Correct fingerprint makes the latch to close, locking the door behind the user.

If wrong fingerprint is given, the system beeps the buzzer showing "Try again" in the LCD displays. If consecutive 5 or more wrong fingerprints are given, i.e. if anyone tries to break in continuously, the system enters a secured mode where it rings the alarm showing "Panic Mode" on the LCD screen. A message gets delivered to the owner notifying that there has been an attempt to break in In this system, user will enter fingerprint in the fingerprint scanner which is connected to the door latch through the microcontroller. After scanning the print, the system runs its database and looks for a match. If any match is found, the latch opens and thus, the door gets unlocked. Same thing happens when user

wants to lock the door. Correct fingerprint makes the latch to close, locking the door behind the user.

If wrong fingerprint is given, the system beeps the buzzer showing "Try again" in the LCD display. If consecutive 5 or more wrong fingerprints are given, i.e. if anyone tries to break in continuously, the system enters a secured mode where it rings the alarm showing "Panic Mode" on the LCD screen. A message gets delivered to the owner notifying that there has been an attempt to break in this system, user will enter fingerprint in fingerprint scanner which is connected to the door latch or door lock through Arduino. After scanning the fingerprint, the system matches the pattern from the Primary Memory. If the match founds the Solenoid lock or latch will open.

If the detected fingerprint pattern happens to be wronged the system beeps the buzzer and enlights the Red LED.

A home automation system typically connects controlled devices to a gateway using Microcontroller (Arduino UNO, Raspberry pi, etc.). The user interface for control of the system uses either wall-mounted terminals and a mobile phone application, or a Web page, that may also be accessible offline through the Internet.

2.2 PROPOSED SYSTEM

The most important of feature of any home security system is to detect the people who enter or leave the house. Instead of monitoring that through passwords or pins unique faces can be made use of as they are one's biometric trait. These are innate and cannot be modified or stolen easily. The level of security can be raised by using face detection. The proposed face recognition door lock security system has been developed to prevent robbery in highly secure areas like home environment with lesser power consumption and more reliable standalone security device for both Intruder detection and for door security.

The proposed system is a distributed home automation system, consists of Arduino, micro controller, sensors and some electrical devices used in home. The Arduino controls and monitors the various sensors, and can be easily configured to handle more hardware interface module (sensors). Wi-Fi module is used to connect to the internet. Automation System can be accessed from the web browser of any local LAN using server IP, or remotely from any PC or device connected to the internet.

2.3 MATERIAL

1. Raspberry Pi
2. Electromagnetic Lock
3. Wires (Male to Male)
4. Camera
5. Node MCU ESP8266
6. Blynk Application
7. BreadBoard
8. LED, Fan and Sound
9. Relay Module
10. Wires (Male to Female)

Specification of Raspberry Pi

- **SoC:** Broadcom BCM2837
- **CPU:** 4x ARM Cortex -A53, 1.2GHz
- **GPU:** Broadcom VideoCore IV
- **RAM:** 1GB LPDDR2 (900 MHz)
- **Networking:** 10/100 Ethernet, 2.4GHz 802.11n wireless
- **Bluetooth:** Bluetooth 4.1 Classic, Bluetooth Low Energy
- **Storage:** microSD
- **GPIO:** 40-pin header, populated
- **Ports:** HDMI, 3.5mm analogue audio-video jack, 4x USB 2.0, Ethernet, Camera Serial Interface (CSI), Display Serial Interface (DSI)

Specification of ESP 8266

- Wi-Fi Direct (P2P), soft-AP.
- Integrated TCP/IP protocol stack.
- Integrated TR switch, balun, LNA, power amplifier and matching network.
- Integrated PLLs, regulators, DCXO and power management units.
- 19.5dBm output power in 802.11b mode.
- Power down leakage current of <10uA. 1MB Flash Memory.

- Integrated low power 32-bit CPU could be used as application processor.
- Standby power consumption of < 1.0mW (DTIM3).

WORKING of SYSTEM

A smart lock is an electromechanical lock which is designed to perform locking and unlocking operations on a door when it receives such instructions from an authorized device using a wireless protocol and a cryptographic key to execute the authorization process.

It also monitors access and sends alerts for the different events it monitors and some other critical events related to the status of the device. Smart locks can be considered part of a smart home.

Smart locks, like the traditional locks, need two main parts to work: the lock and the key. In the case of these electronic locks, the key is not a physical key but a Computer Device or Mobile Application or a special key for configured explicitly for this purpose which wirelessly performs the authentication needed to automatically unlock the door.

A home automation system will control lighting, entertainment systems, and appliances. It may also include home security such as access control and alarm systems.

When connected with the Internet, home devices are an important constituent of the Internet of Things. A home automation system typically connects controlled devices to a central hub or gateway.

The user interface for control of the system uses either wall-mounted terminals, tablet or desktop computers, a smart home application, or a Web interface, that may also be accessible off-site through the Internet.

Customers may hesitate to bet their IoT future on proprietary software or hardware devices that use proprietary protocols that may fade or become difficult to customize and interconnect.

4. BLOCK DIAGRAM

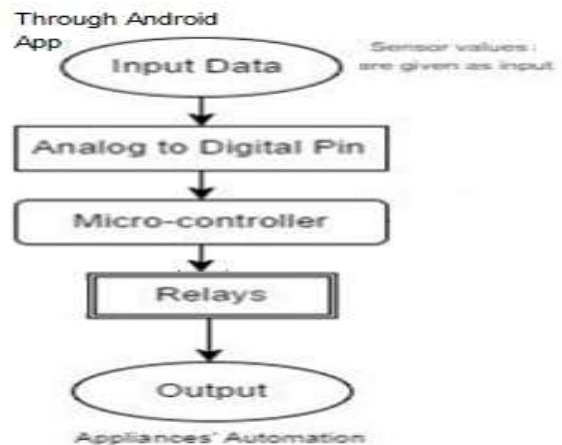
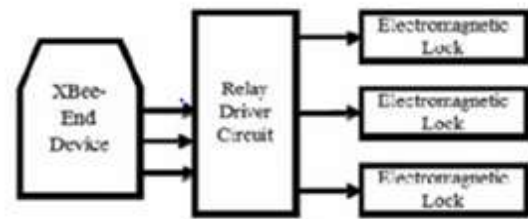
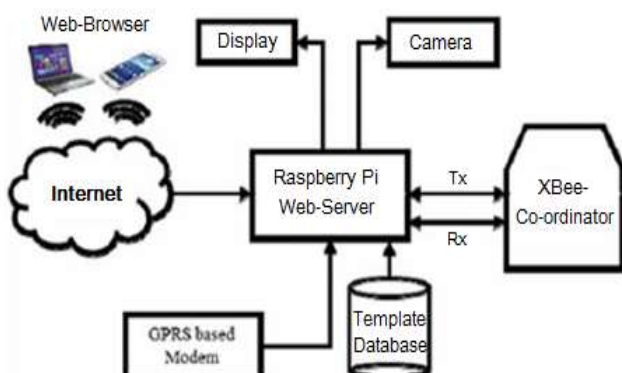

5. FUTURESCOPE

Using raspberry pi the current project can be modified by an Infrared camera interfacing it can be used in Smart Surveillance Monitoring security system which any type of public security is using Living body detection or spying, Also it can be used in Attendance system of the class, Also some profound applications can be implemented using interfacing of Raspberry pi and Arduino UNO board like sensor application of smartcard swapping, finger detection, alcohol detection, agriculture humidity sensing, Temperature sensing.

Future scope for the home automation systems involves making homes even smarter. Homes can be interfaced with sensors including motion sensors, light sensors and temperature sensors and provide automated toggling of devices based on conditions.

In future we can also add the automated System which can close the tape of gas pipeline as well as the water pipeline so that it will not remain on while user going out from his home, and for the security purpose we can add the password to the button in the mobile application so when the user or admin needs to turn ON or OFF the gas Pipeline and Water Pipeline then the application must pop up password window which shows that if the password is valid then only it will work if not valid then it won't work.

6. CONCLUSIONS

The arrangement of a facial recognition system using raspberry pi can make the system littler, lighter and work successfully utilizing lower control use, so it is the Computer-based face recognition system. Also, send a security alert message to the authorized person utilities.

Complete the face detection activity using python. We are going to use open cv library which is a package in python to develop the image detection System. The open cv library is mostly used in image processing techniques. The problem of how the motor will take the input and how it will perform the adjustment is solved by using a DAC which will convert the digital signal to analog signal as the motor only responds to the analog signal.

This operations of calculating and sending the signals will be done by the Raspberry Pi 3. Further work will be focused on how will the system handle the motors using Raspberry pi. The inputs taken from the image detection program should be able to coordinate properly with the motors. Further the quality of the image is an important factor of the system.

The screen will tilt on the basis on which part of the phase the users face is detected. A small module of the screen will be developed to test if the function and the system is working properly.

A Home Automation system integrates electrical devices in a house with each other. The techniques which are going to use in the home is the control of domestic activities, such as TV, fan, electric tubes and Sound. After studying and understanding literature survey and other existing works.

In this project, we are planning to eliminate most of the human interaction by providing the intelligent system. Development of such Smart Home achieves by using the Internet of Things technologies. By using this system, we can actually manage to make low cost, flexible smart home Automation to adjust its environmental conditions and resolve its errors with energy saving

REFERENCES

- [1] "Your Door Is About to Get Clever: 5 Smart Locks Compared". Wired. 2013-06-19.
- [2] "Goji's Smart Lock snaps pictures, welcomes you by name". Engadget. 2013-06-04.
- [3] "Smart Locks, Secure or Just Dumb?". Gizmodo. 2013-06-05
- [4] Rye, Dave (October 1999). "My Life at X10". AV and Automation Industry eMagazine. AV and Automation Industry eMagazine. Archived from the original on September 30, 2014. Retrieved October 8, 2014.
- [5] "1.5 Million Home Automation Systems Installed in the US This Year". www.abiresearch.com. Retrieved 2016-11-22.
- [6] <https://www.statista.com/outlook/279/109/smart-home/united-states#market-users>
- [7] <https://www.forbes.com/sites/forbesagencycouncil/2018/09/24/the-impact-of-the-digital-revolution-on-the-smart-home-industry/#74f76a1e3c76>
- [8] Li, Rita Yi Man; Li, Herru Ching Yu; Mak, Cho Kei; Tang, Tony Beiqi (2016). "Sustainable Smart Home and Home Automation: Big Data Analytics Approach" (PDF). International Journal of Smart Home. 10 (8): 177–198. doi:10.14257/ijsh.2016.10.8.18.
- [9] Asadullah, Muhammad (22 Dec 2016). "An Overview of Home Automation Systems". Conference Paper. IEEE. Retrieved 22 Dec 2016.
- [10] "Home", Blynk. [Online]. Available: <http://www.blynk.cc/>. [Accessed: 23-May-2016].
- [11] LPaduel, "Loadshedding Schedule," Nepal Electricity Authority. [Online]. Available: <http://nea.org.np/loadshedding.html>. [Accessed: 16-May- 2016].