

# Wireless Sensor Network for Railway Security System

Monali S. Chakdhare<sup>1</sup>, Akash M. Ghangale<sup>2</sup>, V. P. Athawale<sup>3</sup>

<sup>1,2</sup>Student, Dept. of Electrical Engineering, DES'S COET, Dhamangaon Rly

<sup>3</sup>Professor, Dept. of Electrical Engineering, DES'S COET, Dhamangaon Rly

\*\*\*

**Abstract** - Railways comprise a large infrastructure and are an important mode of transportation in many countries. The railways have become a new means of transportation owing to their capacity, speed, and reliability, being closely associated with passenger and goods transportation; they have high risk associated with them in terms of human lives and cost of assets. In this review, several wireless sensor networks (WSNs) applications are proposed for use in railway station systems, including advanced WSNs, which will enhance security, safety, and decision-making processes to achieve more cost-effective management in railway stations, as well as the development of integrated systems. The size, efficiency, and cost of WSNs are influential factors that attract the railway industry to adopt these devices in this paper, different kinds of rail defects inspection and maintenance methods are described and a basic algorithm is readdressed that makes use of wireless acoustic sensors for detecting cracks and breakages in the railway tracks.

**Key Words:** Railway Security, Cracks detection, Wireless sensor networks.

## 1. INTRODUCTION

The WSN technology perspective of the rail infrastructure will be vital to the railway industry's future expansion, and will enhance other areas in industry such as safety and security towards a more intelligent infrastructure [3]. A WSN is a system formed by many sensor points where each node is equipped with a sensor. Wireless sensor networks are seen as an innovative information gathering technique to design the information and communication system, which will significantly advance the reliability and efficiency of the systems in the railway station. Compared with a wired solution, WSN systems are easier for positioning and have better elasticity. Furthermore, with the prompt industrial growth of sensors, WSNs will become the most significant technology for the internet of things (IoT).

The life of a bridge is not dictated by its age but rather by its physical state to identify and expedite the maintenance of its bridges. Indian railways has a system to mark bridges needing immediate rebuilding or rehabilitation as 'distressed bridges'. The main technical and scientific objectives of our system in this paper are to generate innovative solutions for a number of the issues facing the railroad community through development of a system based on WSN. The objectives from a railroad perspective include finding new approaches to reduce the occurrence rate of accidents and improving the efficiency of railroad maintenance activities.

A wireless sensor network (WSN) is a wireless network consisting of spatially distributed autonomous devices that use sensors to monitor physical or environmental conditions. These autonomous devices, or nodes, combine with routers and a gateway to create a typical WSN system. The distributed measurement nodes communicate wirelessly to a central gateway, which provides a connection to the wired world where you can collect, process, analyze, and present your measurement data. To extend distance and reliability in a wireless sensor network, you can use routers to gain an additional communication link between end nodes and the gateway.

Currently, wireless sensor networks are beginning to be deployed at an accelerated pace. It is not unreasonable to expect that in 10-15 years that the world will be covered with wireless sensor networks with access to them via the Internet. The major challenges to be addressed in WSNs are coverage and deployment, scalability, quality-of-service, size, computational power, energy efficiency and security.

Undoubtedly, railway stations are a significant component for communication with the drivers, controlling and managing emergency situations, and aiding in daily operations such as those involving train engineers' safety and security operations. Recently, railway infrastructure has expanded rapidly, including the use of wired communication systems. Previously, wired connecting systems were utilised for signalling and data intelligence in the railway system.

Among these challenges, security is a major issue in wireless sensor networks. Most of the threats and attacks against security in wireless networks are almost similar to their wired counterparts while some are exacerbated with the inclusion of wireless connectivity. In fact, wireless networks are usually more vulnerable to various security threats as the unguided transmission medium is more susceptible to security attacks than those of the guided transmission medium.

The broadcast nature of the wireless communication is a simple candidate for eavesdropping. In this paper we present an overview of the applications and security issues relating to Wireless Sensor Networks (WSNs). This can be considered as the Internet becoming a physical network. This new technology is exciting with unlimited potential for numerous application areas including environmental, medical, military, transportation, entertainment, crisis management, homeland defense, and smart spaces.

## 2. RELATED WORK

For Track surveying with sensors the authors have proposed an architecture which has sensor nodes deployed along a railway track as shown in Fig.2.2. The network consists of numerous control centers (sink nodes) that are connected through a wire lined connection, and the sensor nodes are deployed along the railway lines. The sensor nodes collect the necessary data and forward the data back to the sink. An innovative railway track surveying procedure is described that uses sensors and simple components like a GPS module, GSM Modem and MEMS based track detector assembly. The surveying system proposed in this seminar can be used for both ballast and slab tracks. The railway geometrical parameters which are Track axis coordinates are obtained with integrated Global Positioning System (GPS) and Global System for Mobile communication (GSM) receivers. The authors have proposed a cheap, and simple scheme with sufficient ruggedness which is suitable in the Indian scenario that uses an LVDT arrangement to survey track geometry by using multi sensor, which has proved to be cost effective as compared to the existing methods. This sensor very accurate detection and it will send information immediately by using GSM. The system can be operated in tunnels without interruption.

### 2.1: Advantages

- i) **Flexible:** WSN is a flexible network and can adapt to the changes.
- ii) **Additional of New Device:** WSN can accommodate new devices in the network any time with ease.
- iii) **Save Cost:** Wireless sensor networks save a lot of wiring cost and sensors like PIR detectors are relatively cheaper than wires.
- iv) **Useful to society:** Wireless sensor network are used in different fields like healthcare, defense, environment monitoring which is very beneficial to human welfare.
- v) Network setups can be carried out without fixed infrastructure.
- vi) Suitable for the non-reachable places such as over the sea, mountains, rural areas or deep forests.
- vii) Flexible if there is random situation when additional workstation is needed.
- viii) Implementation pricing is cheap.
- ix) It avoids plenty of wiring.
- x) It might accommodate new devices at any time.
- xi) It's flexible to undergo physical partitions.
- xii) It can be accessed by using a centralized monitor.

### 2.2: Disadvantage

- i) **Security:** WSN networks are not secure as compared to wired networks. Hackers can easily hack the network.
- ii) **Battery Issue:** Nodes need to be charged at regular intervals. Battery life of the nodes is very low.

- iii) **Low Communication Speed:** Communication speed is comparatively low than the wired network.
- iv) **Distraction:** Wireless sensor networks keep distracting by other wireless devices.
- v) Easily troubled by surroundings (walls, microwave, large distances due to signal attenuation, etc).
- vi) It is easy for hackers to hack it we couldn't control propagation of waves.
- vii) Comparatively low speed of communication.
- viii) Gets distracted by various elements like Blue-tooth.
- ix) Still Costly (most importantly)
- x) Less secure because hackers can enter the access point and obtain all the information.
- xi) Lower speed as compared to a wired network.
- xii) More complicated to configure compared to a wired network.

## 2.3: Applications

### a) Military or Border Surveillance Applications

WSNs are becoming an integral part of military command, control communication and intelligence systems. Sensors can be deployed in a battle field to monitor the presence of forces and vehicles, and track their movements, enabling close surveillance of opposing forces.

### b) Environmental Applications

Environmental applications include tracking the movements and patterns of insects, birds or small animals.

### c) Health Care Applications

Wireless sensor networks can be used to monitor and track elders and patients for health care purposes, which can significantly relieve the severe shortage of health care personnel and reduce the health care expenditures in the current health care systems. For example sensors can be deployed in a patient's home to monitor the behaviors of the patient. It can alert doctors when the patient falls and requires immediate medical attention.

### d) Environmental Conditions Monitoring

WSN applications in this area include monitoring the environmental conditions affecting crops or livestock, monitoring temperature, humidity and lighting in office buildings, and so on. These monitoring modules could even be combined with actuator modules which can control, for example, the amount of fertilizer in the soil, or the amount of cooling or heating in a building, based on distributed sensor measurements.

### e) Home Intelligence

Wireless sensor networks can be used to provide more convenient and intelligent living environments for human beings. For example, wireless sensors can be used to

remotely read utility meters in a home like water, gas, electricity and then send the readings to a remote center through wireless communication.

#### f) Industrial Process Control

In industry, WSNs can be used to monitor manufacturing process or the condition of manufacturing equipment. For example, chemical plants or oil refiners cause sensors to monitor the condition of their miles of pipelines. These sensors are used to alert in case of any failures occurred.

#### g) Agriculture

Using wireless sensor networks within the agricultural industry is increasingly common; using a wireless network frees the farmer from the maintenance of wiring in a difficult environment. Gravity feed water systems can be monitored using pressure transmitters to monitor water tank levels, pumps can be controlled using wireless input devices and water use can be measured and wirelessly transmitted back to a central control center for billing. Irrigation automation enables more efficient water use and reduces waste.

#### h) Structural Monitoring

Wireless sensors can be used to monitor the movement within buildings and infrastructure such as bridges, flyovers, embankments, tunnels etc. enabling Engineering practices to monitor assets remotely without the need for costly site visits, as well as having the advantage of daily data, whereas traditionally this data was collected weekly or monthly, using physical site visits, involving either road or rail closure in some cases. It is also far more accurate than any visual inspection that would be carried out.

### 3. METHODOLOGY

#### 3.1 Wireless Sensor Network for Railway Condition Monitoring

Sensor devices are mounted on boards attached to the object being monitored, for examples include track, bridges, or train mechanics. One or more sensors are mounted on a sensor board (node). The sensor nodes communicate with the base station using a wireless transmission protocol; examples include Bluetooth and Wi-Fi. The base station collates data and transmits it to the control center server possibly through satellite or GPRS. There are variations on this setup. In some systems, the sensor nodes may communicate directly with the server rather than via the base station. In other systems, the user accesses the data directly via the base station.

Plastic approach may lead to a large number of false alarms and missed failures. It only provides local analysis but does not take advantage of the superior capabilities when the sensors are networked and their data processed

collectively. Integrated data processing allows an overall picture of an asset's condition to be achieved and overall condition trends to be determined. In recent years, networking technologies such as wireless communication and mobile networking coupled with the technology to integrate devices have rapidly developed.

There are a number of challenges with WSNs. They generate large amounts of data at rapid rates and often on an basis. Data may be produced from multisource that have to be fused. The systems and structures monitored using sensors often exhibit complex behavior, which is difficult to understand and interpret. Hence, the data must be carefully managed to provide a view of the system status. Sensor data are very noisy and sensors themselves can become defective wherever they are installed. Sensor data may contain errors, particularly where the sensors are subject to harsh conditions as this exacerbates sensor and communication failures. Sensor networks often have to be installed in challenging environments to be able to monitor structures and infrastructure.

For example, Palo noted that their system had to work in extreme conditions in Sweden, with a temperature range between +25°C and -40°C and with large quantities of snow mounted sensors on the train's bogies to monitor bogie temperatures and noted that train environments are very harsh environments for electronics with high accelerations and large shocks. The sensors need to be carefully located to ensure their measurements are useful and do not replicate the measurements of other sensors, which can skew the distribution of the collected data. The type of sensor used needs to be carefully considered to ensure the maximum value and the best quality data. WSNs can use a set of homogeneous or heterogeneous sensors. Sensors are often located away from energy supplies, thus require either batteries or some form of local energy generation to power them. If there are errors in transmission across the WSN, then data may be missing. These last two points form a paradox, WSNs need to minimize energy usage yet communication needs to be maximally efficient and communication requires energy. This survey seminar describes WSNs for railway condition monitoring focusing on systems described in the academic literature. In this survey, "sensor" refers to an individual device such as an accelerometer or strain gauge.

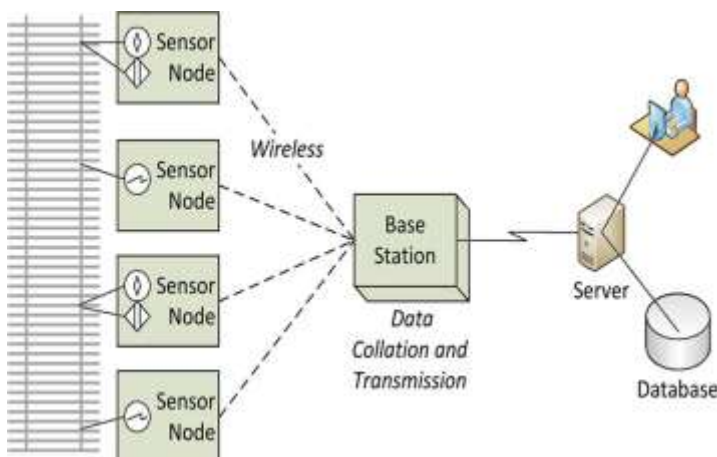

Fig. 3.1: WSN Setup for Railway Condition Monitoring

#### 4. CONCLUSION

The main aims of the critical review are to identify the enhanced security and safety in railway stations and present an innovative way for smart railway stations to use the big data gathered from WSNs. The size, efficiency, real-time condition, improved safety, security, and reliability and cost of wireless sensors are factors that attract the railway industry to the use of WSN technology. The sensor nodes are equipped with sensors that can sense the vibration in the railway track due a coming train. The geographical positioning sensors are placed on the trains. These sensors send the train's geographic location. Optimization of the communication protocol and real time working network with minimum delay in multi hop routing from the nodes to the train using a static base station is needed, so that the decision making can be done and the decision is forwarded to the train without any delay.

#### REFERENCES

- [1] V. Reddy, "Deployment of an integrated model for assessment of operational risk in railway track", Master Thesis, Queensland University of Technology School of Engineering Systems, 2007.
- [2] C. Esveld, "Modern railway Track". Second Edition, MRT Productions. 2001.
- [3] D.Hesse "Rail inspection using ultrasonic surface waves" Thesis ,Imperial College of London,2007
- [4] C. Campos-Castellanos, Y.Gharaibeh, P. Mudge \*, V. Kappatos, "The application of long range ultrasonic testing (LRUT) for examination of hard to access areas on railway tracks". IEEE Railway Condition Monitoring and Non-Destructive Testing (RCM 2011) Nov 2011.
- [5] W. Al-Nuaimy , A. Eriksen and J. Gasgoyne " Train-mounted gpr for high-speed rail trackbed inspection" Tenth International Conference on Ground Penetrating Radal; 21 -24 June, 2004

- [6] A.Vanimiredd, D.A.Kumari "Automatic broken track detection using LED-LDR assembly" International Journal of Engineering Trends and Technology (IJETT) - Volume4 Issue7- July 2013
- [7] Hayre, Harbhajan S., "Automatic Railroad Track Inspection," Industry Applications, IEEE Transactions on, vol.IA-10, no.3, pp.380,384, May 1974.
- [8] Z. Sam Daliri<sup>1</sup>, S. Shamshirband , M.A. Besheli " Railway security through the use of wireless sensor networks based on fuzzy logic". International Journal of the Physical SciencesVol. 6(3), pp. 448-458, 4 February,2011
- [9] S. Ramesh, S. Gobinathan "Railway faults tolerance techniques using wireless sensor networks". IJECT Vol. 3, Issue 1, Jan. - March 2012.
- [10] A. Z Lorestani, S. A Mousavi, R. Ebadaty, "Monitoring RailTraffic Using Wireless Sensor Network (WSN)" IJCSET ,June 2012, Vol 2, Issue 6,1280-1282
- [11] Aboelela, E. Edberg, W. Papakonstantinou, C. Vokkarane, V, "Wireless sensoer network based model for secure railway opeations," Performance, Computing, and Communications Conference, 2006. IPCCC 2006. 25th IEEE International, vol., no., pp.6 pp., 628, 10-12 April 2006.