

# Design and Development of Automatic External Pipe Climber

Suraj Kontamwar<sup>1</sup>, Vivek Mishra<sup>2</sup>, Sourabh Smarth<sup>3</sup>, Bhushan Sonwane<sup>4</sup>, Shahbaz Khan<sup>5</sup>, Prof. A.B. Amale<sup>6</sup>

<sup>1-5</sup>Mechanical Engineering, Yeshwantrao Chavan College of Engineering, Nagpur

<sup>6</sup>Professor, Mechanical Engineering, Yeshwantrao Chavan College of Engineering, Nagpur.

\*\*\*

**ABSTRACT:** This project describes the concept, design and prototype implementation of a wheeled pole-climbing-robot based on Ferromagnetic adhesion. Pole climbing robots have become an interesting area for research in the last years. Several robots have been developed to solve this given problem. Every construction has its own advantages and disadvantages. The goal of this work was to design another pole climbing robot that uses a ferromagnetic adhesion principle. It was not the forceful goal to create a fully optimized working robot but rather to learn the design and construction steps, which are needed for a new product from the engineering point of view.

**KEYWORDS:** Wall Climbing Robot, Magnetic Adhesion, Adhesion-Locomotion, Surface Inspection, Pipe Robot.

## INTRODUCTION

Inspection and maintenance are essential in all industries. Failure to conduct proper maintenance could result in potential danger to workers and machines. Carrying out these inspections impose rigorous hurdles in case of various industries where the conditions are unsafe for human workers, for example, inspection and maintenance in a nuclear industry, where the environment poses serious risk for the humans. The most common way for conducting these inspections in hazardous conditions is to use long manipulators which could be expensive. The alternate way of carrying these inspections is by using walking/climbing robots on a pipe.

Pipe climbing robots are advanced robots, which have the potential to climb outside of a pipe to perform specific functions, where a normal operator cannot be used. The improvements in this sector have grown rapidly, since it's a cheap and effective way for investigating various leakages in a pipe.

Gas and oil tanks, wind turbines, pipelines and marine vessels are examples of the structures which are the target for the application of the ferromagnetic pipe climbing robot. Such structures are usually built from ferromagnetic material having a convex circumference and thus, utilization of magnetic adherence systems is a natural choice. Pole climbing robots received increasing attention during the previous years due to their application in the inspection of pipelines and similar structures. In order to hold itself to a smooth surface, the climbing robot can use suction cups, gripping mechanism and magnetic adhesive. In this project, we are using a magnetic adhesive type.

### A. Problem Statement

It was observed that to inspect the vessel was difficult for humans, so it was a required a

system which can inspect the leakage part of the vessel which was impossible due to hazardous gases and risky situations. So, magnetic climbing robot was designed for that purpose.

### B. Objectives

1. Development of robot climbing using locomotive mechanism.
2. Automatic controlling of Robot using Arduino controller.
3. Provide Real time image using Camera.

## METHODOLOGY

### • Mechanical design

In this mechanical design, it includes the conceptual design of the robot, fabrication and finally assembly process.

This robot Structure is made of ABS (Acrylonitrile Butadiene Styrene) plastic. This robot consist of three BO motor that have less rpm but higher torque and magnetic adhesion which is enough for gripping the poles or pipes gas vessels, oil tanks etc.

### • Motor Selection

In this work, DC motor with high torque has been chosen as a climbing module and gripping module because it having higher torque and easy to control.

- Magnet selection

Neodymium Iron Boron (NdFeB) magnet is a permanent magnet composed of rare earth magnetic material and has a high coercive force.

### WORKING

This robot works on principal of ferromagnetic adhesion in which the robot can stuck on the ferromagnetic surfaces and can move along the surfaces for inspection of the surface using cameras.

The robot consist of 3 wheels which help the robot climb on the surfaces. The ferromagnetic pipe climbing robot being designed for this project uses magnets to keep itself attached to the pipe while the motors and wheels system help to move the robot in the vertical or horizontal direction by applying torque. DC motors are used as they provide 360 Degree of rotation for the wheels. The entire design and fabrication will be done while keeping in mind that the weight of the robot needs to be as low as possible.

Giving Magnetic Adhesion properties to the robot can be achieved by Permanent Magnets as well as Electro Magnet. But using an Electro Magnet was not an option due to its huge power consumption which would lead to heavy weight batteries and end up making the overall robot so heavy that it would not be able to stick to Iron Surface or ferromagnetic surfaces. The rpm will be less but the torque will be more so that it can push the robot to climb on pipes.

### DESIGN CALCULATION AND CAD MODELING

Static force analysis:

When the robot remains constant on verticle surface

Let,

G= gravity

F(m)= Force generated by magnetic units;  
N(i)=supporting force of the surface; F(f)= friction force.

There are three cases for static force analysis If robot maintains static positon then

$$F(m)=N(i)$$

Slipping down from the wall.

The robot staying on the surface will slip down if force of attraction is small.

To overcome this problem the friction force must begreater than the gravitational force.

Taking frictional force double than the gravitational

force.

$$\text{i.e } 2F(f) \geq G \text{ (A)}$$

if the friction coefficient is  $\mu$  therefore,

$$F(f)=\mu F(m) \text{ From equation A } 2\mu F(m) \geq G$$

$$\text{i.e } F(m)=G/2\mu$$

Wheels rotating on the wall: Here,

M(b)= break torque

M(t)= torque transmitted by the motors

Considering a point on the wall where robot will be rotating

Therefore torque at a point B is given by  $M(B)=M(b)+M(t)+F(m) \times a - GH/2=0$

$$\text{i.e } M(b) + M(t) + F(m) \times a = GH/2 \quad M(b) + M(t) = GH/2 - F(m) \times a \text{ (B)}$$

Where,

A= distance between N(i) and F(m) **2 .Dynamic Force Analysis** 1.Robot climbing Upwards

When the robot moves upwards ,the torque you provided by the motors M(d) should be large enough to drive the wheels

Therefore

$$M(d) - F(m) \times a - GH/2 = 0 \text{ ©}$$

$$\text{I e. } M(d) = F(m) \times a + GH/2$$

2. Robot crawling downwards When robot tries to get downwards  $M(t) + F(m) \times a + M(d) - GH/2 = 0$

I.e

$$M(d) = GH/2 - M(t) - F(m) \times a \dots\dots (d)$$

Here M(t)= torque transmitted by the motors

Froma (A) , (B) and c and D

$$M_b \geq GH/2 - F(m) \times a \quad M(d) \geq \max\{(GH/2 - M(t) - F(m) \times a), (F(m) \times a + GH/2)\} \dots\dots$$

$$M_b \geq GH/2 - F(m) \times a \quad M(d) \geq \max\{(GH/2 - M(t) - F(m) \times a), (F(m) \times a + GH/2)\} \dots\dots$$

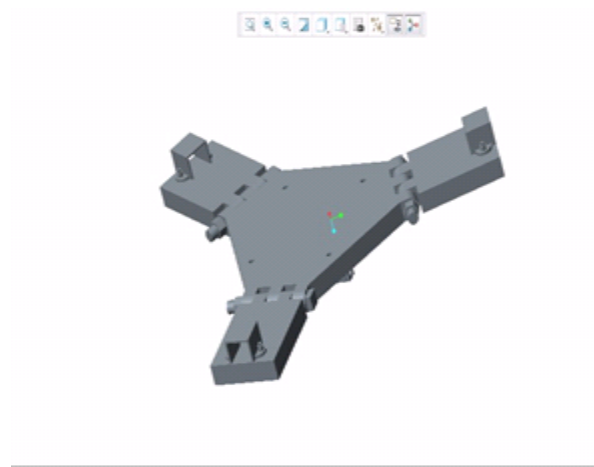
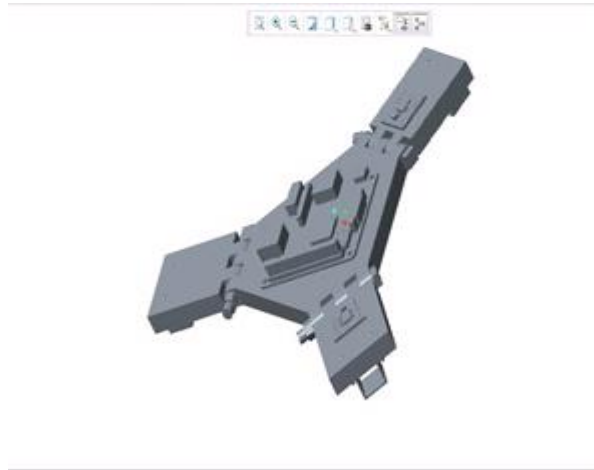

**COMPONENTS SETUP**

SR. NO.	COMPONENTS	SPECIFICATION	QUANTITY
1.	Arduino Board	—	1
2.	Pi-Camera Module	—	1

3.	Sd Card	Up to 16 GB	1
4.	Li-ion Battery	3.7V,1500 mah	2
5.	White Led	—	1
6.	BO Motor	60rpm, high torque low speed	3
7.	Motor Wheel	Rubber Hollow	3
8.	Neodymium Magnet	—	100
9.	Wire	—	5m
10.	Soldering wire	—	—
11.	Solder	—	—
12.	Screws and Nuts	—	—

### CONCLUSIONS

- We developed a climbing robot using magnetic adhesion principle.
- The motion of the robot was controlled by Arduino controller which has microcontroller that allows the logical operations to be performed.
- The climbing operations of the Robot has permanent magnets which create magnetic force based on which it provide adhesive force to robot to stick on vertical surface.
- The camera sensor will help us to externally inspection of pipe.
- Hardware and software are integrated in a way to provide imaging-based automatic inspection and analysis for such applications as automatic inspection, and robot guidance.

### FUTURE SCOPE

- The wall climbing robot is one kind of the special robots. Because the workspace of this kind of robots is often on the vertical plane, not only does the wall climbing robot need to have the same locomotion mechanism as mobile robots.
- It also needs the special adhesion mechanism to support it to absorb on the vertical walls.

Therefore, it is more challenging to develop a wall climbing robot that a mobile robot.

- To increase operation efficiency and protect human's health and safety in hazardous tasks makes the wall climbing robot very attractive.

The climbing robot is widely applied in different industrial departments, such as the inspection and maintenance of storage tanks in nuclear power plants and petrochemical enterprises, ship hull welding and cleaning, rescue robots for fire fighting, the cleaning of high- rise buildings, etc.

### References

- Laboratoire des Sciences du Numerique de Nantes LS2N, Ecole Centrale de Nantes (2018).
- Riad Hossain Faisal, Nafiz Ahmed Chisty "Design and Implementation of a wall climbing robot" International Journal of Computer Applications (2018).
- Ravindra Singh Bisht "Experimental investigations on permanent magnet based wheel mechanism for safe navigation of climbing robot" International Conference on Robotics and Smart Manufacturing (RoSMa2018).
- Bing Li, Kenshin Ushiroda "Wall- climbing robot for non-destructive evaluation using impact-echo and metric learning SVM" (2017). [5] Arnab kumar Das on "Ferromagnetic-Pipe-Climbing Robot" (2019)

- 2) Yanwei Liu, Gaowei Liu "Design and Experiment of a Bioinspired Wall-Climbing Robot Using Spiny Grippers" International Conference on Mechatronic and Automation (2016).
- 3) MD Omar Faruq Howlader "Finite Element Analysis based Optimization of Magnetic Adhesion Module for Concrete Wall Climbing Robot" International Journal of Advanced Computer Science and Applications (2015).
- 4) Mohamed G Alkalla "Versatile Climbing Robot for Vessels Inspection" International Conference on control, Automation and Robotics (2015).
- 5) "Design and Fabrication of Pipe Line Climbing Robot", International Journal of Scientific and Engineering Research, Volume 5, Issue 7, July-2014.
- 6) Ke Wang, Rong Liu "Development of a Double-Cavity Climbing Robot for On-Site Inspection of Glass-Curtain-Walls" International Conference on Information and Automation.
- 7) Mahmoud Tavakoli "Omni Climbers: Omni-directional magnetic wheeled climbing robots for inspection of ferromagnetic structures" (2013).
- 8) Weiguang Dong, "Design and Analysis of a Novel Wall-Climbing Robot Mechanism" (2011).
- 9) A. Albagul, "Wall Climbing Robot: Mechanical Design and Implementation" (2011).
- 10) Surachai Panich, "Development of a Wall Climbing Robot" International Journal of Computer Science, (2010).
- 11) <http://www.mnre.gov.in/>