

Automatic Control of Power with Energy Saving through Sensor in Smart Home Appliances

Amisha S. Patil¹, Punam M. Hude², Prayoshni D. Dere³, Dipali G. Lawankar⁴, Shubhangi R. Ingle⁵, Kirti B. Nagne⁶

¹⁻⁵Student, Dept. of Electrical Engineering, DES'S COET, Dhamangaon Rly

⁶Professor, Dept. of Electrical Engineering, DES'S COET, Dhamangaon Rly

Abstract - Fan speed is controlled by changing the voltage level across them using triacs which avoids the losses of potentiometer regulators. Many times we leave the room and hall without switching off lights and fans, thus electricity is wasted. If it is six degrees or more below the threshold the fans are turned off. If the natural light intensity is below the preset threshold value then the lights are turned on and vice versa. Room temperature readings are taken from an sensor and compared with the user defined threshold value. This system saves energy by efficient power management of a room which employs certain controlling mechanisms managed by a microcontroller. The mechanisms include light control relative to the natural light intensity in the room, fan control relative to the room temperature and motion detection for determining absence of occupants in the room. Motion detection is achieved by using a sensor. The system reads light intensity level from an voltage divider circuit. At intermediate temperatures the fans run at intermediate speeds. If the readings are above or equal to the threshold value then the fans run at full speed. Lastly, the user defined thresholds are changed using a keypad. If the room stays unoccupied for a preset amount of time the loads are turned off to prevent wastage.

input main voltage of 220v to a variable voltage within 220v to 170v, is used to control a large lighting network and dimming is used to control light intensity. Reference constructed a wireless security control systems & sensor network for smoke and fire detection. They used a smoke detector device that detects smoke & issues an alarm to alert nearby people.

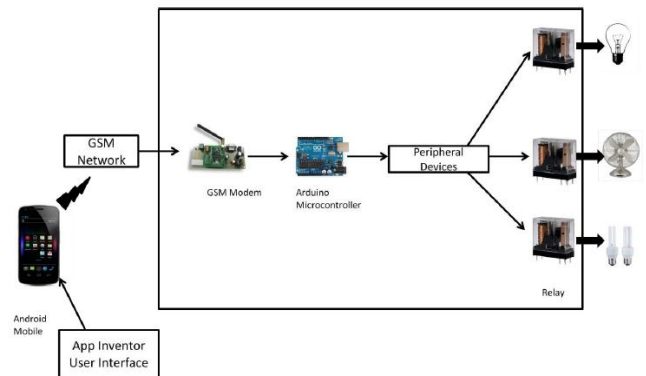

Fig.1.1: Overview of Smart Home Automation

Key Words: Energy Saving, LDR, Lm35, Microcontroller, Motion Sensor, PIR.

1. INTRODUCTION

Electricity is one of earthshaking resources in this century. It is the major source of power for most of the country's economic activities. Moving towards energy sustainability will require modifications not only in the way energy is supplied, but also in the way it is used as well. Many times we do not turn off the light or fan at the time of deserting the room, thus electricity is wasted. By raising public awareness we can reduce the wastage of electricity. But it is not enforced due to carelessness. In this case we can use home automation system. Home automation is the automatic or semi-automatic control and monitoring of household appliance and residential home features like doors, gate & even the windows.

Automatic control refers to any controlling mechanism which does not require any human intervention. In order to save energy Wei Yan and S.Y.R Hui built a system, which has a central energy saving unit that can change the

Automatic Room light and fan Controller with Visitor Counter can be used in class rooms, study rooms in colleges. When people come to that area, according to the LDR output lighting can be made sufficiently brighter. This work can also be used in our home because many times we come out of our bedroom or any other room without turning off the room light. This work can be used in various rooms like seminar hall, conference hall where the capacity of room is limited and should not be exceeded. At the same time when people are not present in the monitored area the lighting can be made off. By using this system, we can also fine-tune the speed of the Fan depending on the room temperature measured by the temperature sensor. This system also serves us to know about the number of visitors in the monitored area such as a room or office. The objective of our proposed system is to save the energy or power, used in places like an office or room where the lighting is very essential for the people. It is used only when one single person cuts the rays of the sensor hence it cannot be used when two person cross simultaneously. A smoke sensor module is used for detecting any smoke within the room and provides an alert by the audio alarming device. This work will display the actual number of persons inside the room.

2. RELATED WORK

Earlier home automation systems like the X10 system combined the signaling network with the power grid. However, the downside is that the switching unit keeps consuming energy as long as it stays on. INSTEON technology is a dual-band mesh topology employing AC-power lines and a radio-frequency (RF) protocol to communicate with and automate home electronic devices and appliances, which normally work independently. Instead, switching is done electronically (automatically). This means that the inner device is separated from the switching circuit. According to a Popular Mechanics magazine article, INSTEON is not only "an effective system for connecting lighting switches and loads without extra wiring, but it also forms the basis for a more sophisticated home automation network."

However, power-line based systems have inherent problems like radio interference, security flaws and reliability issues which have never been solved completely. The function of the switch on the wall or even in the device is taken over by a network which is solely for signaling events. Some appliances include USB that is used to control it and connect it to a domotics network. However, sensing of occupants and detection of day/night are not incorporated in INSTEON. from X10 to European Installation Bus). The changing paradigm in home automation is also that a device is no longer disconnected from the power grid. The earliest instance of a pure datagram based network standard for building automation is the European Installation Bus (EIB) standard implemented in 1992. This technology which is power-line based has regained popularity recently as an alternative to Digital Subscriber Line (DSL) technology which requires dedicated signaling cables like telephone lines. All INSTEON devices are peers, meaning each device can transmit, receive, and repeat any message of the INSTEON protocol, without requiring a master controller or complex routing software. Bridges translate information from one standard to another (e.g. The network which controls devices by transmitting datagrams is powered with a much lower current. Some computer main boards even allow reaction to power network events. Specific domestic wiring and communication standards include BACnet, INSTEON, X10, PLC BUS, KNX (standard), System Box, LonWorks, CBus, SCS BUS with OpenWebNet, Universal Powerline Bus (UPB), UPnP, ZigBee and Z-Wave that will allow for control of most applications. INSTEON is designed to enable simple devices to be networked together using the power-line and/or radio frequency (RF). Control wiring is hardest to retrofit into an existing house. INSTEON was developed, based on the X10 model, for control and sensing applications in the home.

It is a home automation networking technology invented by SmartLabs, Inc. Some standards use communication and control wiring, some embed signals in the power line, some use radio frequency (RF) signals, and some use a combination of several methods. Since the

beginning of electrification, switching electrical devices has been done by means of connecting or disconnecting them to the power grid. In recent years, physically disconnecting a device from its energy source has become less popular. As a consequence, the device can be powered on or off by a remote control or in the case of this research work by an automated switching panel based on the number of persons occupying a room.

3. METHODOLOGY

3.1 Block Diagram of Proposed System

The design demonstrates here, has 3 modules. The first module is "Visitor counter", the second module is "Automatic room light and fan controller" and the third is "Safety unit". Visitor counter is used to determine and display the number of persons entering in and getting out from any room like seminar hall, conference room etc. The automatic room light and fan controller is used to turn ON/OFF the home appliance. When the number of persons within the room is zero, light and fan stays OFF. When persons are present, the light and fan made ON, where light intensity and speed of the fan are controlled by sensors. As a Safety unit a smoke sensor module is used for detecting any smoke within the room and provides an alert by the audio alarming device. LCD display positioned outside the room which shows the number of people within the room. We show the block diagram of our work in Fig Here we draw on five circuits as input of a microcontroller (MCU) and four circuits as output.

The input circuits are:

- (i) Bidirectional Counters
- (ii) LDR
- (iii) Temperature Sensor
- (iv) Zero Crossing Detector
- (v) Smoke Sensor

The output circuits are

- (i) LCD display
- (ii) Lamp
- (iii) Fan
- (iv) Audio Device.

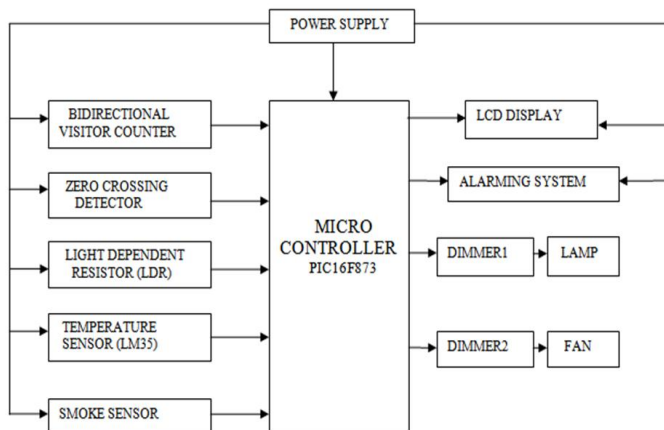

Fig.3.1 Block Diagram of Automatic Energy Saving in Home Automation

If a person enters in the monitored area, the IR sensors of visitor counter will activate and sense the person. By sensing the person, the counter sends a signal to the micro controller. After that the LDR [14] checks the light intensity of the monitored area, whether it is bright or dark. LDR output will settle on the ON or OFF status of the lamp. We can also regulate light intensity depending on the brightness of the monitored area. By using this system we can change the speed of Fan according to the room temperature calculated by the temperature sensor LM35, which are connected to the microcontroller. Also to show the room temperature using the LCD display. This system does not save power but it is comfortable for human being. A smoke sensor module is used for detecting smoke within the room and provides an alert by the audio alarming device.

3.2 Automated room light and fan controller

The automatic room light and fan controller is used to turn ON/OFF the home appliance. When the number of persons within the room is zero, light and fan stays OFF. When they are present, the light and fan made ON, where light intensity and speed of the fan are controlled by sensors. The heart of our automation system is a microcontroller, which is configured by programming in the Micro C Pro, an advanced.

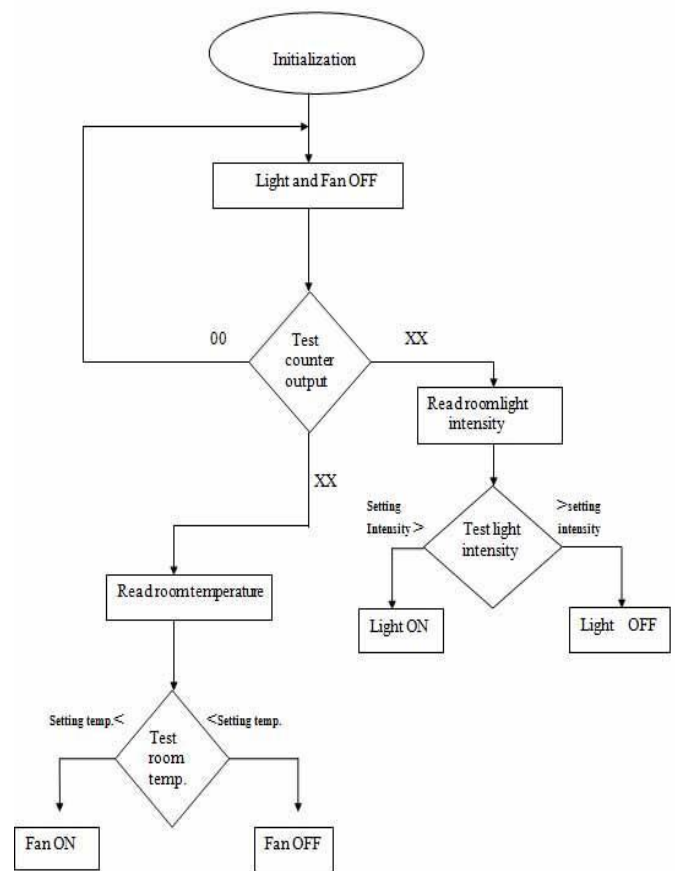

Fig.3.2: The Flow chart of the designed system

PIC16F873 is used as microcontroller for this work which is manufactured by Microchip Technology Inc. The microcontroller is powered with +5V through a battery (for the convenience of the work). For the functioning of the microcontroller a crystal oscillator is used. The microcontroller get input signals from the bidirectional visitor counter, LDR, temperature sensor LM35 and send output signals to the LCD display, light, & fan. Regard as a particular room or office in a building which is connected to our experimental kit. Light for the variation of resistance. When light falls on the narrow piece, the resistance decreases.

In the deficiency of light the resistance can be 10k to 15k. Hence voltage drop across LDR also changes with the intensity of exposing light. The variable voltage of LDR is applied to the input of the MCU (pin 3, RA1), is compared with threshold voltage applied to the MCU (pin 5, RA3). When the voltage is less than the threshold voltage MCU provides 1 (high voltage) to the dimmer1 circuit which switches the light, through the output pin 13 (RC2). Light intensity can be controlled by the variable voltage drops of LDR. Here we make use of LM35 temperature sensor whose output voltage is linearly proportional to the Celsius (Centigrade) temperature. The LM35 is rated to operate over a -55° to +150°C temperature range. It varies 10mv of the output voltage of LM35 for the change of per degree centigrade temperature. The variable voltage of LM35 is

applied to the input of the MCU (pin 2, RA0), is compared with threshold voltage applied to the MCU (pin 4, RA2).

When the voltage is greater than the threshold voltage, MCU provides 1 (high voltage) to the dimmer2 circuit which switches the fan, through the output pin 12 (RC1). The speed of the fan can be controlled by the variable voltage drops of LM35. With the increase of output voltage of LM35, the speed of the fan is also increased. We bring into play an LCD display which has 14 pins, where pin 4 is connected to output pin 25 (RB4) of MCU, pin 6 to output pin 26 (RB5) of MCU, pin 11 to output pin 21 (RB0) of MCU, pin 12 to output pin 22 (RB1) of MCU, pin 13 to output pin 23 (RB2) of MCU and pin 14 of the LCD display is connected to output pin 24 (RB3) of MCU. The room temperature and the threshold temperature are shown (1, 3) and (1, 9) lines of LCD respectively. The liquid crystals can be controlled through an applied electric voltage so that light is allowed to pass or is blocked. By carefully controlling where and what wavelength (color) of light is acceptable to pass, a backlight provides LCD monitor's brightness.

3.3: Smoke sensor unit

Smoke sensor module is used for detecting smoke within the room. When smoke sensor senses smoke, that is, when the sensor's smoke sensing branch voltage exceeds the reference level called threshold level the output of the sensor is activated and the microcontroller receives the sensor output and the microcontroller send an output signal to act an alarming system. This system also contains 5w (4 ohm speaker) alarm. After sensing the smoke the sensor is kept inactive for 5 minutes. By using the following flow chart we can write the source code for the security control unit.

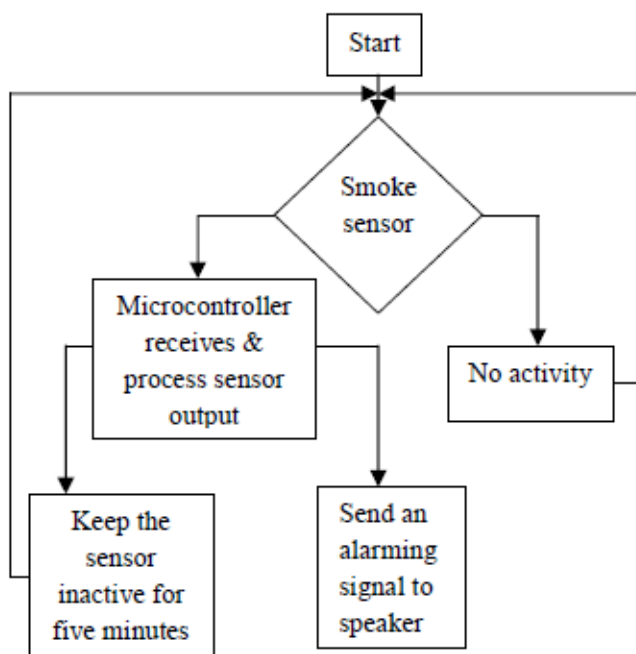

Fig.3.3: Flow Chart of the Smoke Sensor

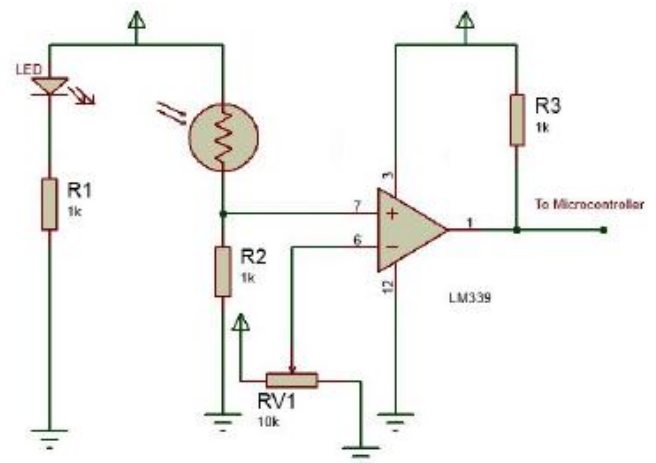

Fig.3.4: Smoke Sensing Circuit

3.4: PIR Sensors

PIR sensors are passive electronic devices. Once the motion is detected by sensing infrared fluctuations, a high is sent to the signal pin. These sensors work well in detecting human motion. PIR sensors are composed of a solid state pyro electric chip. When exposed to infrared radiation, the chip generates an electric charge and this charge is amplified by an amplifier and thus the output voltage can be interfaced with other devices. The PIR Sensor has a range of approximately 5 meters and it can sense object up to 120° within a meter range. The sensitivity is enhanced by a translucent Fresnel Lens which covers the chip and it varies with environmental conditions. The sensor adjusts to slowly changing conditions but whenever there is a sudden change it responds by making its output high.

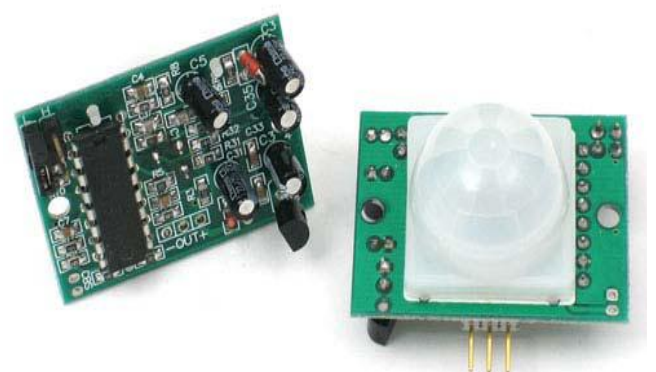

Fig.3.5: Basic PIR Sensor

4. CONCLUSION

Home automation with considering Energy Saving System is not limited for any particular purpose, it can be used anywhere in a developing industry with little modifications in software coding according to the necessities. This concept can be used in many developing countries in order to save their limited power. It ensures that

our work will not only be usable in the future but also provides the flexibility to adapt and extend, as needs change. In my seminar I associated all the sensors to micro controller with the wires. This can be originated with wireless such that we can put different sensors in different places. This sensor will turn on the micro controller with the signals instead of using wires. We can send this data to a distant location using mobile or internet. Voice alarm system can be included to indicate that the room is full & persons can't enter inside. This system can also be applied to various loads like pressure, force and etc. by increasing the number of ports of the micro controller.

REFERENCES

1. A. Mathur, K. S. Nagla, "Microcontroller-based Bidirectional Visitor Counter" *Electronics for You*, pp.78-81, January 2007. [Online] Available: <http://www.scribd.com/doc/49533576/Bidirectional-Visitor-Counter>, accessed in December 2012
2. B. Collis, "An Introduction to Microcontrollers and Software Design," MRGS Technology Electronics, 2003, pp. 40-44.
3. Dean, K.J. "Design of bidirectional coherent counters," *Proceedings of the Institution of Electrical Engineers*, Vol.113, Issue. 11, pp.1751-1754, January 2010.
4. *Electronics* (August 27, 1998) ISBN-13: 978-0079137166, Electus Distribution Reference Data Sheet: OPTOCOUP.PDF, 2001.
5. G. K. Dey, R. Hossen, M.S. Noor and K.T. Ahmmed, "Distance Controlled Rescue and Security Mobile Robot," *International Conference on Informatics, Electronics & Vision (ICIEV)*, pp: 1-6, May 2013.
6. Golay and Marcel J.E., "The Logic of Bidirectional Binary Counters," *IRE Transactions on Electronic Computers*, vol.EC-6, pp.1-4, August 2009
7. Interface LM35 with Atmega16, AVR microcontroller projects [Online]. Available: <http://avrprojects.info> Binu, "Zero Crossing Detector for Microcontrollers," [Online]. Available: <http://www.8051projects.info/blogs.asp?view=plink&id=198>.
8. Lipu, M.S.H., Karim, T.F., Rahman, M.L. and Sultana, F., "Wireless security control system & sensor network for smoke & fire detection," *IEEE International Conference on Advanced Management Science (ICAMS)*, vol.3, pp.153-157, 2010.
9. MOC3020 Thru MOC3023 Optocouplers/Optoisolators datasheet, Texas Instruments Incorporated, 1998.
10. MykePredko: "Handbook of Microcontrollers", McGraw-Hill/Tab
11. PIR Sensor (#555-28027) datasheet, Version 1.2, Parallax Inc., Feb. 2007 [Online]. Available <http://www.parallax.com/dl/docs/prod/audiovis/pirsensor-vl.2.pdf>.
12. Wei Yan and S.Y.R. Hui, "Dimming Characteristics of Large-scale High-Intensity-Discharge (HID) Lamp Lighting Networks using a Central Energy-Saving System," *Industry Applications Conference, 2006*, vol.3, pp.1090-1098,2006.