

Smart and Energy Saving System for Auditorium using PLC Automation

Ankita Yadav¹, Komal Bandle², Manasi Bajare³, Prof. S. A. Patil⁴

¹⁻⁴ Electronics and Telecommunication Dept., At Pimpri Chinchwad College of Engineering Pune.

Abstract - In this modern and advancing world with young generation who is growing and getting smart, the campus premises should be smart too. So here is one of the solution of auditorium automation where there's no need to operate any appliance through switches. The fans will work automatically according to the temperature and presence of people in the room. Lamps or tubes will get turned ON according to the luminous intensity and this occurs only when person is present in hall. There will also be automatic door control system, which will open automatically during entrance and exit of people. The paper also focus on counting the number of people that enters or leaves auditorium or conference hall and the total count will be displayed on the screen present outside. Door control system can provide two benefits: it can ensure high security as well as help disable persons. The system also consists of an app which will store all the necessary information about all the auditorium halls in the building along with which meeting is being conducted in any hall. This meeting information will be displayed on the screen present outside auditorium hall. The Entire system is controlled using PLC and focuses on energy saving.

Key Words: Automation, PLC, Application, Various Sensors, Secure System, Contactless system

1. INTRODUCTION

Our project is an example of industrial automation. Most of the times, due to human laziness, a lot of issues occur. People often seem to forget to switch off lights & fan, so a lot of wastage of power takes place in malls, auditorium, museum etc. The authorities of these buildings have the responsibility to off all loads which can be sometimes unreliable. There is also a need to guide and inform people about the meetings conducted in each auditorium hall. To ensure safety of all the people the system needs to be as contactless as possible. So there should be provision for opening and closing auditorium doors without touching.

Security is requirement of throughout the world and lack of security can lead to unpredictable damage. So, using PLC automated doors do not just improve the appeal and standard of any office but also make automatic entry for incoming and outgoing people. Due to lockdown, such huge places and premises that attract crowd are closed down to stop the spread of COVID 19 virus. But if we increase security and make the whole system contactless, people can carry on their meetings without much worry. All the electronic devices in the auditorium doesn't need to be operated via switch. They will depend on the number of people present in the

auditorium. The doors will open and close for the people eliminating the need to touch the doors. The status of each auditorium hall will be stored in the app which will help the organizing team keep track of the activities in the auditorium. The system will also display the number of people present and which meeting or event is going on in the hall to avoid unnecessary disturbance.

All the operations are controlled via PLC. As PLC has evolved as a main controller in industries nowadays. This is because of the simplicity and robustness of the PLC.

2. Proposed System

After doing lot of research and study some papers found out to be valuable resources for development of the project. All contains different methodologies and techniques which are used to achieve automatic energy efficient and user friendly Auditorium/meeting halls.

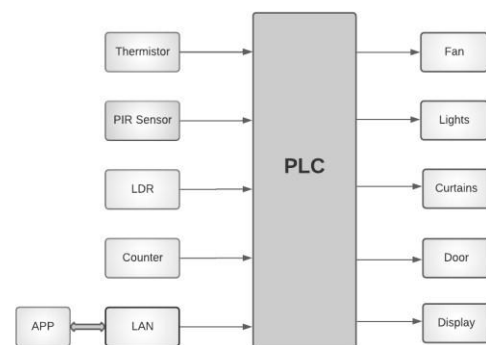

Fig - 2.1 : Block Diagram

In our project we used various sensors. We proposed the system of automatic door which opens and closes the door automatically. It also contains counter to maintain record of people present in auditorium/halls/room. As soon as room reaches its maximum limit the door gets automatically closed [5]. All the room appliances are controlled automatically as well as manually s[1][2][4]. As soon as person enters into the room its presence is detected by PIR Sensor. PIR sensor is used along with Thermistor and LDR. So that depending on the presence of person in particular region and also LDR the lights of that part of room gets turns on/off. Similarly based on temperature and human presence respective fans will turn on/off. These is used to save electricity and to avoid manual labour work [1][2][4]. Also based on the projector status the blinds and lights of the rooms controls which avoids manual human operations. An App is also design to schedule meetings or events in room and also keep record and control remote operations of

appliances [3][1]. The details of meeting get displayed on the Display placed outside the Hall so as to avoid confusion and make ease of scheduling the meetings/events in large offices/colleges. These makes use of Ethernet port which is available on PLC and also using LAN and servers.

3. Methodology

When a person is detected near the door, it automatically opens to let the person in or out without manually opening it and making the whole process contactless.

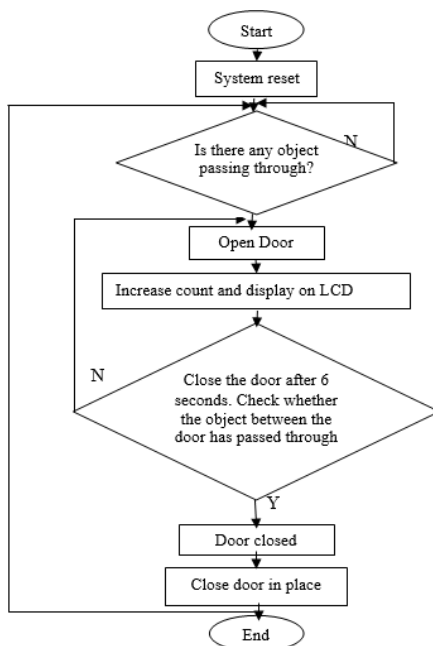

Fig - 3.1: Automatic Door Opening Flow Chart

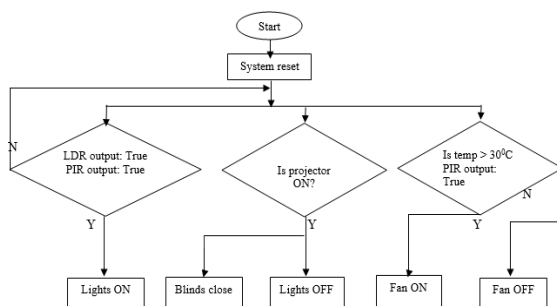

Fig - 3.2 : Auditorium hall automation flow chart

- Depending upon the person passing through entry or exit door, the total count of the people inside the auditorium will be counted continuously and simultaneously displayed on the screen present outside to keep everyone informed.
- The screen will also display which meeting or event is being conducted inside the auditorium hall with the help of app to organize everything efficiently.
- The LDR and PIR sensors present inside the auditorium will continuously detect movement and presence of

people and accordingly turn on the lights in the hall. If no presence is detected the lights would automatically turn off.

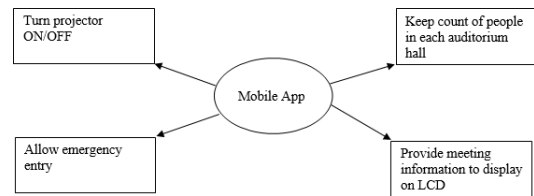

Fig 3.3 : Record maintenance flow chart

- The Temperature sensor will sense the temperature inside the hall and if the temperature is above the threshold value, the fans in the hall will automatically turn on.
- If the projector is rolled down and the presentation is going on, the lights will turn off and the window blinds will close otherwise open.

4. Specifications

4.1 PLC (FX5U Mitsubishi):



Fig 4.1: PLC (FX5U Mitsubishi)

Voltage rating for PLC ranges between 100VAC and 240VAC we decided to use PLC over microcontroller. Also by combining I/O expansion modules we can build complex applications. This PLC can indicate input and output states via LEDs. Also has real time clock integrated. And it can be programmed using GX Works3 software.

4.2 PIR Sensor

In proposed system PIR sensor is used to detect motion in and out of room their by keeping count of the people in room and controlling lights. PIR sensors are small, inexpensive, Low power and easy to use. The PIR sensor has two knobs on the back for adjusting the sensitivity and for charging the pulse time.



Fig 4.2: PIR Sensor

4.3 Display

We are using display in order to show which meeting is going on and further scheduled meeting. And also count of people inside room. We will be using OLED display due to its better contrast, viewing angle and low power consumption Compared to other display types



Fig . 4.3 Display

5. Conclusion

We have carried out the research and study in the area of PLC Automation to find out current challenges and scope of work. After the review, we were found many issues like that Controlling method for new technologies, New trends in PLC Automation, Wireless Data Transmission & Energy Saving should be given proper concern as there is continuous advancement in technology every day. These papers are a comparison result of different security issues & controlling related work that is carried out in the area of integrity. Propose of these models are to reduce the security risks and improve system reliability and make the system automated. The technology and trends are changing every day in the automation field. Nowadays, simulation software has made its own place in this industry. Time is also important. The exhaustive review could finally lead to extract findings in the area of PLC Automation, strengths and weaknesses and scope of work in future.

Implementation of Such System will help us in various aspects. Majorly it will save a lot of energy and its wastage will get reduced drastically. Right from entrance we trying to automate everything in room. Doors will open automatically when the presence of concerned person detected. This will mainly help disabled individual and also helps in maintaining security. The whole process in the auditorium will be automated to make the operations and meetings happening inside will be hassle free.

The review of all the papers suggest, to carry out automation at such a high level PLC is the best choice.

6. References

- [1] Vibhuti and Shimi S.L. ,“Implementation of Smart Class Room Using WAGO PLC”, 2018 Second International Conference on Inventive Systems and Control, IEEE Xplore Compliant- Part Number:CFP18J06-ART, ISBN:978-1- 5386-0807-4; DVD Part Number:CFP18J06DVD, ISBN:978-1-5386-0806-7
- [2] Jankar Pranjal Bapu, Rutuja Devendra Kenjale, Attar Karishma Shabbir and Prof. Shrikant Mangate, “Power saving in auditorium by automation with power quality analysis.”

2017 IJRTI | Volume 2, Issue 4 | ISSN: 2456-3315

[3] Linh Duc Tran, Alex Stojcevski, Thanh Chi Pham, Tony de Souza-Daw, Nhan Trong Nguyen, Vinh Quang Nguyen and Chau Minh Nguyen ,“ A Smart Meeting Room Scheduling and Management System with Utilization Control and Ad-hoc Support Based on Real-Time Occupancy Detection” 2017 Centre of Technology, RMIT University Vietnam, Ho Chi Minh City, Vietnam

[4] Md. Kamrul Hassan Majumdar, Himel Biswas, Md. Haider Ali Shaim, Kazi Tanvir Ahmmed ,“ Automated Energy Saving and Safety System ”, International Conference on Electrical Engineering and Information & Communication Technology (ICEEICT) 2014, 978-1-4799-4819-2/14

[5] Ritu Phogat and Lokeshwar,“ Implementation of Door Control System Using Ladder Language”, 2014 International Journal of Science and Research (IJSR) p.i 0201517 doi – 7/7/201 The review of all the papers suggest, to carry out automation at such a high level PLC is the best choice.