

Automatic Car Door Handle Sanitizing System

Abhishek More¹, Esha Ubale²

Abstract - Automatic door sanitizer. It is specially designed for people who have to travel by a cab or a car during COVID 19 pandemic.

It is for the safety of people and to reduce the spread of coronavirus. All equipment and chemicals used are researched and designed by us keeping in mind the safety of the car and the driver. This idea aroused when the entire country was getting ready for Unlock -1. Where the safety of people was at the highest priority. We are planning to implement our products on door handles on cars of our health line workers and police who were busy working even during pandemic keeping our country safe without thinking about their own life. This will benefit people to sanitize their hands without touching their bag or pocket to remove sanitizer bottle.

Key Words: Quaternary Ammonium compounds, Door Handle, Sanitization, Electronics, FEA

1. INTRODUCTION

It is used to dispense any sanitizing fluid. It is a touch less operation which makes people fearless while travelling in a cab during this pandemic.

As per the set timer, it allows 20.8mL fluid at one instant of time. It is a fully leak proof heavy duty product which has a robust construction and an easy to install design. The installation is effortless as every component can be easily mounted on the mounting plate and it can be easily placed on the inside wheel well on the damper mounting point.

A separate power cable is provided which is of 12V so that other electronic components are not overloaded. It is designed as per the standard power input of 12V.

1.1 Quaternary Ammonium Compounds

Quaternary Ammonium Compounds are one of the most extensively used active agents in disinfectant products because of certain advantages of Quaternary Ammonium Compounds which include, good stability and toxicology, surface activity and compatibility with cleaner formulation ingredients, and lack of odor. These properties make it well suited for consumer products that combine cleaning with disinfection. Quaternary Ammonium Compounds are non flammable so they are the ideal disinfecting or sanitizing solution to be used and stored in an Automobile.

2. COMPONENTS

2.1 Sanitizing fluid reservoir tank

Sanitizing fluid reservoir tank for is externally formed with a side stepping surface, and is internally defined with a space for storing sanitizing fluid replenished through a feeding pipe having a cap, and for allowing sanitizing fluid stored therein to be pumped to spray nozzles on the door handles of the vehicle through supply hoses under the operation of a supply motor pumps.



Fig -1: Sanitizing fluid reservoir tank Tank

2.2 Pump

Pump forces the sanitizing fluid from the reservoir tank to the spray nozzles through the fluid hoses. The selected pump is a short tubular 12V pump which can deliver upto 250ml per minute of flow rate at pressure of 38psi. There are four pumps (separate pumps for each door).



Fig -2: Pump

2.3 Spray Nozzles

Spray nozzles are used to spray a fine mist of the sanitizing fluid on the door handle and grab the area of the door handle whenever the door is opened.



Fig -3: Spray Nozzle

2.4 Controller

The controller is responsible for switching on the correct motor driver so that fluid is sprayed to the door which is opened, for this input signal is taken from the door light switch and the respective motor driver is switched on. The controller selected is Raspberry pie 4 as it gives fast response hence the time required for the entire cycle is reduced and fluid is sprayed exactly on time.



Fig -4: Controller

2.5 Motor Driver

The Motor Driver will receive an on or off signal from the controller and according to that signal it will switch on or switch off the 12V pump to regulate the flow of sanitizing fluid.

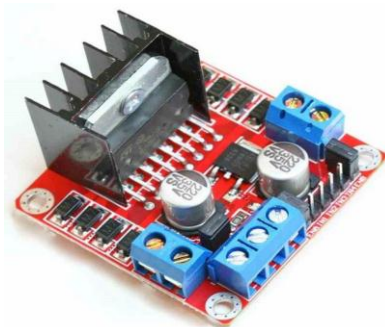

Fig -5: Motor Driver

2.5 Mounting Plate

The mounting plate is designed in such a way that all the components (reservoir tank, pumps, controller, and power cables) can be mounted on it and the plate can be bolted with the rear suspension damper mounting.

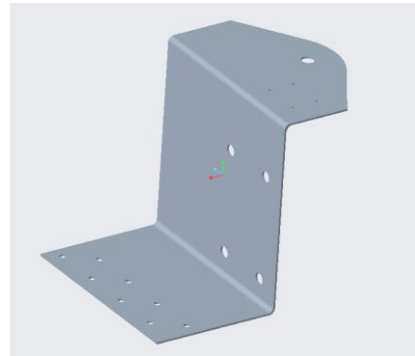

Fig -6: Mounting Plate

2.5 Extended Switch coupler

The extended switch coupler is designed as an extension between the OEM Coupler and the Door light switch so that we can take input signals from the door light switch without cutting or tapping the OEM circuit. This extended coupler is designed in such a way that it can be connected directly in between with the Door light switch and OEM coupler so warranty of the car is not hampered.



Fig -7: Door Light Switch

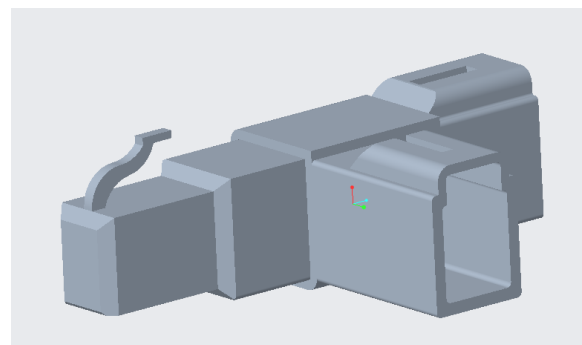

Fig -8: Extended Switch coupler

3. FEA analysis of mounting plate

For Analysis of Mounting plate Ansys R3 was used. The final results were obtained by analyzing the mounting plate.

The forces considered include the weight of all the components of the system, weight of the sanitizing liquid when the tank is full and the forces acting on the plate due to motion of the vehicle. And the design was safe according to results.

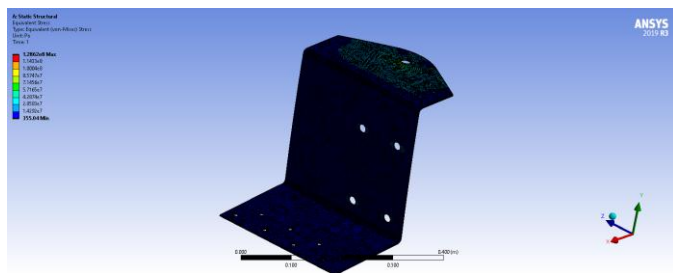

Fig -9: Stress in Mounting Plate

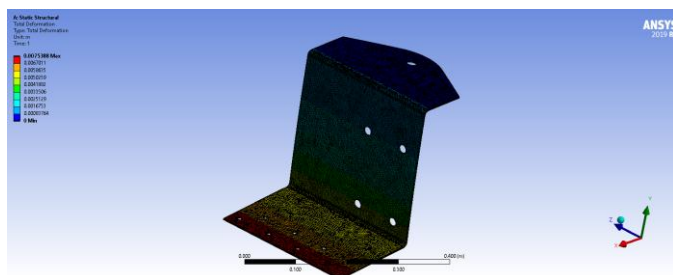

Fig -10: Highest deformation in Mounting Plate

4. Working

In compliance with the circuit design, when the door is opened the respective door light switch gets connected with the body of the car (body of the car is always grounded with the negative terminal of the battery) and sends a signal to the controller

Due to which the controller turns the respective motor driver on which is responsible for operation of the pump, pump will be activated for 5 secs and sanitizing fluid will be sprayed onto the door handle and handle grab area, after 5 secs motor driver is turned off due to which spray of sanitizing fluid also stops. This cycle repeats after the door is closed and opened again.

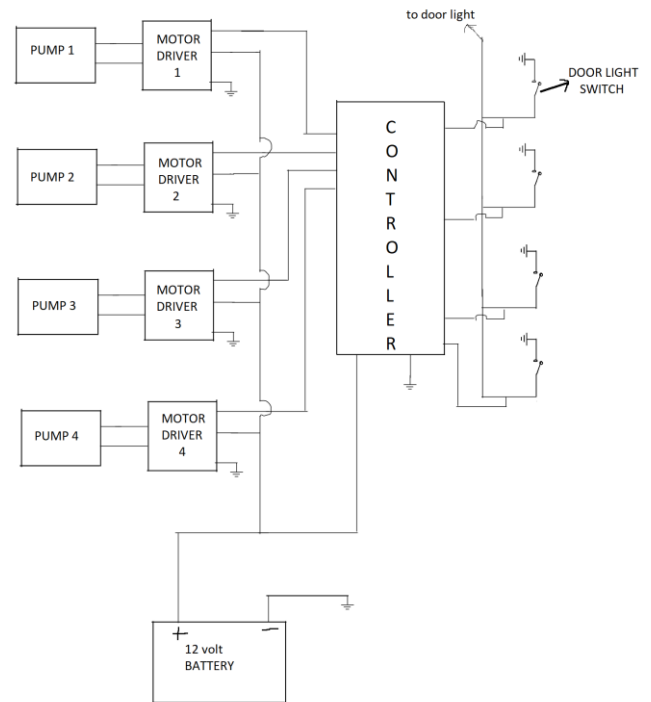
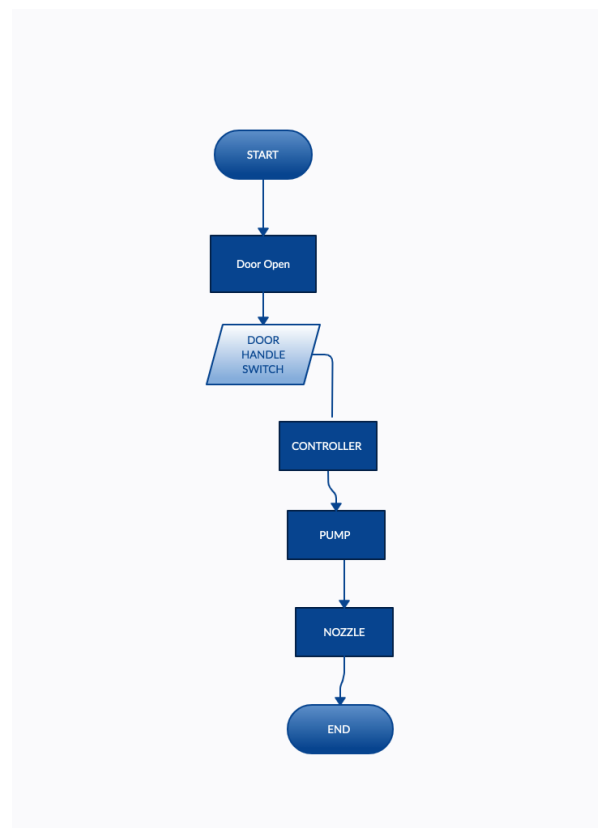

Fig -11: Circuit Diagram

4.1 WORKING FLOW CHART



5. Conclusions

It is a successful operation, tried and analyzed.

On the basis of finite element analysis, we have made our own mounting plate. This plate is strong enough to manage all the components i.e. weight of the fluid, weight of the tank etc.

The whole operation completes in very less time. As soon as the door opens the signals are sent and the operation completes with the sanitizing fluid being pumped out. This process takes place in a matter of a few minutes.

Another profit is that the manufacturing cost is extremely low.

REFERENCES

- [1] Kampf, G.; Kramer, A. Epidemiologic background of hand hygiene and evaluation of the most important agents for scrubs and rubs. *Clin. Microbiol. Rev.* 2004, 17, 863–893
- [2] Edward Fu, Diane Boesenberg, *Handbook for Cleaning/Decontamination of Surfaces*, 2007
- [3] Ansari, S.A.; Springthorpe, V.S.; Sattar, S.A.; Rivard, S.; Rahman, M. "Potential role of hands in the spread of respiratory viral infections: Studies with human parainfluenza virus 3 and rhinovirus 14". *J. Clin. Microbiol.* 1991, 29, 2115–2119
- [4] Gerberding, J.L.; Fleming, M.W.; Snider, D.E., Jr.; Thacker, S.B.; Ward, J.W.; Hewitt, S.M.; Wilson, R.J.; Heilman, M.A.; Doan, Q.M. "Morbidity and Mortality Weekly Report Guideline for Hand Hygiene in Health-Care Settings; Recommendations of the Healthcare Infection Control Practices" Advisory Committee and the HICPAC/SHEA/APIC/IDSA Hand Hygiene Task Force; Centers for Disease Control: Atlanta, GA, USA, 2002; Volume 51
- [5] Andrew J. McBain, Ruth G. Ledder, Louise E. Moore, Carl E. Catrenich, Peter Gilbert, "Effects of Quaternary-Ammonium-Based Formulations on Bacterial Community Dynamics and Antimicrobial Susceptibility", *Applied and Environmental Microbiology* Jun 2004, 70 (6) 3449-3456; **DOI:** 10.1128/AEM.70.6.3449-3456.2004
- [6] SYSTEM WIRING DIAGRAMS Article Text (p. 14) For 1996 Suzuki Esteem
- [7] PRASAD D. KULKARNI, Text book of Automotive Electrical and Electronics systems.