

WOMEN SECURITY SYSTEM

Rohini Chavan¹, Snehal Shinde², Trishala Shendage³, Mr. P.G.Kamble⁴

^{1,2,3}Electronics & Telecommunication Engg., Sanjay Ghodawat Institutes, Kolhapur-416118, Maharashtra, India.

⁴Professor, Electronics & Telecommunication Engg., Sanjay Ghodawat Institutes, Kolhapur-416118, Maharashtra, India.

Abstract: Women security system device is more like a safety device in case of crisis. Now a days, women feel insecure in the entire globe in all aspects. Hence a new system is built using ATmega16A controller, GSM & GPS system. This device provides quick response to those who are under threat. In order to overcome various crimes against women this system provides slight contribution. The device can be inserted or fitted in the jacket/blazer of women. During emergency in harassment, she can press the button in which the current location of the victim will be sent to the numbers that are already located in the system. This Location will be in terms of latitude & longitude. This new system is interfaced with push button, GPS module, GSM module. The system capability provides real time response, such that women can feel secure and can be protected.

Key Words: ATmega16A controller, GSM, GPS, Switch, Latitude, Longitude, Safety.

1. INTRODUCTION

The women security system in emergency and crisis is used to intimate the parents as well as police about the current location of the women who is under threat. This device is useful for the security purpose in order to meet the above requirements. Hence we have designed a system that will suffice the problems like harassment, abuse, violence etc. It is very easy to carry with more features and functions. This system is very helpful and important in India and across the globe as crimes are increasing day by day. We kept the main device separate from emergency switch button. The main device and switch has wireless connection. The emergency switch button is held to one of the buttons of jacket. The main device includes GPS & GSM module. The GPS system will trace the current location, while GSM system will send the message to the numbers saved in the system. The idea to develop this model for women is that it's safe and user friendly. A recent literature review [1] presents a fast responding method that helps women at the time of trouble. The world is now becoming risky for women in all directions. Now a day's she is not safe because of increasing crimes against her at higher rate. The educated women feel unsafe because of increasing crimes. Whenever anybody tries to indulge or harass her, she can press the button that is attached to device and the

location will be sent to numbers that already saved in system. Location is in terms of latitude and longitude. The microcontroller used is PIC16877A. It is connected with push button, a GPS module, a GSM module and speech circuit. If switch is pressed speech circuit activates and it capture attention of nearby people for help. In this system program is developed in embedded language. This system gives slight contribution to protect girls from crimes.

The second paper [2] deals about an intelligent security system for women. Now a days, young girl and women suffer and fear from various types of harassment to sexual incidents like rape and femicide. It is observed on streets, public transport, parks, around schools and workplaces. A new report from WHO tells 35% of women in worldwide have experienced violence. It includes a monitoring device, the output of which is processed to determine insecure environments. The microcontroller PIC16877A is used. This system can placed in public places, bus stands, foot paths and shopping malls where women are experiencing attacks.

This paper [3] narrates about an one touch alarm system for women's safety using GSM. This device provides protection to women. This helps to protect and call on resources that help to come out of dangerous situation. The system includes PIC microcontroller, GPS modules, GSM modules. The main advantage of this system is that, it is not necessary to carry smart phone by user.

Now a days, women & children safety is major thing of our society. The number of victims increasing day by day. Many miserable things have been taking place. This paper [4] talks about design of embedded device. This device fitted inside shoe & android application is developed for safety of women. This application can be operated by clicking a single button, whenever a women in trouble. This app recognizes current location & message send to predefined numbers.

In the current situation, the first question in each women's mind is about her safety & security. This paper [5] suggests a new perspective to use innovation that save women's life. The wearable system correspond to a simple watch with a button. Women can press button when she feel

uncomfortable and system gets turn on. When system switched on, it tracks location by Global Positioning System (GPS) & send mail to the person who can help her.

India which sees itself as a encouraging super power & economic hub, is still suffering through unexpected incidents like molestation, rape, murder against women. This paper [6] represents about safety device which consists a microcontroller, a heartbeat sensor, a temperature sensor, an emergency switch. To notice emergency situation, this system fetches current location of women & send it to saved number via GSM module. The shock giver circuit is designed to hurt attacking person.

2. BLOCK DIAGRAM

Fig.1 & 2 shows the block diagram of our project. This project work is divided into two parts :

- Transmitter section
- Receiver Section

Transmitter Section

This consists of RF module, Encoder, Electronic Switch and Battery. If electronic switch is pressed, then the data is sent to the encoder. The Encoded information is then sent to the RF module & transmitted through antenna. Battery provides supply to transmitter section.

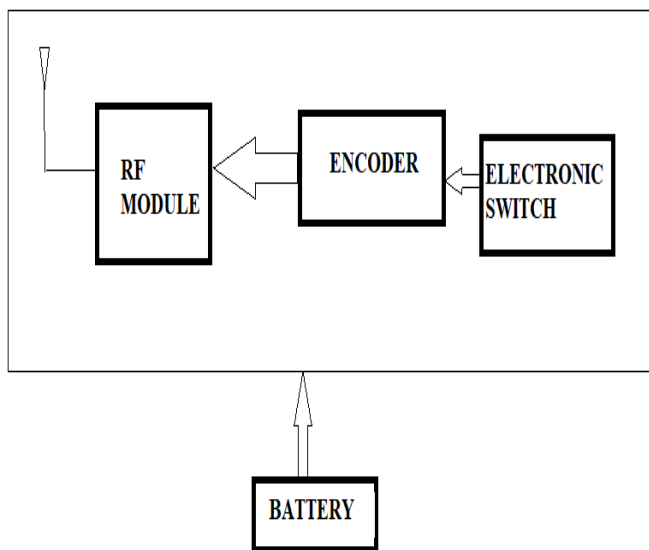

Fig.1

Receiver Section

This consists of RF module, Decoder, Microcontroller, GSM & GPS system, Battery, LCD Display, Buzzer. Transmitted data is received by receiver and is decoded with the help of decoder. Decoded signal is then sent to the microcontroller ATmega16A which activates GSM & GPS system. The Output will display on LCD screen.

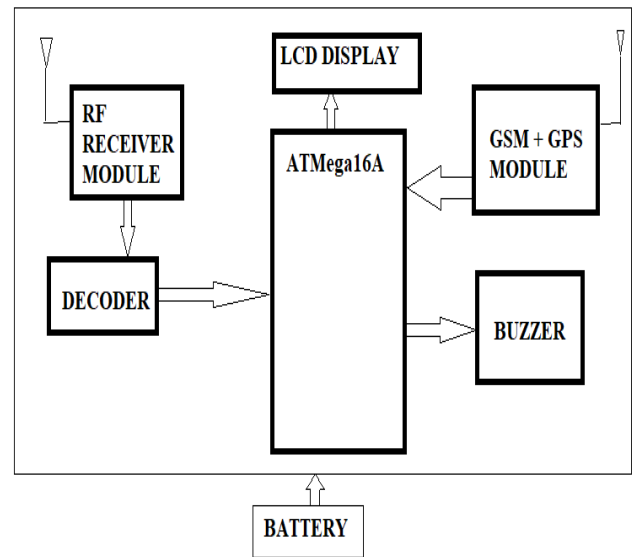

Fig.2

3. WORKING PRINCIPLE

It contains RF module (RF module is nothing but radio frequency module used to transmit & receive radio signals. It is used to communicate wirelessly with another system), Encoder (HT12E encoder) which converts parallel data serially, Electronic switch, Battery, Decoder (HT12D decoder), RF receiver, GSM & GPS module (SIM808 has combined GPS & GSM module), ATmega16A, LCD display. The main heart of this system is the ATmega16A controller. When we press electronic switch, HT12E encoder will provide a signal as ON or OFF. If signal is ON then RF module will transmit a signal to receiver module. 2-12v supply voltage is required to operate this system. Transmitted signal is received by RF receiver module. HT12D decoder is used to decode the data. GPS system will give current location in terms longitude & latitude. Global System Module will send message to contact number saved in that system. Status of GSM & GPS system will be shown by LCD display. The entire system is controlled by ATmega16A (ATmega16A is a High-performance, Low-power Atmel Advance Virtual Risk 8-bit Microcontroller. It has Advanced RISC Architecture).

4. RESULTS

During crisis when the victim presses electronic switch current location is captured by GPS module. This location is in terms of latitude & longitude. These coordinates are sent to predefined number by GSM module. The message like "Emergency at (Latitude, Longitude)" will be displayed as shown below. Thus victim will be protected when message reaches to parents & police station whose numbers are already saved in module.

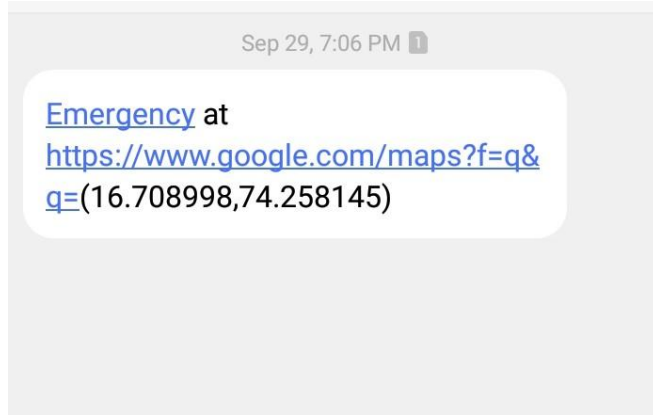

5. FUTURE SCOPE

In future, the system can also be interfaced with the Camera for capturing image and recording live video. We can interface this system using smart phone or mobile. This system can be further connected with vehicles with air bag system. The more effective system can be designed by inserting MOTION DETECTOR Technology.

6. CONCLUSION

Our attempt behind this project is to design and fabricate a device which is so compact in size that provide advantage of personal security system. The emergency response system which is advantageous for women in the case of crime. It is a low cost system which saves data and give quick alert in case of crime against women. This provides

women security who can be safe and secured.

7. REFERENCES

- 1] Sriranjini, "GPS & GSM based Self Defence System for Women safety", Journal of Electrical and Electronics Systems, Volume No.06, pp[03], 2017.
- 2] Remya George And Anjaly Cherian, "An Intelligent security System for Violence against women in public places", International Journal of Engineering & Advanced Technology, Volume No. 03, pp[05], April 2015.
- 3] Premkumar, Ravivarma and Sharmila, "One Touch Alarm System For Women's using GSM", International Journal of Science, Technology and Management, Volume No.01, pp[04], March 2015.
- 4] Pooja Kabsud and Vishnu Suresp, "Innovative Embedded Shoe Design for Women Safety", Volume No.08, International Journal of Engineering Research & Technology, pp[05], February 2019.
- 5] Rajesh Kannan M., Jyothsna K., Aparna T. S., Anjali T., Meera M., Amrutha S.D. "IoT-Based Women Security System", Inventive Communication & Computational Technologies, Volume No.89, 30 January 2020.
- 6] Yatharth Choudhary, Surbhi Upadhyay, Dr. Rita Jain, Abhishek Chakraborty, "WOMEN SAFETY DEVICE (SAFETY USING GPS, GSM, SHOCK, SIREN AND LED)", International Journal Of advance Research In Science & Engineering, Volume No.6, Issue No. 05, May 2017.

BIOGRAPHIES

1. Ms. Rohini B. Chavan.
Degree student at Sanjay Ghodawat Institutes. (E&TC)
2. Ms. Snehal S. Shinde.
Degree student at Sanjay Ghodawat Institutes. (E&TC)
3. Ms. Trishala S. Shendage.
Degree student at Sanjay Ghodawat Institutes. (E&TC)
4. Mr. Prasan .G. Kamble.
ME E&TC. Professor at Sanjay Ghodawat Institutes.