

DESIGN AND DEVELOPMENT OF A CONCEPTUAL ELECTRIC FLYING VEHICLE

Sudhanshu Suhas Rankhambe¹, Aditya Pradhan Magdum², Krupal Vinod Chavan³, Juned Akhtar Akhlaq Ahmad Desai⁴, Rushikesh Shrikrushna Khandkole⁵, Ashish Arunrao Desai⁶

¹⁻⁵Mechanical Engineering student at Sharad Institute of Technology College Of Engineering, Yadrav(Maharashtra)India.

⁶Assistant Professor, ME in CAD/CAM/CAE, Sharad Institute of Technology College of Engineering, Yadrav (Maharashtra) India.

Abstract: In this modern era of technological innovations, the conceptual things that we were dreamt of are coming in real life. Vast research in the field of aviation and robotics has now opened up many doors to the future of flying vehicles. Huge innovations in electrical systems along with advanced programming and technologies like 3D printing have made anything possible. Discovery of more lightweight yet strong materials, powerful yet small-sized motors & batteries, compact electronic systems, reliable balancing systems for aviation, weight reduction design methods, and best manufacturing systems are some of the key points to design a perfect flying vehicle prototype concept. We represented this design concept at SMART INDIA HACKATHON 2020 organized by the central government of India & MHRD and we got the first prize of amount Rs.1 Lakh. The motive of this project is to design an ultra-compact flying vehicle by using all the modern technologies, 3-D modeling software, analysis techniques, all the necessary parameters, calculations, simulation, animation, 3-D printable body along with the best safety features which would make the dream come true of mankind of personalized aviation. The CAD model assembly of our concept is designed and analyzed by various loading conditions for human safety. The obtained results are under the factor of safety. This literature research is just a little contribution to mankind to fulfill the dream of personalized aviation.

Key Words: Flying vehicle, CAD, 3D printing, simulation, personalized aviation.

1. INTRODUCTION:

The present aeronautic trade centers around two essential territories: transportation and the military. The transportation area centers around planning bigger, more proficient, and more solid airplane. The military spotlights on planning more viable, manoeuvre, and lethal weapons [1]. Also, the military has to use most of its air-crafts in rescue missions and operations because, every country faces natural disasters like earthquakes, floods, tsunamis, major snowfalls, etc. Along with these, soldier rescue missions, building collapse rescues, terrorists attack, and many more scenarios happen where soldiers perform rescue operations. The main problem is, the military cannot fly helicopters in

critical areas during the rescue operations. Because, helicopters are bulky, heavy and need much space to operate. Hence a lot of soldiers have lost their lives during these operations. A small, personalized flying vehicle can overcome all these problems. It can reach at any point during critical times and rescue operations. It does not need much fuel, it is not so bulky and can easily reach to such areas and can land easily without any helipad or runway. Also, such a vehicle does not produce much noise, hence it helps to monitor and secure the nation's borders.

There is likewise a private division in the airplane business. Smaller single-motor planes, new helicopters, and other exceptional flying gadgets the entire fall into this classification [1]. Past the private area, there are moreover a few business applications that could profit extraordinarily from the hover-bike-type flying vehicle [2]. A hover-bike type flying vehicle is a mix of a bike and a helicopter. It would seem that straight-forward bicycles. This ducted-fan type bicycle is reliable to work and can be applied to different purposes since it needn't bother with a runaway and is able of floating from any landscape. It is ready to take off and land vertically; hence, the military has appeared to proceed with enthusiasm for ducted-fan vehicles [2][3]. It is aerodynamically proficient because the lift produced by the duct system can make a better thrust force that is higher than the other VTOL vehicles, which have no ducting and in this manner no hover-flight mode [4]. The model we designed is well tested by simulation software and by industry professionals and the Autodesk (India) expertise.

2. LITERATURE REVIEW :

Naware, A., et.all(2018) Concluded that when the hover-bike is compared to a helicopter, the Hover bicycle is less expensive, tougher, and simpler to utilize – and speaks to a different approach to fly. In addition to that, at the point when we supplant the motor with electric engines and batteries, there is a commitment towards the contamination control and additionally, the development of Hover-Bike is likewise basic. At the point when we utilize the electric engine and batteries just inconvenience is the underlying expense of the Hover-Bike is high.

Ninad R. Patil et.al(2017) Explained that the presumed that the original hover-bike utilizes the IC motor as a power source however they were proposing electric energy as a power source. So there was a commitment to contamination control. The main impediment will be its high introductory expense.

Prakash M.et.al(2017) In this research paper the study of solar-powered hoverboard for future transportation has been done. In today's era, the main source of transportation is fissile fuels but it harms the environment. So the main objective of this paper is to develop the solar-powered hoverboard for transportation. In this, the solar cell directly transfers the electric power which is stored in the battery. The microcontroller is used to control the moment of the hoverboard by Bluetooth. Also, the voice command android app is used.

Amit Singh Dhakad.et.al(2014) The research paper contain information about the concept of a flying vehicle. By using our motor vehicle and wings we can lift and the push propeller is used to produce the thrust. By using this concept at a low-cost machine one can fly. This concept gives the personal air bike with multi utilization of flying.

Aditya M. Intwala et.al(2015) Concluded the chassis design and its analysis of vertical take-off and landing vehicles. There is a step by step design procedure of chassis. That is the first 2D modeling then 3D modeling and lastly analysis of the model. For analysis, there is a study of different forces acting on the model. An analysis is carried out on ANSYS software there is a 5% error in all models between calculated and simulated values.

Swaraj D. Lewis et.al(2016) Developed a hoverbike prototype which is one-third in the scale of the actual hoverbike. Made various frame designs to develop the entire prototype. There is a gyroscope system for the automatic balance of the bike. Calculated thrust load to lift the bike in the air. This lightweight prototype can fly in a range of 800 m and is controlled by a remote. This hoverbike has a payload capacity of 0.3 kg and it is very useful in transportation.

3. OBJECTIVES :

1. To reduce traffic problems, to upgrade the military by providing such modern technologies.
2. To design a non-polluting & fully-electric vehicle.
3. To reach critical areas where ambulances, helicopters cannot reach and provide help.
4. For military missions like rescue operations, to supply weapons, border monitoring, and food transport purposes.
5. To provide medical help in disastrous situations.
6. To make the vehicle easy to ride and to handle.
7. To provide all the safety factors into the vehicle so that drivers would be safe in any kind of vehicle accident.

4. METHODOLOGY:

Inspiration is really important before designing a unique and entirely new concept. We took inspiration from the Dolphin and designed the final model. We made 2 variants of our vehicle; 1.With roof. 2. Without a roof (shown in fig.5&8). The design process has gone through various rough sketches and designing the model on software. Here are the previous designs we made,



Fig.1: First design consideration

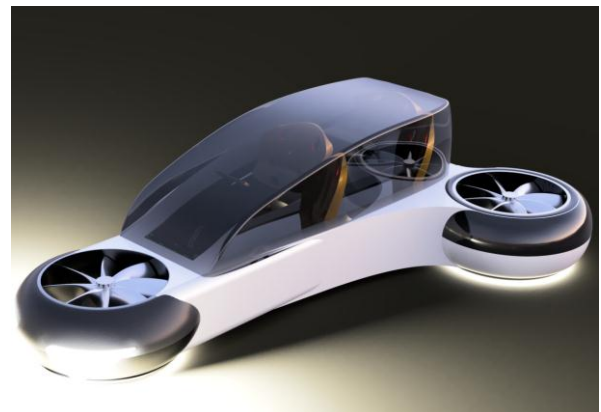

Fig.2: Second design consideration



Fig.3: Third design consideration

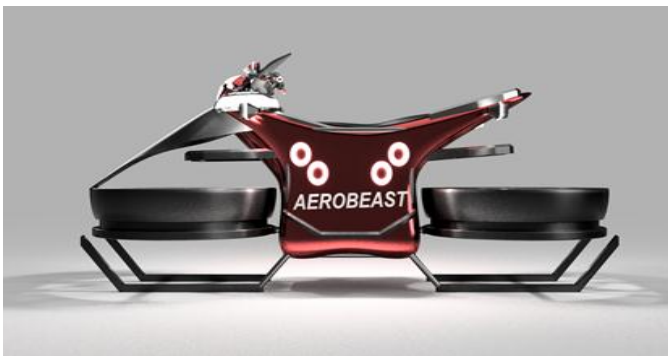

Fig.4: Fourth design consideration

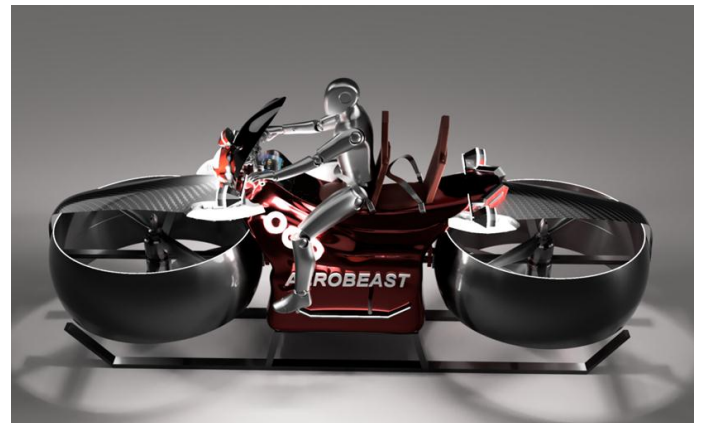

Fig.5: CAD model of the proposed concept of the vehicle. (First variant Without Roof)

The main objective of the design was to make it ultra-compact. Also, the vehicle should be capable of reaching in critical areas and provide help. Hence by considering all these factors we finalized the shape and dimensions of the concept. The next target is to design all the necessary calculatory data, select proper motors, number of motors, and obtain generating thrust. Once finalizing the thrust and motor specifications, the next target is to find out a perfect battery and the overall flight time. The number of propellers and their size is a major point as well. A ducted system for propellers always helps and increases the generating thrust. So we implanted the same. Then the next target is to design the Yaw/turning mechanism. Our concept has a co-axial propeller system hence by using the basic principle of Torque, we designed the turning mechanism. We used generative design, carbon fiber, and Aluminium AISi 10 mg to reduce the weight of the vehicle. We analyzed the chassis on Fusion 360 software. After designing the final model we did airflow simulation to ensure the air flow. The final stage is to provide excellent safety features and emergency systems. It is really important to have good safety features and emergency systems to save the driver from any kind of accident. Hence we designed the best safety features and their respective positions in the vehicle with the help of industry professionals.

5. CONSTRUCTIONAL DETAILS OF THE CONCEPT :

The concept is a compact aerial vehicle with ducted propellers which can increase the thrust compared to a non-ducted propeller system. The concept is electrically powered. Electric motors don't make much noise; they are more efficient than IC engines and are very light in weight. The frame is of Aluminium AISi 10 mg which is fully 3D printable and the rest of the body is made of carbon fiber.



Fig.6: The rendered image of the CAD model.

It consists of a total of 4 electric motors in which two motors along with their propellers are connected at the front end in the vertically opposite direction. And similarly, the same fittings are done at the rear end. It comprises of a coaxial kind of propellers mounted on fast brushless electric motors and controlled by battery-powered Li-Po cells. There are a total of 6 battery units.



Fig.7: A driver is shown onto the vehicle for a better idea.

This vehicle is planned with a ducted fan with the goal that the slip of air is less. Henceforth its streamlined productivity is high. Additionally, it can ready to take off and land

vertically from any landscape. Safety features and all the emergency systems have been designed and showed into the CAD model. The following rendered image is of the second variant that is, the variant with the roof. When the driver goes above 50 feet, he needs more safety. And also the wind speed is higher at those heights. Hence we designed this roof-variant as well.



Fig.8: CAD model of the proposed concept of the vehicle
(Second variant With Roof)



Fig.9: The rendered image of the second variant.

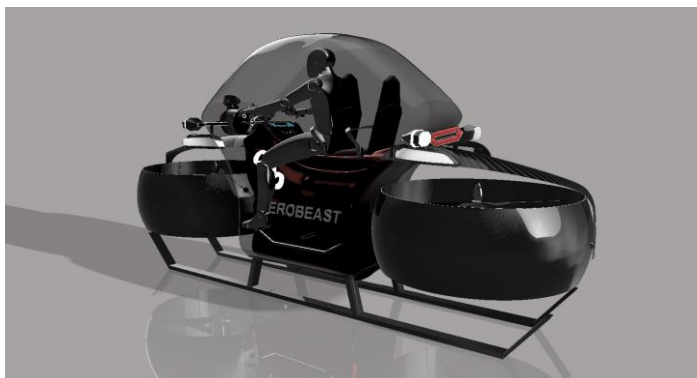

Fig.10: Rear view of the model.

The main components of our concept model are-

1. Frame
2. Propellers
3. Electric motors
4. Batteries
5. Emergency systems
6. PDB & ESC
7. Safety features

5.1. FRAME :

The main goal of the practical design is to develop a lightweight frame, mount batteries, motor with propellers on it and achieve lift. We used FUSION 360 and SOLIDWORKS software for designing and analysis of frame.

- Important factors to be considered for frame: -

 1. The shape of the body should be aerodynamic to decrease the drag offered by air. By considering these points the chassis should be made.
 2. It should cover less floor area.
 3. The material should be light-weighted, low cost, and easy to shape like Carbon Fiber, Aluminum, and polystyrene.
 4. The location of the weights relative to the center of gravity is very important for balancing.

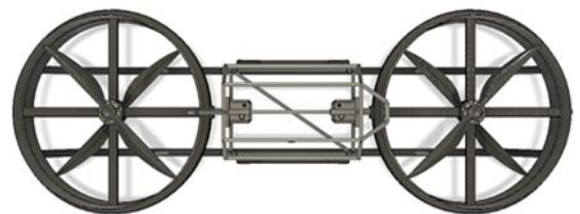

Fig.11: Frame & motor assembly (Top View)



Fig.12: Frame & motor assembly (isometric View)

5.2. PROPELLERS :

Propellers play a very important role to generate the required thrust. These are attached to the motors. To lift the bike in the air it converts rotary motion into linear thrust by creating a pressure difference between two surfaces. Ducted propellers are very efficient; it creates more thrust than any other types, also it provides security to the driver. We are

using the propeller which is capable to lift 102 kg thrust and we are using 4 such propellers which can generate a total thrust of 408 kg. And in this concept we are using ducted mechanism hence the thrust get increased about 62 Kg. Hence the total thrust we are getting is 470 Kg. The 62-inch diameter propeller having 2 blades can fulfill all requirements of thrust and also necessary rpm. Reasons for selection-

1. These propellers provide high thrust.
2. As the material used is carbon fiber so it not only provides greater strength but also light in weight.
3. As there are only 2 blades are used per motor it makes it more efficient.

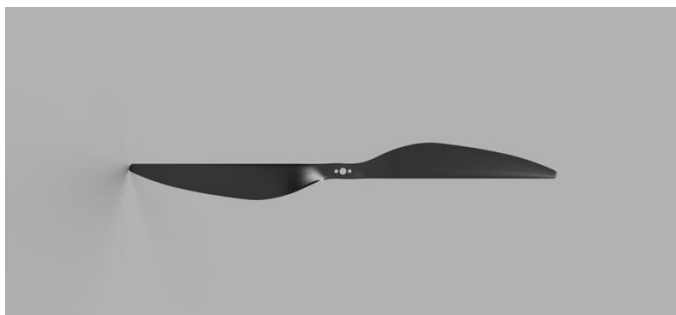

Fig.13: Propeller CAD image

5.3. MOTOR:

It is the main component that is responsible for the rotation of propellers. It can generate variable torque with high performance and more flexible in speed. As per the thrust requirements, each motor having a maximum power of 28 kW are suitable and has a kV rating of 29. That weighs about 5 kg. Using such four motors gives the best results. Also, the motors used are U15 XXLKV29 manufactured by T-motor Company. Hence one can readily use these kinds of motors if looking for manufacturing. Reasons for selection-

1. Reduced noise.
2. Longer lifetime.
3. Low maintenance.
4. Higher torque to weight ratio.
5. Increased reliability.
6. No air pollution.
7. Less maintenance.
8. Easy to connect to electronic systems.

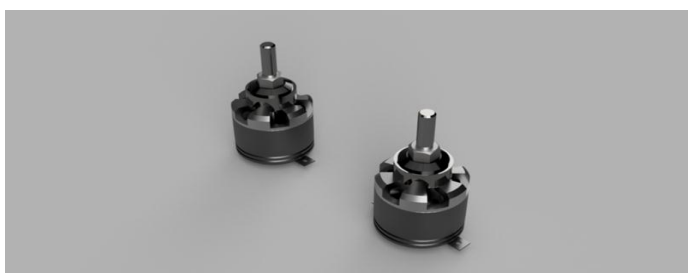

Fig.14: Electric motors

5.4. BATTERY:

In today's scenario, internal combustion engines are on the way to extinction because of its noise, weight, and pollution. So the best alternative for that is electric batteries and motors, as this works smoothly and efficiently. Lithium polymer batteries are suitable for hoverbike. This battery consists of several cells, each cell of lithium polymer having a capacity of 4.2 V. Hence the achieved output is 100 Volt per motor by several combinations of batteries. According to the motor specifications and required power, we can design a battery system in which cells are arranged in series and parallel manner to give the desired output.

Reasons to select a lithium-polymer battery-

1. These are rechargeable batteries.
2. Light in weight.
3. Safe to use.
4. Made almost any shape and size.
5. Robust and flexible.
6. Low chance of a leak of electrolyte.

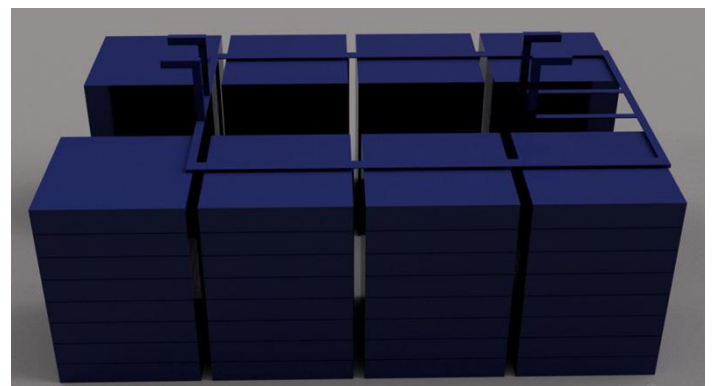

Fig.15: Battery pack

5.5. EMERGENCY SYSTEMS:

This is different than safety features because it is only meant for emergency situations. This will help to save the user's life in emergencies.

5.5.1. Kill Switch:

This is a kind of main switch for the vehicle which will cut all the electrical and electronics connections. Suppose any kind of smoke or fire is detected by the driver, he can manually hit this switch to cut down the power and can leave the vehicle by seat ejection.



Fig.16: Kill switch

5.5.2. Seat ejection system:

This feature is added because if the vehicle is not in condition for controlling or no place for landing, then the driver needs to stay away from the vehicle for avoiding any further circumstances. In airborne situations when the driver presses the kill switch seat will eject automatically with the driver.

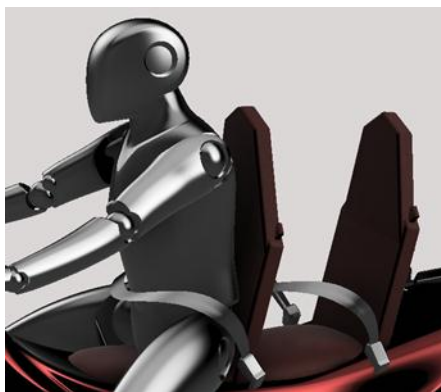

Fig.17: Seat ejection system embedded within seats.

5.5.3. Rapid Inflating Parachute:

This feature is fitted inside the ejecting seats. When the seat gets ejected parachute will inflate. And the driver gets safely landed on the ground.



Fig.18: Inflating parachutes inside the seats.

5.5.4. SOS emergency systems:

To create real-time safety information appear on your Google map in an emergency. The Google map will detect your location and give a visual display of where to go and how to get there. It sends message and emergency call to

contacts added by the user for time of emergency. This will initiate whenever you press the kill switch.

5.6.1. PDB (Power Distribution Board): As the name suggests it will distribute power all across the electronic components, motors from the battery. This component of an electric supply system divides an electrical power feed into subsidiary circuits while providing a protective fuse or circuit breaker for each circuit in a common enclosure.

5.6.2. ESC (Electronic Speed Controller): Our vehicle concept is completely electric, we need an electronic speed controller for controlling the speed of motors. It will also provide the reversing of the motor and dynamic braking. It follows a speed reference signal and varies the switching rate of the network of field-effect transistors. Inputs from throttle lever, joystick, or other manual inputs. By adjusting the duty cycle or switching frequency of transistors, the speed of the motor is changed. This is essential for turning and lifting of the vehicle in the air.

5.7. SAFETY FEATURES:

This is the most important factor in every vehicle. We provided some new and advanced tech for the safety of the user. These features will avoid emergencies.

5.7.1. Radar:

This tech is commonly used in several vehicles and with different formats and updates. It has a good range of diameter 22 meters. This is an active electronically scanned array radar technology for better obstacle detection.



Fig.19: Radar module

5.7.2. Lap belts:

These are a special type of belts that are tied up to the driver's thighs and waist. This is used for tying up the user with seating for safety from falling down.



Fig.20: Lap belts

5.7.3. Multi-information display (MID):

We included this feature in safety because we didn't give any infotainment system but we give it for updating the information regarding GPS, battery percentage, flight time, altitude, next station, weather, radar details, flight time left, etc. It shows the next upcoming charging point for charging the vehicle on a long trip. Every necessary data is displayed here. This type of screen is necessary especially in flying vehicles so that the driver/pilot can stay in contact with the hub/central control system situated on land/earth surface.



Fig.21: MID

5.7.4. Gyroscope:

This feature is provided for stabilizing the vehicle in the air in any condition.

5.7.5. Electronic damage control:

This feature added for detecting any malfunctioning of any electronic component in the vehicle and this will show it on the display board.

5.7.6. Safety kit:

Safety is the priority. In case of emergency or any accidental case for safety purposes basic kit is required with the driver which includes jackets, pants, gloves, knee braces, neck braces, chest protection, helmet. This kit ensures the driver's safety and helps to avoid any serious damage or injury to the driver.



Fig.22: Safety kit

6. WORKING PRINCIPLE:

The primary standard behind the working of this new variety of the vehicle is the Third Law of Motion and Principle of Torque [3]. A Hover Bike is a kind of vehicle that utilizes rotating wings called Blades to fly. To fly, an item should have a "lift," a power moving it upward. Wings are

bent on top and compliment on the base. This shape is called an Airfoil. That shape makes wind stream over the top quicker than under the base. Therefore, there is less air pressure on the head of the wing [1]. The ascending motion or take off and descending motion or landing is achieved by varying speed of the propellers relative to each other.

The turning mechanism or yaw is based on the principle of Torque. The front end assembly of 2 motors is connected to a servo motor that flips the assembly in the right or left direction which results in a yaw. But at the same time, the rear end assembly is flipped with the same angle but in opposite direction. As the Torque principle says, when 2 equal but opposite forces act coaxially, a turning effect gets generated. As the propeller rotates, the blades start to push the air downwards which uplifts the rotors which lead to take-off. This is the fundamental thought behind the lift, which comes down to controlling the upward and descending power. The quicker the rotors spin; the more noteworthy the lift, and vice versa [5].

This vehicle can perform these things-

1. Ascend/ take-off and descend/land.
2. Hover.
3. Yaw or turning.

7. HOVERING AND TURNING:

7.1. Ascend/ take-off and descend/ land:

Propellers are connected to the electric motors and electric motors are powered by batteries. When the propellers fitted with the ducting mechanism start to rotate; a high-pressure area gets produced below the blade and at the same time, a relatively low-pressure area is generated above the blade. This generates an upward force called Lift on the rotor blades; which further results in pushing up the whole vehicle into the air as the pressure exceeds the weight of the vehicle. There is a simple rule which states that, if the Lift is greater than the weight; the vehicle takes off. Similarly, if the Lift is lesser than the weight, the vehicle will descend or starts to land. And when the lift is exactly equal to the weight of the vehicle; the vehicle will hover into the air. P1 and P2 must rotate in opposite directions of each other. That is, if P1 is rotating in a clockwise direction, P2 must rotate in anticlockwise. Similarly, P3 and P4 follow the same pattern. Also, P1 and P3 should rotate in opposite direction.

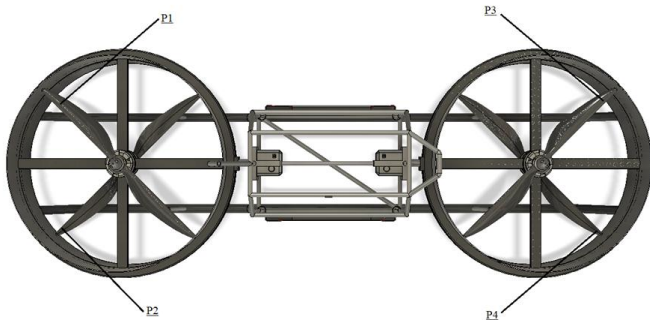

Fig.23: Take-off and land mechanics.

7.2. Hover:

7.2.1 To move ahead:

To achieve this goal, just increase the RPM of rear propellers and decrease the RPM of front propellers. So, the vehicle will start to travel in a straight forward direction as shown in the figure below. The driver can manually apply more force on the front side to get a fast reaction and forward motion. In short, reduce the RPM of P1& P2; increase the RPM of P3& P4.

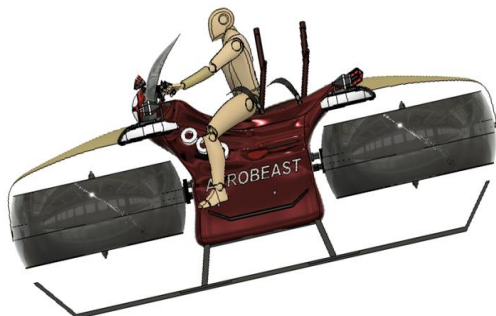

Fig.24: To move forward/ ascend

7.2.2 To descend:

To achieve this goal, exactly the opposite action has to be taken. When the RPM of rear propellers is reduced and front propellers' RPM is increased, an immediate speed reduction is obtained and the vehicle starts to hover in the mid-air as shown in the figure below.

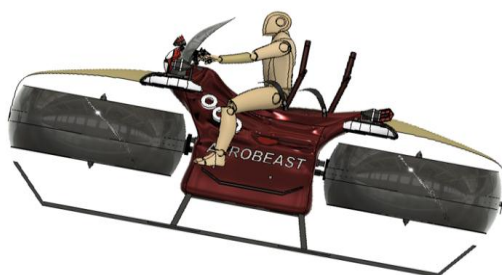

Fig.25: Descend or to hover

7.3. Yaw/turning:

7.3.1. To take a right turn:

The torque mechanism is used to achieve yaw. To have a right turn the driver just needs to turn the steering in the right direction. The front assembly of motors, duct, and propellers is connected to a servo motor which flips the whole assembly in the right direction by around 15 degrees. And at the same time, the rear assembly gets a flip by the same angle but in the left direction. So that the principle of torque gets applied and the vehicle takes a right turn.



Fig.26: Yaw mechanism- right direction turn

7.3.2. To take a left turn:

In the same way, when the steering is turned in the left direction, then the front assembly gets a flip in the left direction by 15 degrees and at the same time, the rear assembly gets a flip by the same angle but in opposite direction. Hence the principle of torque gets applied and a left turn can be obtained.



Fig.27: Yaw mechanism- left direction turn

8. APPLICATIONS:

1. The vehicle can be used to provide medical emergency help to the soldiers in critical times.
2. Transportation becomes easy without wastage of time in traffic problems and road travelling.
3. It can be used for monitoring the border areas and for food deliveries on the ships for Navy soldiers.

4. It can be used for providing rescue missions to carry out the people affected by flood, tsunamis, fire rescues, etc.

5. It is a great option for the military missions and trainings.

9. ANALYSIS AND AIRFLOW SIMULATION:

The frame is made of Aluminium AlSi10Mg which supports the whole vehicle and joins propeller supporters to the main body. Aluminium AlSi10 mg has density 0.003 g/mm³. The yield strength of this material is 240 Mpa and the Ultimate tensile strength is 460 Mpa. The following tables and screenshots of analysis shows the results,

Aluminum AlSi10Mg	
Density	2.67E-06 kg / mm ³
Young's Modulus	71000 MPa
Poisson's Ratio	0.33
Yield Strength	240 MPa
Ultimate Tensile Strength	460 MPa
Thermal Conductivity	0.165 W / (mm C)
Thermal Expansion Coefficient	2.1E-05 / C
Specific Heat	880 J / (kg C)

Displacement
Total [mm] 0 to 1.564

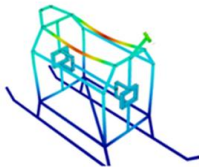

Result Summary		
Name	Minimum	Maximum
Safety Factor		15
Safety Factor (Per Body)	6.674	
Stress		
Von Mises	0 MPa	27.67 MPa
1st Principal	-10.73 MPa	29.05 MPa
3rd Principal	-34.88 MPa	7.118 MPa
Normal XX	-32.61 MPa	26.3 MPa
Normal YY	-23.54 MPa	25.22 MPa
Normal ZZ	-24.4 MPa	20.39 MPa
Shear XY	-7.495 MPa	7.838 MPa
Shear YZ	-8.311 MPa	9.601 MPa
Shear ZX	-12.44 MPa	12.03 MPa
Displacement		
Total	0 mm	1.564 mm
X	-0.8558 mm	0.00197 mm
Y	-0.4521 mm	0.4513 mm
Z	-1.499 mm	0.1406 mm
Reaction Force		
Total	0 N	452.8 N
X	-110.9 N	91.81 N
Y	-381.1 N	381.1 N
Z	-148 N	228.5 N
Strain		
Equivalent	0	5.988E-04
1st Principal	-9.612E-12	5.793E-04
3rd Principal	-6.213E-04	6.48E-12
Normal XX	-3.682E-04	3.487E-04
Normal YY	-3.207E-04	2.436E-04
Normal ZZ	-2.873E-04	2.37E-04
Shear XY	-2.808E-04	2.936E-04
Shear YZ	-3.114E-04	3.597E-04
Shear ZX	-4.66E-04	4.508E-04

Fig-5: Schematic view of frame analysis

Fig.28: Obtained results from the analysis

Flow Simulation :

The software used for simulation is 'Autodesk flow simulation'. Flow simulation for finding out only drag and drag coefficient. For 3D analysis, Drag coefficient = 2.57, Avg. drag coefficient = 5.1, Drag force = 101.39(lbs). For 2D analysis, Drag coefficient = 0.51, Avg. drag coefficient = 0.51, Drag force = 35.38(lbs).

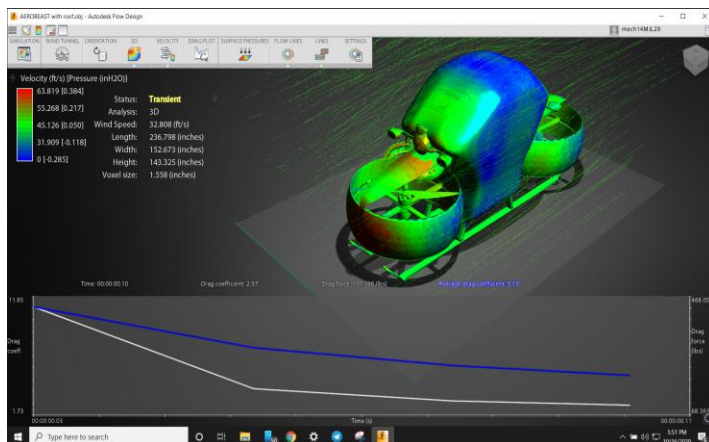

Fig.29: Schematic view of flow analysis (3D).

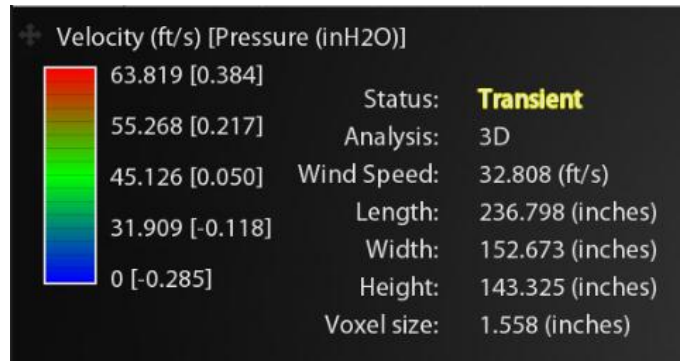

Fig.30: 3D analysis details.

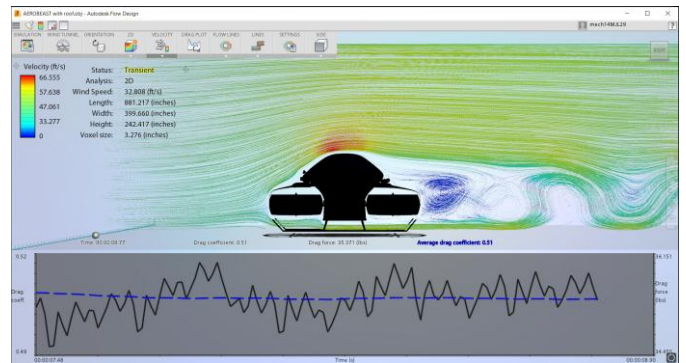

Fig.31: Schematic view of flow analysis (2D).

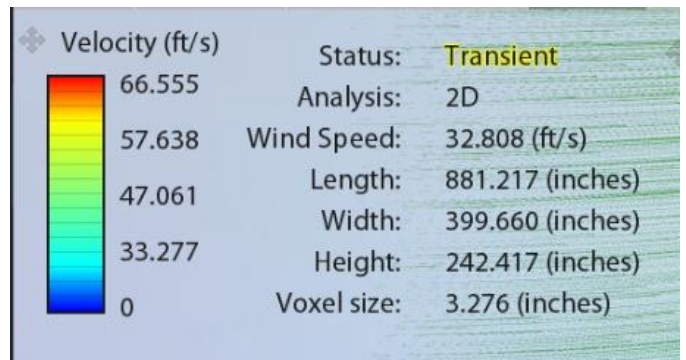

Fig.32: 2D analysis details.

10. ADVANTAGES:

1. No traffic problem.
2. Ability to take off and land vertigo. So it can hover in critical areas.
3. No need of runways.
4. It is completely electrically powered so the air pollution is reduced and it's a good initiative towards saving the environment.
5. One can travel over the sea, lakes, rivers to provide help and food during critical times.
6. It is an excellent technology for emergency rescue, military purpose etc.

7. it's a key to the future of personalized aviation.

11. DISADVANTAGES:

1. Initial cost is high.
2. It can fly up to 100 feet only.
3. At a time only two passenger can seat on the vehicle.

12. FUTURE SCOPE:

Future developments and applications of air vehicle are:

1. To make it capable of carrying 4 persons.
2. To increase the altitude of the vehicle beyond 100 feet.
3. To increase the flight time by 2 hours for more traveling.
4. Trying to provide more safety features to ensure more and more safety.
5. We are bounded by the technological stuff right now, but once high power batteries get created, a huge revolution will happen in the field of aviation.

13. CONCLUSION AND DISCUSSION:

Personalized flying has been the dream of mankind for a long time. This project could fulfill this dream. Proper calculation, advanced programming, best manufacturing techniques like 3D printing, simulations, analysis, and excellent CAD modeling makes this project unique and creative. The achievable flight time is 1 hour with 2 persons. The total amount of thrust generated is 470Kgs which is sufficient to carry 2 persons and an extra load/payload of 30 Kgs. We successfully achieved the total weight as 121 Kgs (without the drivers) and with 2 persons/drivers, it goes around 231 Kgs. The maximum speed of the vehicle is 30 Km/hr. The shape of the bike and sitting posture is like a bike; hence it is really easy to drive and would be familiar to everyone. The motors used are U15 XXLKV29 manufactured by T-motor company; hence the motors are easily available. The vehicle is completely electrically powered and hence it is committed to the environment because there would be no pollution by the vehicle. The centralized autopilot system is really important to embed a smart control system to regulate and control components of the vehicle. This system consists of Gyroscope, accelerometer, GPS, ESE, PDB, etc. It is capable to achieve a height of 100 feet from the ground with quick take-off. It has a radar system that has a range of 22-meter diameter. The lap belts, mini-parachute, and safety kit make this product safer. The full-screen display shows every necessary parameter.

This is a truly compact and personalized flying machine with the best safety features and modern technologies. A safe and secure flight is really important when it comes to aircraft or aviation vehicles and this vehicle is comprised of all of them. The future of personalized aviation is not so far.

14. REFERENCES:

- [1] Naware, Abhay. "STUDY OF CONSTRUCTION AND WORKING OF HOVER BIKE." *Int. Reseach J. of Engineering and Technology* 5, no. 5 (2018): 4287-4293.
- [2] Patil, Ninad R., and Ashish A. Ramugade. "Design Analysis of Hoverbike Prototype." *International Journal for scientific research & development* 5, no. 2 (2017): 1061-1065.
- [3] Carpenter, Umesh, and Nitin Rathi. "Design and Development of Hover bike." (2017): 61-65.
- [4] B.Madhan Kumar, Prof.M.Sathish Kumar, "Flying Hover Bike, A Small Aerial Vehicle For Commercial Or Surveying Purposes", *IJSER*, Volume 4, Issue 7, July-2013, ISSN 2229- 5518, (PN:485-488)
- [5] <https://www.dronetrest.com/>
- [6] Prakash, M., Shaik, N.U., Nagaveni, R., Padmavathi, L. and Khan, M.A., 2017. Solar Powered Hover Board for Future Individual Transportation. *Perspectives in Communication, Embedded-systems and Signal-processing-PiCES*, 1(5), pp.61-62.
- [7] Dhakad, A.S. and Singh, P., 2014. Flying bike concept. *International Research Journal Of Mechanical Engineering*, 1, pp.001-011.
- [8] Intwala, A., 2015. Design & Analysis of Vertical Takeoff and Landing Vehicle (VTOL). *International Journal of Applied Engineering Research (IJAER)*, Research India Publications, 10(11), pp.28955-28962.
- [9] Lewis, S.D., Shiri, N.D., Vikesh, K., Olivera, S.C., Konde, V. and Dsouza, P.C., 2016. Fabrication and Testing of Scaled Prototype of Hoverbike. *Journal of Mechanical Engineering and Automation*, 6, pp.71-74.