

MODELING AND ANALYSIS OF ALUMINIUM ALLOY AUTOMOTIVE WHEEL RIM

Madhusudhan R¹, Dr. B. Sadashive Gowda²

¹M.Tech Scholar, Vidyavardhaka College of Engg, Mysuru, Karnataka, India.

²Principal, Vidyavardhaka College of Engg, Mysuru, Karnataka, India.

Abstract - The purpose of the automotive wheel rim is to provide a firm base to suit the tyre. Its dimensions and shape should be appropriate to adequately accommodate the actual tyre needed for the vehicle. In automobile industries aluminium is utilized for producing of wheels and different parts of vehicles. The main advantage of aluminium is less weight and high strength. The steel wheel replaced by aluminium wheel because of its physical and chemical property. The wheel rim is modelled by utilizing the CATIA software. By utilizing this software, the time spent in producing the complex 3-D models and the risk involved in the design and manufacturing process can be easily minimized. Later the CATIA model is imported to ANSYS for analysis work. ANSYS software is used for simulating the various forces applied on the part and also calculating and viewing the results. Using FEA (finite-element-analysis), static structural and fatigue analysis work carried out by considered two different materials namely aluminium alloy A356.2 and aluminium alloy 6061 and their comparative performances are observed individually.

The analysis undergoes both inflation pressure and vertical loading conditions. In these loading conditions static structural and fatigue analysis are considered. In static structural analysis, when the load is applied on the rim we find out the total deformation, equivalent stress, safety factor and stress ratio by using FEA (finite-element-analysis) software. In fatigue analysis, by utilizing S-N curve approach we also find out the fatigue life, safety factor, damage, biaxiality indication and equivalent alternating stress of wheel rim.

Keywords: Automotive wheel rim, Catia, Finite element analysis, Aluminium alloy A356.2, Aluminium alloy 6061, Static structural analysis, Fatigue analysis, S-N curve etc.

1. INTRODUCTION

A few thousand years ago, became the beginning of the historical backdrop of wheel when the humankind started to utilize the log to transport or move heavy objects or things. The origin of the wheel were the round cuts of a log and it was slowly reinforced and utilized in this structure for hundreds of year on carts. This solid disc modified to a structure having few spokes radially organized to help the external part of the wheel keeping it in between from the center of wheel.

The hard wood stakes as spokes which used in a wooden wheel, became extremely well as a wheel for numerous automobiles up to approximately 1920. Later the disc wheel, wherein the spokes were switched with a disc made of steel plate, was presented and is yet being utilized right up till today. Besides, a light alloy has come to be utilize presently as a wheel material for some kinds of vehicles. Trucks have been the basic support of the world's workforce for decades. It must be powerful, big, and can certainly get you through the terrains. But a truck cannot do its job without properly operating of wheels. Truck rims need to be modified if they are bent or cracked for the sake of truck's life. Most steel truck wheel rims are made in the identical way and it begins with a hard cast hub, with four, five or even six holes for the bolts. The rim is accurately balanced and then given a clean finish. Although few steel rims are available in silver, a large portion of those completions are put something aside for alloy wheels. Truck wheels need to be long lasting and be able to carry around weight. We won't find many spokes design with these rims. It should normally as strong as possible. But that doesn't mean, the options are not diverse when looking for substitutions. The most essential issue not to forget is to purchase the same rim sizes that are replacing except if and we are also interested on vehicle modifications.

1.1 WHEEL/RIM DESCRIPTION

Wheel is main structural member of the automotive vehicles that supports the static structural and radial loads come across during automobile movements. Since the rim is most important elements in a vehicle, on which cars move, so it must be structured cautiously

The wheel rim is circular in design at outer, on which the inside edge of the tyre is mounted on vehicles. A regular automotive vehicle wheel rim is produced using a square or rectangular sheet plates. The square or rectangular steel plate is twisted to provide a cylindrical sleeve with the two free edges and the free edges of sleeves are welded together. In any case, one cylindrical go along with the drift turning process is done to acquire or gain a specified thickness shape of the sleeve in specially including within the region projected to establish the external seat at an angle of inclination relative to axial path. Then fashioned the sleeve to acquire the rims on each side with a radially inner cylindrical partition in the region of external seat. The rim is the part of automobile, wherein it extensively experiences each radial

loads as well as fatigue loads, when the wheel rim travels totally altered road profiles. This will cause the develop of significant stresses in rim therefore we have to discover the essential point of stress and number of cycles that the wheel/rim is going to fail. Wheels are produced by wire spoke, steel disc or light alloy wheels. Light alloy wheel involves magnesium or aluminium or titanium alloys. Aluminium is the alloys of material with features of corrosion resistance, excellent lightness and thermal conductivity etc. Especially, the rims are produced by aluminium casting alloys or magnesium casting alloys. Aluminium alloy wheels are more desirable due to its features and their properties.

2. METHODOLOGY

2.1 STEPS INVOLVED IN METHODOLOGY

1. Modeling of Automotive wheel rim
2. Inputs for Finite element analysis
 - a. Designed/allowable vertical load
 - b. Finding inability of wheel rim to sustain load
 - c. Finding radial load for fatigue analysis
3. Finite element (static and fatigue) analysis of Automotive wheel rim.
 - a. Finite Element Modeling
 - b. Applying boundary conditions
 - c. Loading condition
 - i. Constant tire inflation pressure
 - ii. Designed load
 - iii. Radial load
 - iv. Fatigue load (Alternating stress)
4. Results
 - a. Stress and displacement plot for constant tire inflation pressure and radial load.
 - b. Fatigue life prediction using the stress approach.
5. Study of inflation pressure effect on the state of stress

2.2 WHEEL RIM NOMENCLATURE

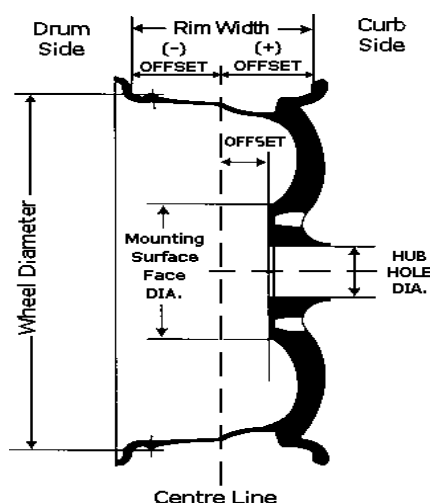

Figure 2.1: Wheel Rim Nomenclature

2.3 Wheel Rim Dimension

Rim Diameter	406.4mm
Rim Width	177.8mm
Hub Hole Diameter	51mm
Bolt pattern (Pitch circle Diameter)	115mm
Bolt pattern (Number of bolts)	4
Offset	41mm

Table 2.1: Dimensions of 3D Model of Wheel Rim

2.3 MODELING OF WHEEL

In advanced domain, the projects, designs, manufacturing, improvement, etc., that we cannot imagine deprived of interfering the computers. Computers are the integral-part of the above mentioned areas. Nowadays, on marketplace the competitions in not only price aspect however it likewise in superiority, quantity, constancy, reliability, accessibility, stuffing, carrying, transport and so on. These are the necessities pushing industry towards undertaken the contemporary method in performance and pushing industry towards familiarize best strategies namely CAE/CAD/CAM and so on. Probable fundamental approach to the industry is to create a great exceptional product at minimum charges through the use of computer-Aided-Engineering [CAE], Computer-Aided-Design [CAD] and Computer-Aided-Manufacturing [CAM] systems.

The CATIA is a software, it utilized to create and modify the model, object and things. In this software, the designing and modelling features are presented. Designing means the procedure carried out to create the new model or modify the existing model. Modelling means create and transforming from 2-dimension to 3-dimension. The 3-dimension model of wheel rim is designed by utilizing CATIA software.

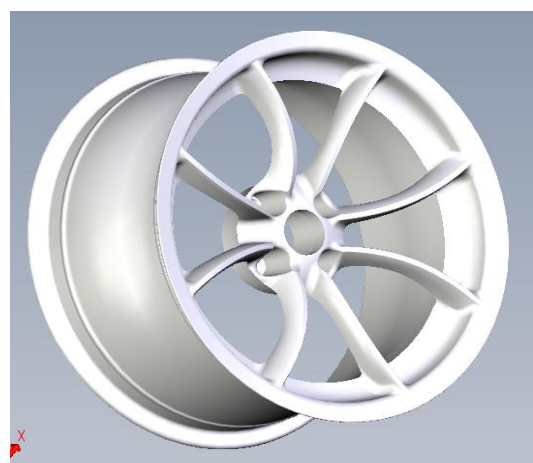

Figure 2.2: Isometric View of Wheel Rim

2.4 GENERATING THE MESH USING ANSYS SOFTWARE

The Ansys meshing is the great concert of finite element preprocessing and post-processing, and allow the

manufacturer towards analyzing the object design concerts in particularly cooperating and visual-atmosphere. Ansys mesh operator-interface, it should be easy to analyze and provisions for some CAD and finite-element-model documents rising its performances. Progressive capability inside the mesh permits operator towards successfully mesh the extreme fidelity objects. These capability consists of operator to describe the standard conditions in addition to control, transforming method towards apprise the current mesh to new-design proposition and programmed mid surface technology is used to complicated design through changing the partition thickness. Programmed mesh reduces the time of meshing, concurrently batch-mesh permits huge gauge meshing of component with minimum operator effort.

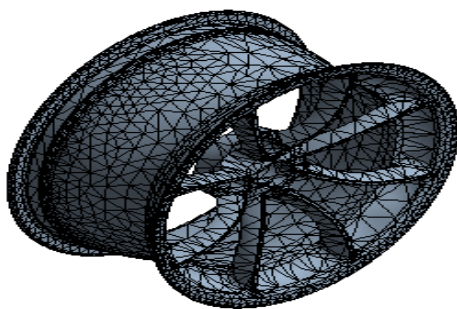

Figure 2.3:- Meshing Model of Wheel Rim

2.5 PROPERTIES OF MATERIALS

	Aluminium Alloy A356.2	Aluminium Alloy 6061
Ultimate Tensile Strength	250MPa	310MPa
Tensile Yield Strength	230MPa	276MPa
Young's Modules	72.4GPa	68.9GPa
Poisson's Ratio	0.33	0.33
Density	2810kg/m ³	2770Kg/m ³
Thermal Expansion	1.2e5 1/°C	2.3e5 1/°C

Table 2.2: Properties of Materials

2.5.1 Composition of Materials

2.5.1.1 Composition of Aluminium Alloy A356.2

Elem-ents	Si	Mg	Ti	Fe	Cu	Zn	Al
Weight in [%]	6.5-7.5	0.24-0.45	0.07-0.20	0.15	0.10	0.08	Remaining (91.25-92.25)

Table 2.3: Composition of Aluminium Alloy A356.2

2.5.1.2 Composition of Aluminium Alloy 6061

Elem-ents	Si	Mg	Ti	Fe	Cu	Zn	Al
Weight in [%]	0.4-0.8	0.8-1.2	0.08-0.25	0.7	0.15-0.40	0.1-0.25	Remaining (95.86-98.56)

Table 2.4: Composition of Aluminium Alloy 6061

2.6 FINITE ELEMENT ANALYSIS

The finite-element method generate several instantaneous algebraic-equations, that are created and resolved by using a computer. Finite-element-method was invented by means of the technique to analyze the stresses. Finite-element-method has decisively hooked up by way of popular and effective analyzing-tool. This is the mathematical manner for evaluating the structure. The Finite-element process is utilized for the design of heat engine, building, ship, space crafts and so on. In finite-element-analysis, the static structural analysis and fatigue analysis are carried out.

2.7 STRUCTURAL ANALYSIS:

The extreme application of FEM(finite-element-method is stress-analysis). The time period structure infers not limited to civil-engineering structure like constructions and channels, it as well as implies mechanical structures, aerospace and marine. The mechanical structure include aircrafts, marine bodies, machines casing and its frames, in addition to motorized additives like pistons, machines fragment, tools and equipment's.

2.7.1 Static Analysis

Static analysis determines influence of regular loading condition on the structures, at the same time ignoring inertia and damping consequences, including the ones because of time-variable loads. The static analysis, on the other hand it consists of constant inertia loads(inclusive of rotating-

velocity and gravity), and time-variable masses could be similar to static correspondent load (together with static-equivalent air in addition to seismic load typically established in several buildings code). Static evolution includes in cooperation of linear and non-linear analysis. Non-linear could encompass elasticity, plasticity, stress-hardening, deflection, strain, stability and interaction surface.

Finite-element analysis is utilized for significant portion of these work is static analysis, it includes in co-operation of linear and non-linear analysis. Later additional importance remains conveyed to linear and non-linear examination carried on remaining segments.

2.8 FATIGUE ANALYSIS

The essential features, which lies under particular fatigue-damage mechanism is the presence of rehashed or cyclic-stress at any point of an object. It must be consider as fundamental meaning of fatigue. Repeated or rehashed stresses sensor strain gave the starting point of failure accretion till that grows into the crack, it lastly lead towards the damage of object.

3. RESULTS AND DISCUSSION

3.1 STATIC STRUCTURAL ANALYSIS:

The maximum stress and deformation of the structure or a component due to load acting on that, in static condition can be accomplished by Static-Analysis. The types of load which can be applied in a static analysis are pressure, force and temperature, which are applied externally, and angular velocity at static condition.

■ STATIC STRUCTURAL ANALYSIS, WHEN THE RIM SUBJECTED TO INFLATION PRESSURE:

Loading and constraints:

Fixed support: The wheel rim model is constrained at all four bolt holes.

- **Wheel Constrained at 4 Bolt Hole (Fixed Support)**

A: Wheel Rim Subjected to Inflation Pressure
Figure
Time: 1. s
6/15/2020 1:08 PM

■ Fixed Support

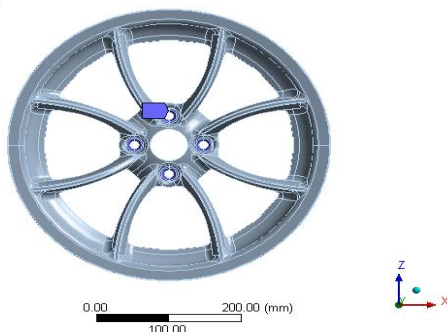

Figure 3.1 : Wheel Constrained on 4 Bolt Hole

- **Inflation-Pressure Applied on Outer Circumference of Rim**

A: Wheel Rim Subjected to Inflation Pressure
Figure
Time: 1. s
6/15/2020 1:08 PM

■ Pressure: 0.24821 MPa
Components: 0, 0, 0. MPa

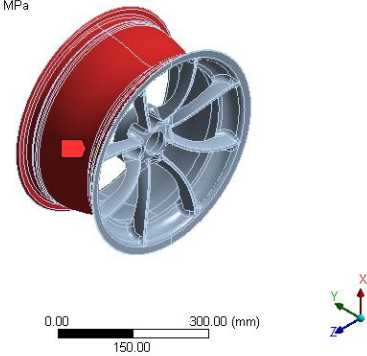

Figure 3.2: Inflation Pressure Applied on Outer Circumference of Rim

In circumstance of pressure-stacking, the pressure of 0.24821MPa is applied to circumference of wheel rim, and all the bolts are constrained aimed at 6 degree of freedom.

Tyre Air Pressure:

For typical conditions, the 35 Psi is the regular inflation pressure setting. The 35psi is equivalent to 0.24821Mpa of pressure and it is applied around the outside circumference of wheel rim.

3.1.1 Static Structural Analysis of Aluminium Alloy A356.2 Wheel Rim, When the Rim Subjected to Inflation Pressure:

- **Total Deformation:**

A: A356.2 Alloy Wheel Rim Subjected to Inflation Pressure
Figure
Type: Total Deformation
Unit: mm
Time: 1
7/12/2020 12:20 PM

■ 0.13007 Max
0.11562
0.10116
0.086712
0.07226
0.057808
0.043356
0.028904
0.014452
0 Min

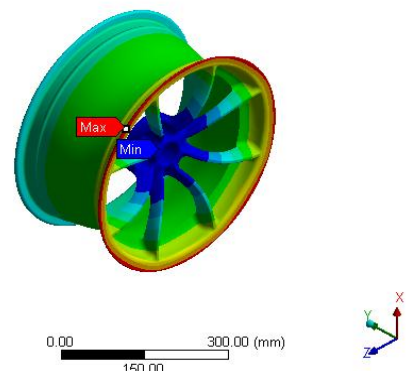

Figure 3.3: Total Deformation of Aluminium Alloy A356.2 Wheel Rim

• **Equivalent(Von-Mises) Stress:**

A: A356.2 Alloy Wheel Rim Subjected to Inflation Pressure
 Figure
 Type: Equivalent (von-Mises) Stress
 Unit: MPa
 Time: 1
 7/12/2020 12:20 PM

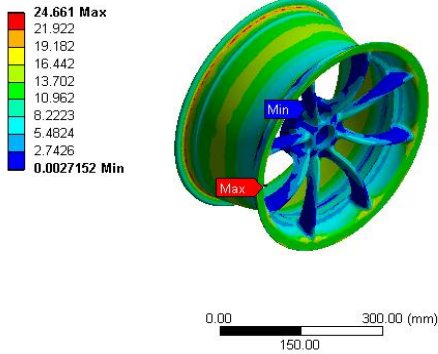

Figure 3.4: Equivalent(Von-Mises) Stress of Aluminium Alloy A356.2 Wheel Rim

• **Stress Ratio:**

A: A356.2 Alloy Wheel Rim Subjected to Inflation Pressure
 Figure
 Type: Stress Ratio
 Time: 1
 7/12/2020 12:21 PM

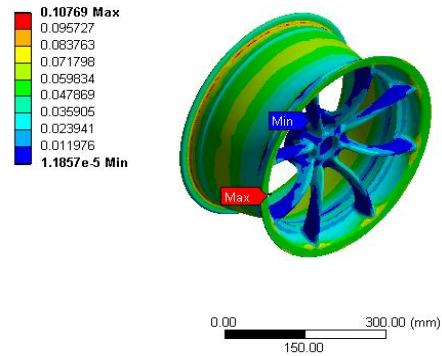

Figure 3.7: Stress Ratio of Aluminium Alloy A356.2 Wheel Rim

• **Stress intensity:**

A: A356.2 Alloy Wheel Rim Subjected to Inflation Pressure
 Figure
 Type: Stress Intensity
 Unit: MPa
 Time: 1
 7/12/2020 12:20 PM

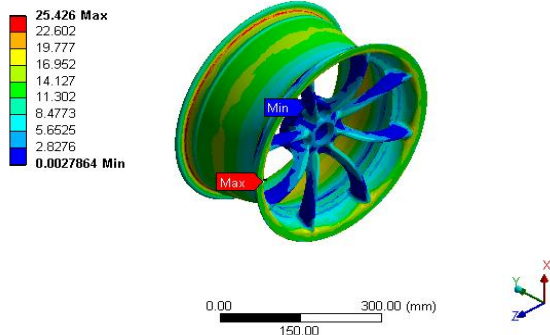

Figure 3.5: Stress Intensity of Aluminium Alloy A356.2 Wheel Rim

• **Safety Factor:**

A: A356.2 Alloy Wheel Rim Subjected to Inflation Pressure
 Figure
 Type: Safety Factor
 Time: 1
 7/12/2020 12:20 PM

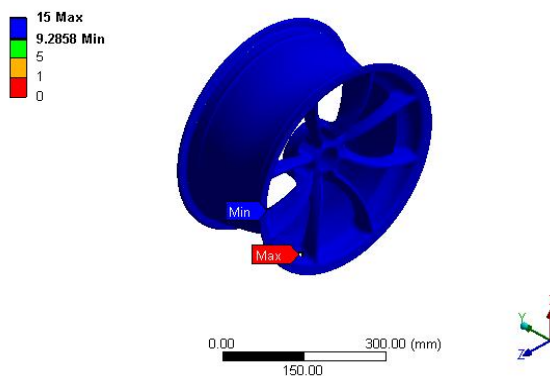

Figure 3.6: Safety Factor of Aluminium Alloy A356.2 Wheel Rim

3.1.2 Results for Static Structural Analysis of Aluminium Alloy A356.2 Wheel Rim, When the Rim Subjected To Inflation Pressure:

Type	Total Deformation in mm	Equivalent Stress in MPa	Stress Intensity in MPa	Safety Factor	Stress Ratio
Min	0	2.7152e-3	2.7864e-3	9.2858	1.857e-5
Max	0.13007	24.661	25.426	15	0.10769

Table 3.1: Results for Static Structural Analysis of Aluminium Alloy A356.2 Wheel Rim, When the Rim Subjected to inflation Pressure

In static structural analysis the aluminium alloy A356.2 wheel rim subjected to inflation pressure, the pressure 0.24821MPa is applied on circumference of wheel. The minimum total deformation is 0 at hub portion and the maximum total deformation is 0.13007mm at rim area. The minimum equivalent stress is 2.7152e-3MPa at hub and maximum equivalent stress is 24.661MPa at rim. The minimum stress intensity 2.7864e-3MPa and maximum stress intensity is 25.426MPa. The minimum stress ratio 1.857e-5MPa at hub and maximum stress ratio is 0.10769MPa at rim. The safety of the wheel is maximum at hub area since the maximum load acting at rim and minimum load acting at hub.

3.1.3 Static Structural Analysis of Aluminium Alloy 6061 Wheel Rim, When the Rim Subjected to Inflation Pressure:

• **Total Deformation:**

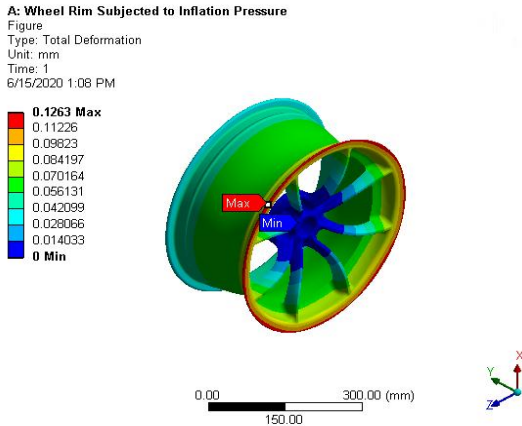

Figure 3.8: Total Deformation of Aluminium Alloy 6061 Wheel Rim

• **Equivalent(Von-Mises) Stress:**

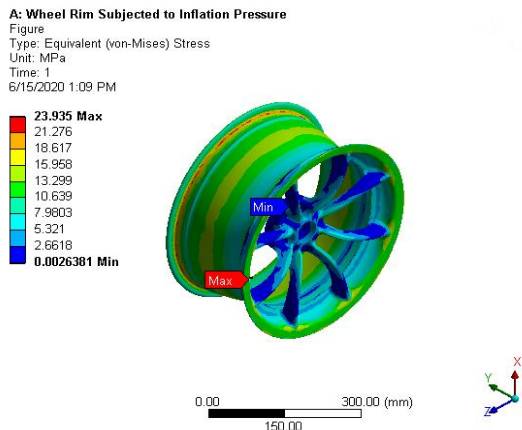

Figure 3.9: Equivalent(Von-Mises) Stress of Aluminium Alloy 6061 Wheel Rim

• **Stress Intensity:**

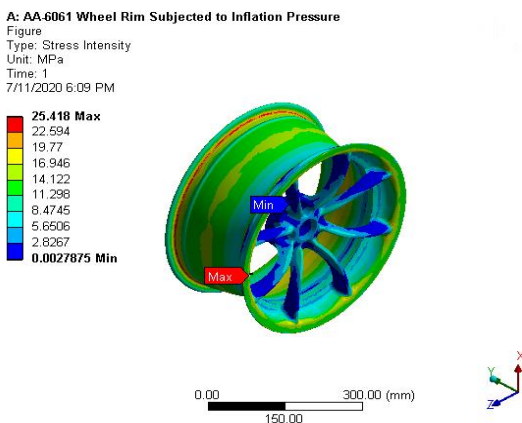

Figure 3.10: Stress Intensity of Aluminium Alloy 6061 Wheel Rim

• **Safety Factor:**

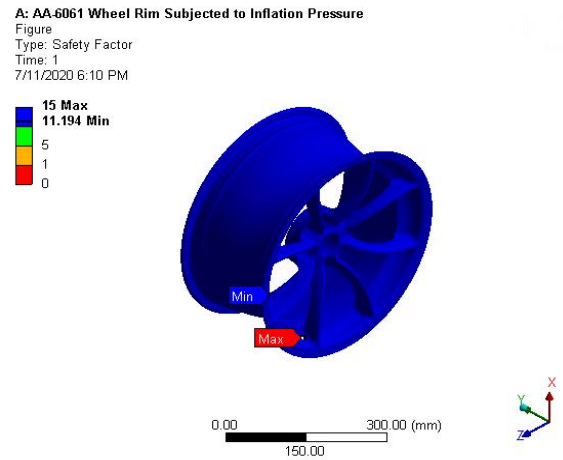

Figure 3.11: Safety Factor of Aluminium Alloy 6061 Wheel Rim

• **Stress Ratio:**

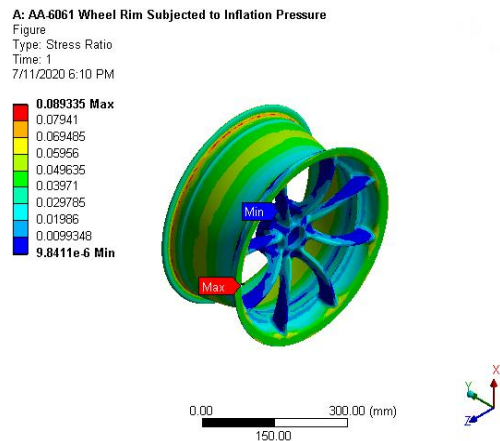

Figure 3.12: Stress Ratio of Aluminium Alloy 6061 Wheel Rim

3.1.4 Results for Static Structural Analysis of Aluminium Alloy 6061 Wheel Rim, When the Rim Subjected to inflation Pressure:

Type	Total Deformation in mm	Equivalent Stress in MPa	Stress Intensity in MPa	Safety Factor	Stress Ratio
Min	0	2.6381e-3	2.7875e-3	11.194	9.8411e-6
Max	0.1263	23.935	25.418	15	8.9335e-2

Table 3.2: Results for Static Structural Analysis of Aluminium Alloy 6061 Wheel Rim, When the Rim Subjected to inflation Pressure

In static structural analysis the aluminium alloy 6061 wheel rim subjected to inflation pressure, the pressure

0.24821MPa is applied on circumference of wheel. The minimum total deformation is 0 at hub portion and the maximum total deformation is 0.1263mm at rim area. The minimum equivalent stress is 2.6381e-3MPa at hub and maximum equivalent stress is 23.935MPa at rim. The minimum stress intensity 2.7875e-3MPa and maximum stress intensity is 25.418MPa. The minimum stress ratio 9.8411e-6MPa at hub and maximum stress ratio is 8.9335e-2MPa at rim. The safety of the wheel is maximum at hub area since the maximum load acting at rim and minimum load acting at hub.

▪ **STATIC STRUCTURAL ANALYSIS, WHEN THE RIM SUBJECTED RIM SUBJECTED TO VERTICAL LOAD:**

• **Load Applied on the Wheel Rim:**

B: Wheel Rim Subjected to Vertical Load

Figure
Time: 1 s
7/10/2020 12:41 PM

Force: 9496. N
Components: 9496.0,0.0. N

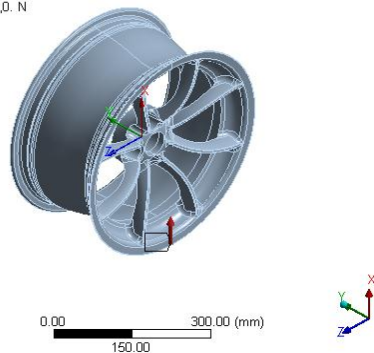

Figure 3.13: Load (Vertical Load) Applied on the Wheel Rim

In circumstances of vertical loading, the vertical load of 9496N is applied vertically from downwards. Before loading, the wheel rim model must be meshed correctly and completely constrained the degree of freedoms. The outer rim is selected through considering numerous sets, displacements are defined through nodes by consider the above recommended condition. And consider the camber angle as zero. In advance running the analysis the wheel rim must required some data, for example material properties. Vertical Load:

$$Fr = F * K$$

Where,

Fr = Radial(Vertical) load in Newton(N).

F = Maximum load applied to tyre in Newton(N).

K = Coefficient according to industry standard.

According to industry standard:

$$F=968 \text{ lbs}$$

$$F= 968 * 0.453$$

$$F= 439\text{kg} \sim 440 * 9.81 = 4316.4 \text{ N}$$

According to the industrial standards: K=2.2

Radial (Vertical) load

$$Fr = F * K$$

$$Fr= 4316.4 * 2.2$$

$$Fr=9496.04\text{N}$$

3.1.5 Static Structural Analysis of Aluminium Alloy A356.2 Wheel Rim, When the Rim Subjected to Vertical Load:

• **Total Deformation:**

B: A356.2 Alloy Wheel Rim Subjected to Vertical Load

Figure
Type: Total Deformation
Unit: mm
Time: 1
7/12/2020 12:23 PM

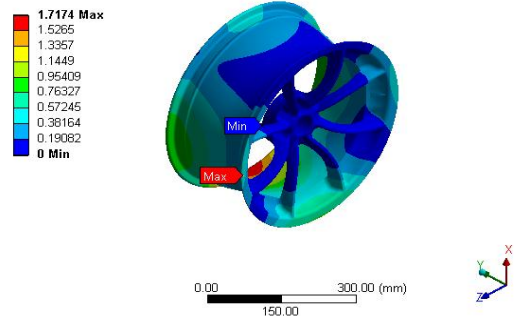

Figure 3.14: Total Deformation of Aluminium Alloy 6061 Wheel Rim

• **Equivalent(Von-Mises) Stress:**

B: A356.2 Alloy Wheel Rim Subjected to Vertical Load

Figure
Type: Equivalent (von-Mises) Stress
Unit: MPa
Time: 1
7/12/2020 12:23 PM

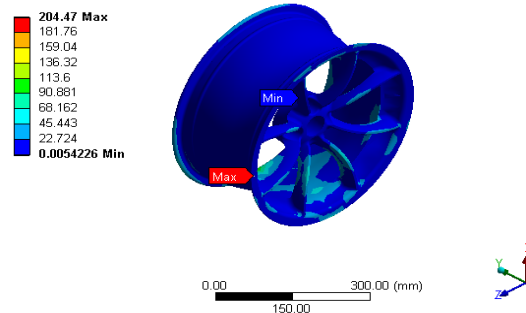

Figure 3.15: Equivalent(Von-Mises) Stress of Aluminium Alloy A356.2 Wheel Rim

• **Stress Intensity:**

B: A356.2 Alloy Wheel Rim Subjected to Vertical Load

Figure
Type: Stress Intensity
Unit: MPa
Time: 1
7/12/2020 12:23 PM

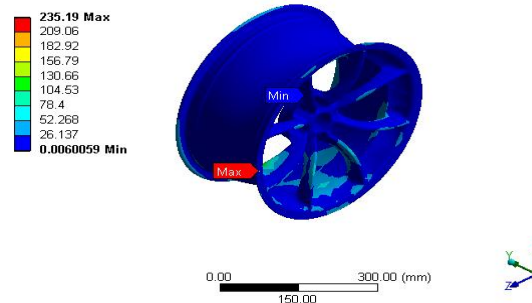

Figure 3.16: Stress Intensity of Aluminium Alloy A356.2 Wheel Rim

Safety Factor:

B: A356.2 Alloy Wheel Rim Subjected to Vertical Load
 Figure
 Type: Safety Factor
 Time: 1
 7/12/2020 12:23 PM

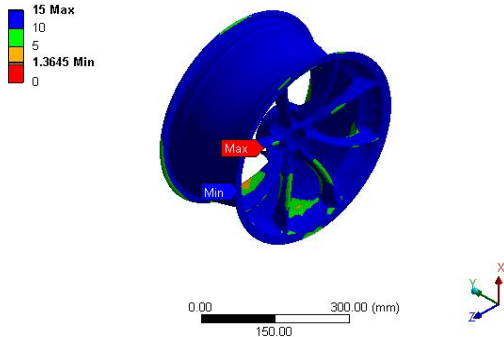

Figure 3.17: Safety Factor of Aluminium Alloy A356.2 Wheel Rim

Stress Ratio:

B: A356.2 Alloy Wheel Rim Subjected to Vertical Load
 Figure
 Type: Stress Ratio
 Time: 1
 7/12/2020 2:37 PM

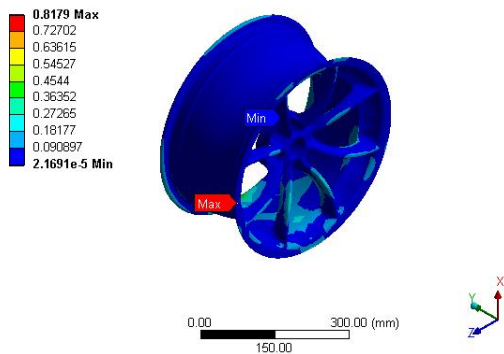

Figure 3.18: Stress Ratio of Aluminium Alloy A356.2 Wheel Rim

5.1.6 Results for Static Structural Analysis of Aluminium Alloy A356.2 Wheel Rim, When the Rim is Subjected to Vertical Load:

Table 3.3: Results for Static Structural Analysis of Aluminium Alloy A356.2 Wheel Rim, When the Rim is Subjected to Vertical Load

Type	Total Deformation in mm	Equivalent Stress in MPa	Stress Intensity in MPa	Safety Factor	Stress Ratio
Min	0	5.4226e-3	6.0059e-3	1.3645	1.9436e-5
Max	1.7174	204.47	235.19	15	0.73289

In static structural analysis the aluminium alloy A356.2 wheel rim subjected to vertical load, the vertical load of 9496N is applied vertically from downwards. The minimum total deformation is 0 at hub area and the maximum total deformation is 1.7174mm at rim portion. The minimum equivalent stress is 5.4226e-3MPa at hub and maximum equivalent stress is 204.47MPa at rim. The minimum stress intensity 6.0059e-3MPa and maximum stress intensity is 235.19MPa. The safety factor is 1.3645 and the safety margin

is 0.73289. The minimum stress ratio 1.9436e-5MPa at hub and maximum stress ratio is 0.73289MPa at rim. The safety of the wheel is maximum at hub area since the maximum load acting at rim and minimum load acting at hub.

5.1.7 Static Structural Analysis of Aluminium Alloy 6061 Wheel Rim, When the Rim Subjected to Vertical Load:

Total Deformation:

B: AA-6061 Wheel Rim Subjected to Vertical Load
 Figure
 Type: Total Deformation
 Unit: mm
 Time: 1
 7/11/2020 6:10 PM

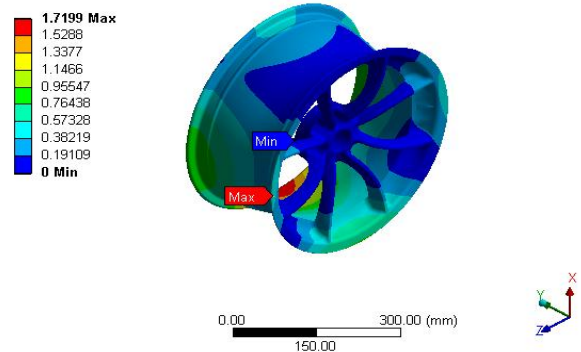

Figure 3.19: Total Deformation of Aluminium Alloy 6061 Wheel Rim

Equivalent(Von-Mises) Stress:

B: AA-6061 Wheel Rim Subjected to Vertical Load
 Figure
 Type: Equivalent (von-Mises) Stress
 Unit: MPa
 Time: 1
 7/11/2020 6:11 PM

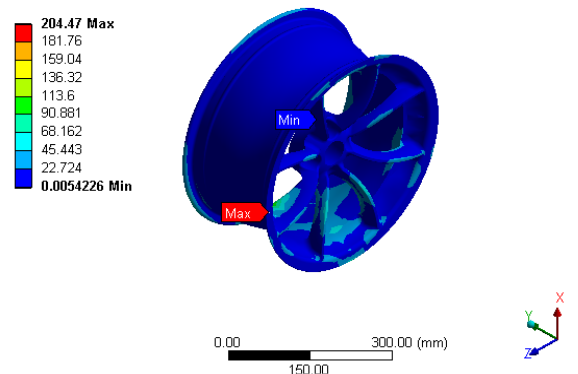

Figure 3.20: Equivalent(Von-Mises) Stress of Aluminium Alloy 6061 Wheel Rim

• **Stress Intensity:**

B: AA-6061 Wheel Rim Subjected to Vertical Load
 Figure
 Type: Stress Intensity
 Unit: MPa
 Time: 1
 7/11/2020 6:11 PM

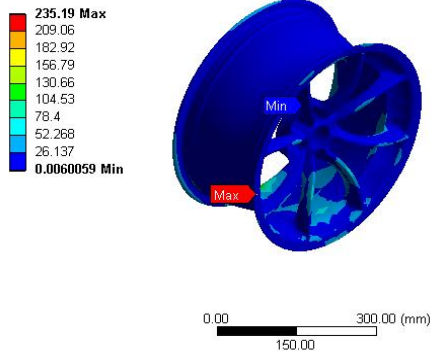

Figure 3.21: Stress Intensity of Aluminium Alloy 6061 Wheel Rim

• **Safety Factor:**

B: AA-6061 Wheel Rim Subjected to Vertical Load
 Figure
 Type: Safety Factor
 Time: 1
 7/11/2020 6:11 PM

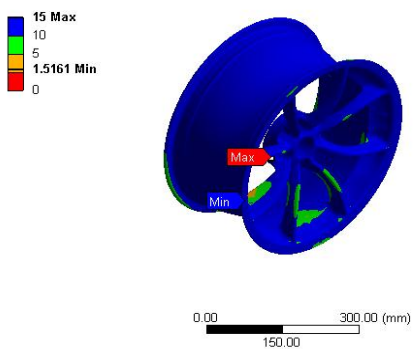

Figure 3.22: Safety Factor of Aluminium Alloy 6061 Wheel Rim

• **Stress Ratio:**

B: AA-6061 Wheel Rim Subjected to Vertical Load
 Figure
 Type: Stress Ratio
 Time: 1
 7/11/2020 6:11 PM

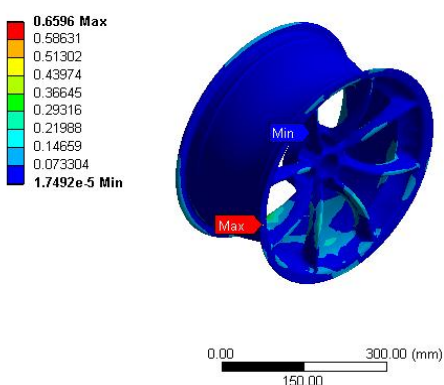

Figure 3.23: Stress Ratio of Aluminium Alloy 6061 Wheel Rim

5.1.8 Results for Static Structural Analysis of Aluminium Alloy 6061 Wheel Rim, When the Rim is Subjected to Vertical Load:

Type	Total Deformation in mm	Equivalent Stress in MPa	Stress Intensity in MPa	Safety Factor	Stress Ratio
Min	0	5.4226e-3	6.0059e-3	1.5161	1.7492e-5
Max	1.7199	204.47	235.19	15	0.6596

Table 3.4: Results for Static Structural Analysis of Aluminium Alloy 6061 Wheel Rim, When the Rim is Subjected to Vertical Load

In static structural analysis the aluminium alloy 6061 wheel rim subjected to vertical load, the vertical load of 9496N is applied vertically from downwards. The minimum total deformation is 0 at hub area and the maximum total deformation is 1.7199mm at rim portion. The minimum equivalent stress is 5.4226e-3MPa at hub and maximum equivalent stress is 204.47MPa at rim. The minimum stress intensity 6.0059e-3MPa and maximum stress intensity is 235.19MPa. The safety factor is 1.5161 and the safety margin is 0.51608. The minimum stress ratio 1.7432e-5MPa at hub and maximum stress ratio is 0.6596MPa at rim. The safety of the wheel is maximum at hub area since the maximum load acting at rim and minimum load acting at hub.

3.2 FATIGUE ANALYSIS:

Fatigue analysis must be utilized to determination of life-cycles, safety-factor, damage, fatigue sensitivity and biaxiality indication of any objects or structures. In our project-work includes the determination of fatigue life-cycles, safety, damage and fatigue sensitivity of aluminium alloy wheel rim, in addition determine the corresponding deformations and alternative stresses.

3.2.1 Fatigue Analysis of Aluminium Alloy A356.2 Wheel Rim, When the Rim Subjected to Vertical Load:

• **Life:**

B: A356.2 Alloy Wheel Rim Subjected to Vertical Load
 Figure
 Type: Life
 Time: 0
 7/12/2020 2:42 PM

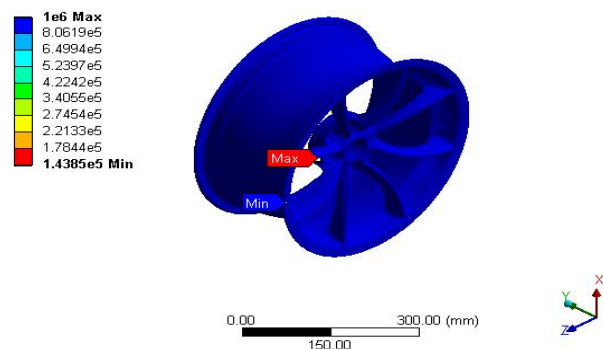

Figure 5.24: Life of Aluminium Alloy A356.2 Wheel Rim

Damage:

B: A356.2 Alloy Wheel Rim Subjected to Vertical Load
 Figure
 Type: Damage
 Time: 0
 7/12/2020 2:42 PM

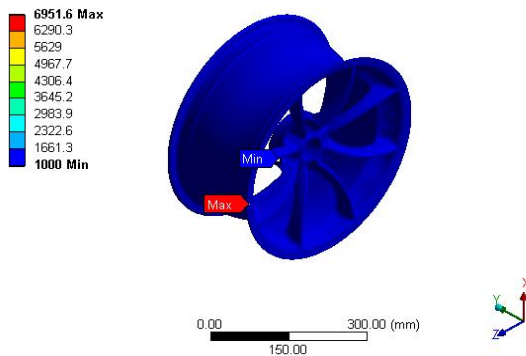

Figure 3.25: Damage of Aluminium Alloy A356.2 Wheel Rim

Equivalent Alternating Stress:

B: A356.2 Alloy Wheel Rim Subjected to Vertical Load
 Figure
 Type: Equivalent Alternating Stress
 Unit: MPa
 Time: 0
 7/12/2020 2:42 PM

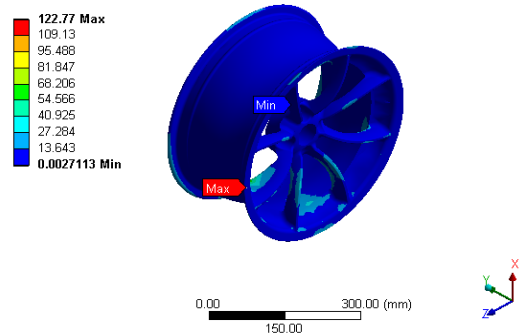

Figure 3.28: Equivalent Alternating Stress of Aluminium Alloy A356.2 Wheel Rim

Safety Factor:

B: A356.2 Alloy Wheel Rim Subjected to Vertical Load
 Figure
 Type: Safety Factor
 Time: 0
 7/12/2020 2:42 PM

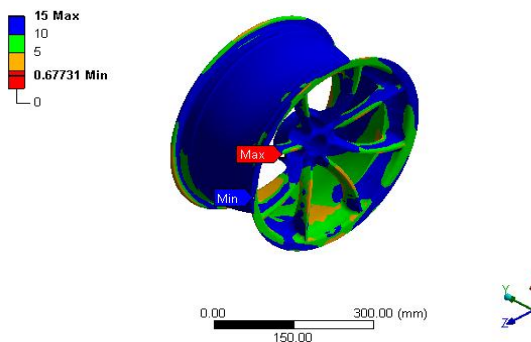

Figure 3.26: Safety Factor of Aluminium Alloy A356.2 Wheel Rim

Cycles vs Alternating Stress:

Cycles	Alternating stress MPa
10	468.01
20	419.16
50	362.32
100	325.5
200	290.63
2000	201.51
10000	156
20000	139.72
1.e+005	108.16
2.e+005	96.87
1.e+006	75

Table 3.5: Cycles vs Alternating Stress

Biaxiality Indication:

B: A356.2 Alloy Wheel Rim Subjected to Vertical Load
 Figure
 Type: Biaxiality Indication
 Time: 0
 7/12/2020 2:38 PM

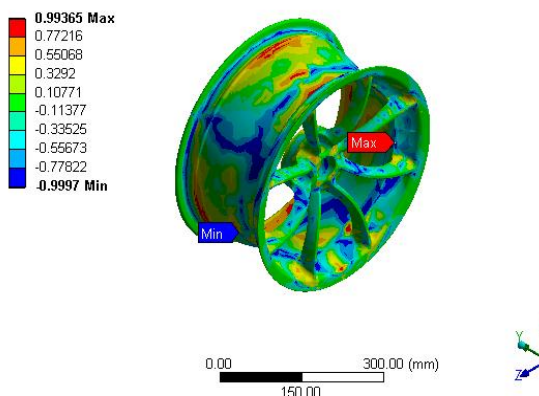

Figure 3.27: Biaxiality Indication of Aluminium Alloy A356.2 Wheel Rim

Constant Amplitude Load (Fully Reversed):

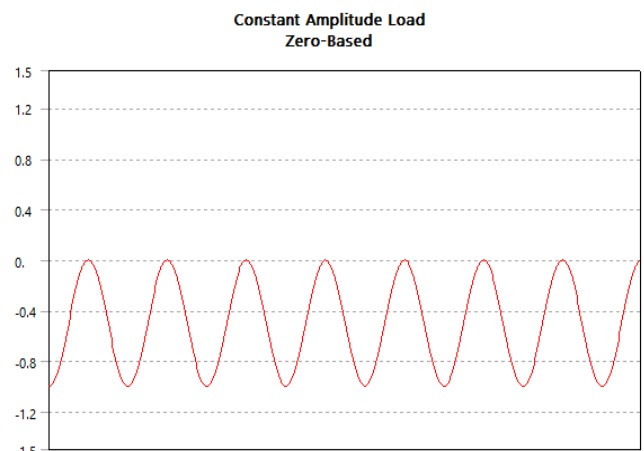

Figure 3.29: Constant Amplitude Load (Fully Reversed)

• **Graph of Fatigue Sensitivity (Available Life and Load):**

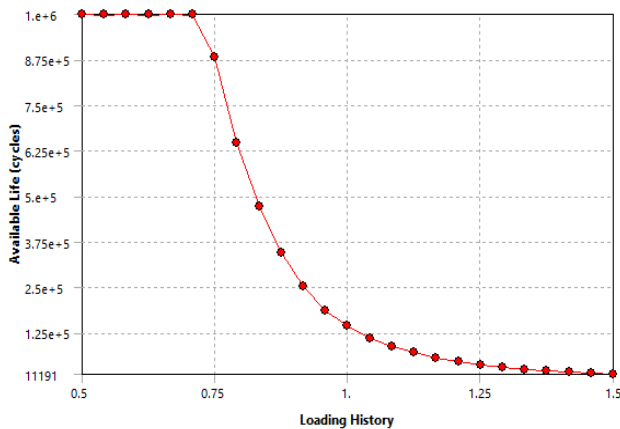

Figure 3.30: Graph of Fatigue Sensitivity (Available Life and Load).

• **Graph of Alternating Stress at Various Cycles:**

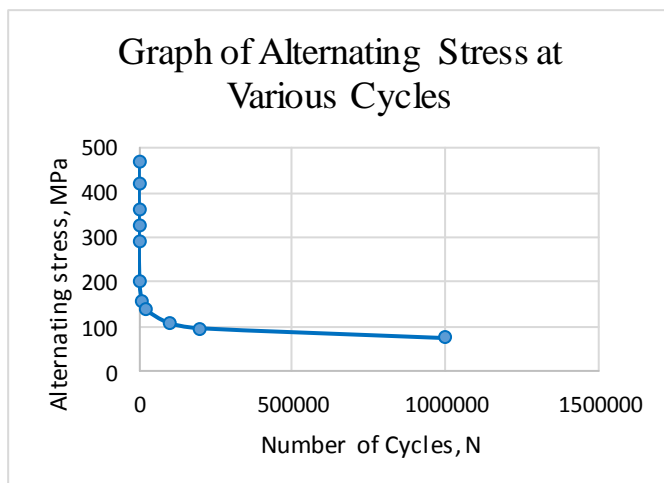

Figure 3.31: Graph of Alternating Stress at Various Cycles

3.2.2 Results for Fatigue Analysis of Aluminium Alloy A356.2 Wheel Rim, When the Rim is Subjected to Vertical Load:

Type	Life	Damage	Safety Factor	Biaxiality Indication	Equivalent Alternating Stress MPa
Min	1.4385 e5 Cycles	1000	0.67731	-0.9997	2.7113e-3
Max	1e6 Cycles	6951.6	15	0.99365	122.77

Table 3.6: Results for Fatigue Analysis of Aluminium Alloy A356.2 Wheel Rim, When the Rim is Subjected to Vertical Load

In fatigue analysis the aluminium alloy A356.2 wheel rim subjected to vertical load, the vertical load of 9496N is applied vertically from downwards. The minimum life of

wheel 1.4385e5 cycles at the cross-sectional portion of wheel and the maximum life cycles of wheel is 1e6 cycles. The damage of wheel is maximum at the cross-sectional portion of wheel spokes. The safety factor is 0.67731. The safety of the wheel is maximum at hub area since the maximum load acting at rim and minimum load acting at hub. The minimum biaxiality indication is -0.9997 and the maximum biaxiality indication is 0.99365. The minimum equivalent stress is 2.7113e-3MPa and the maximum equivalent stress is 122.77MPa.

3.2.3 Fatigue Analysis of Aluminium Alloy 6061 Wheel Rim, When the Rim Subjected to Vertical Load:

• **Life:**

B: AA-6061 Wheel Rim Subjected to Vertical Load
Figure
Type: Life
Time: 0
7/11/2020 6:11 PM

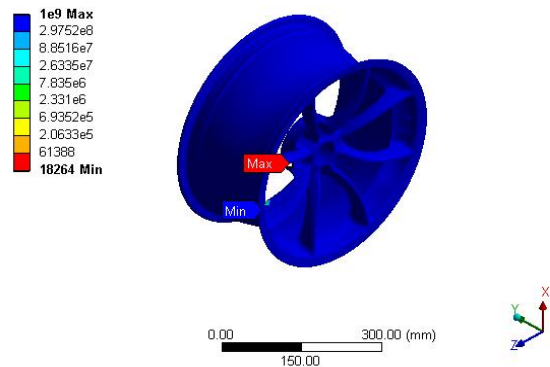

Figure 3.32: Life of Aluminium Alloy 6061 Wheel Rim

• **Damage:**

B: AA-6061 Wheel Rim Subjected to Vertical Load
Figure
Type: Damage
Time: 0
7/11/2020 6:12 PM

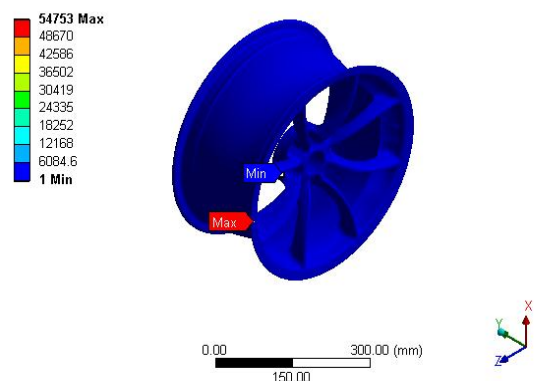

Figure 3.33: Damage of Aluminium Alloy 6061 Wheel Rim

Safety Factor:

B: AA-6061 Wheel Rim Subjected to Vertical Load
 Figure
 Type: Safety Factor
 Time: 0
 7/11/2020 6:12 PM

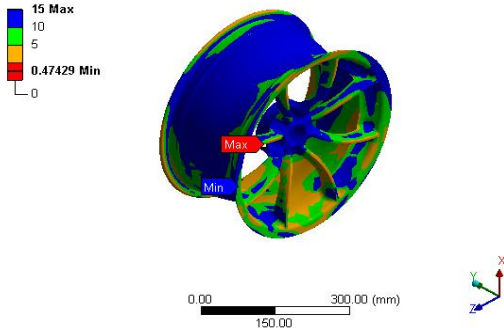

Figure 3.34: Safety Factor of Aluminium Alloy 6061 Wheel Rim

Biaxiality Indication:

B: AA-6061 Wheel Rim Subjected to Vertical Load
 Figure
 Type: Biaxiality Indication
 Time: 0
 7/11/2020 6:12 PM

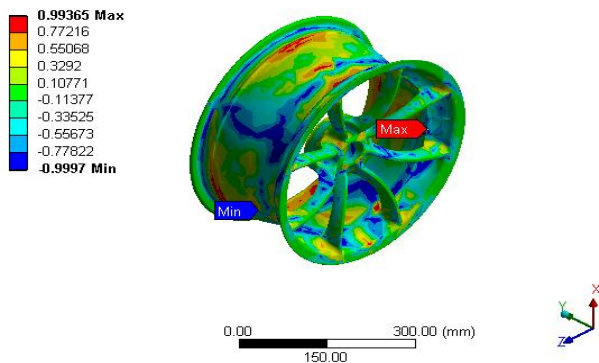

Figure 3.35: Biaxiality Indication of Aluminium Alloy 6061 Wheel Rim

Equivalent Alternating Stress:

B: AA-6061 Wheel Rim Subjected to Vertical Load
 Figure
 Type: Equivalent Alternating Stress
 Unit: MPa
 Time: 0
 7/11/2020 6:12 PM

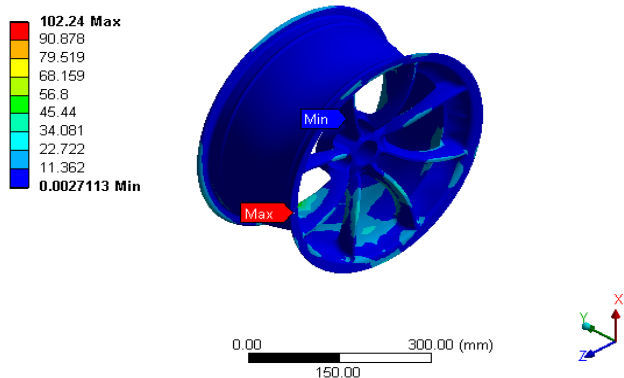

Figure 3.36: Equivalent Alternating Stress of Aluminium Alloy 6061 Wheel Rim

Cycles vs Alternating Stress:

Cycles	Alternating stress MPa
10	482.63
20	482.63
50	482.63
100	420.28
200	325.53
1000	198.91
10000	120.66
20000	99.46
1.e+005	71.15
2.e+005	64.45
5.e+005	58.5
1.e+006	55.5
2.e+006	53.38
5.e+006	51.5
1.e+007	50.55
2.e+007	49.88
5.e+007	49.28
1.e+008	48.99
2.e+008	48.77
5.e+008	48.59
1.e+009	48.49

Table 3.7: Cycles vs Alternating Stress

Constant Amplitude Load (Fully Reversed):

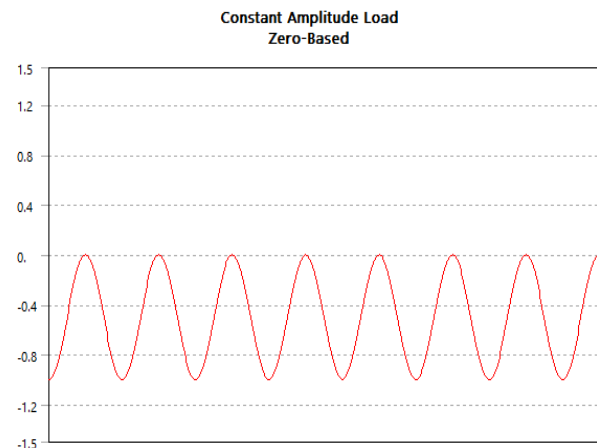

Figure 3.37: Constant Amplitude Load (Fully Reversed)

• **Graph of Fatigue Sensitivity (Available Life and Load):**

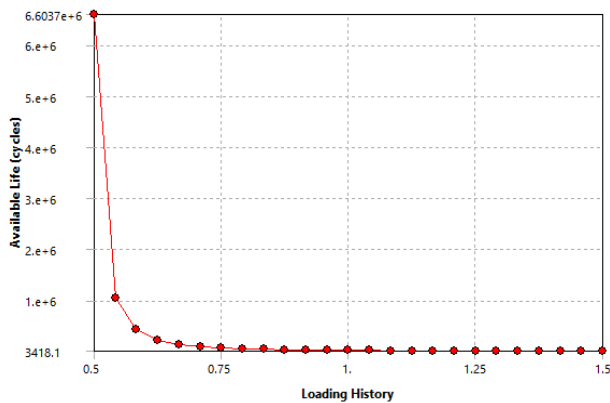

Figure 3.38: Graph of Fatigue Sensitivity

• **Graph of Alternating Stress at Various Cycles:**

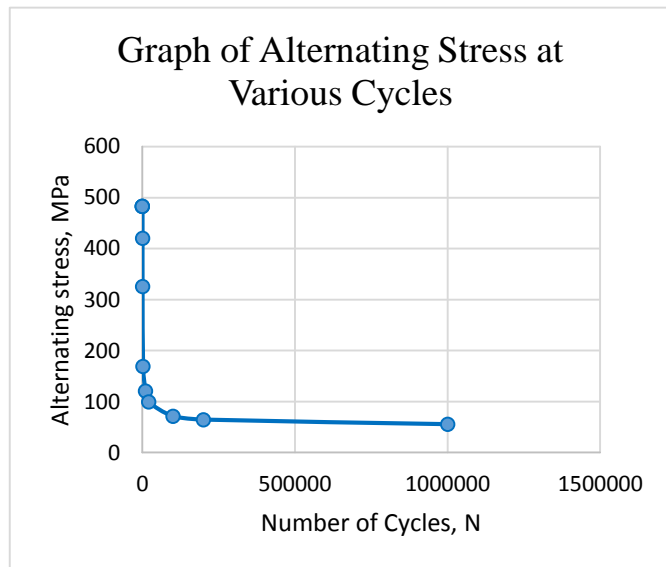

Figure 3.39: Graph of Alternating Stress at Various Cycles

3.2.4 Results for Fatigue Analysis of Aluminium Alloy 6061 Wheel Rim, When the Rim is Subjected to Vertical Load:

Type	Life	Damage	Safety Factor	Biaxiality Indication	Equivalent Alternating Stress MPa
Min	18264 Cycles	1	0.47429	-0.9997	2.7113e-3
Max	1e9 Cycles	54753	15	0.99365	102.24

Table 3.8: Results for Fatigue Analysis of Aluminium Alloy 6061 Wheel Rim, When the Rim is Subjected to Vertical Load

In fatigue analysis the aluminium alloy 6061 wheel rim subjected to vertical load, the vertical load of 9496N is applied vertically from downwards. The minimum life of wheel 18264 cycles at the cross-sectional portion of wheel and the maximum life cycles of wheel is 1e9 cycles. The damage of wheel is maximum at the cross-sectional portion of wheel spokes. The safety factor is 0.47429. The safety of the wheel is maximum at hub area since the maximum load acting at rim and minimum load acting at hub. The minimum biaxiality indication is -0.9997 and the maximum biaxiality indication is 0.99365. The minimum equivalent stress is 2.7113e-3MPa and the maximum equivalent stress is 102.24MPa.

3.3 COMPARISON OF RESULTS:

3.3.1 Comparison Results for Static Structural Analysis of Aluminium Alloy Wheel Rim, When the Rim is Subjected to Inflation Pressure:

Type	Total Deformation mm		Equivalent Stress MPa		Stress Ratio	
	Min	Max	Min	Max	Min	Max
Aluminium Alloy A356.2	0	0.1377	2.7152e-3	24.661	1.857e-5	0.10769
Aluminium Alloy 6061	0	0.1263	2.6381e-3	23.935	9.841e-6	0.08934

Table 3.9: Comparison Results for Static Structural Analysis of Aluminium Alloy Wheel Rim, When the Rim is Subjected to Inflation Pressure

By Comparing both the materials, the maximum total deformation is 0.1377mm obtained at aluminium alloy A356.2. The maximum equivalent(von-misses) stress is 24.661MPa and the maximum stress intensity is 25.418MPa, it is also obtained at aluminium alloy A356.2. The aluminium alloy 6061 gives a better results compare to aluminium alloy A356.2 because the aluminium alloy A356.2 subjected to more deformation and equivalent stress. But for both the material, the total deformation is maximum at rim flange and minimum at hub area and the equivalent(von-misses) stress is maximum at hub area and minimum at rim flange then the safety of the wheel is maximum at hub area since the maximum load acting at rim and minimum load acting at hub.

3.3.2 Comparison Results for Static Structural Analysis of Aluminium Alloy Wheel Rim, When the Rim is Subjected to Vertical Load:

Type	Total Deformation mm		Safety Factor		Stress Ratio	
	Min	Max	Min	Max	Min	Max
Aluminium Alloy A356.2	0	1.7174	1.3645	15	1.9436e-5	0.73289
Aluminium Alloy 6061	0	1.7189	1.5161	15	1.7492e-5	0.6596

Table 3.10: Comparison Results for Static Structural Analysis of Aluminium Alloy Wheel Rim, When the Rim is Subjected to Vertical Load

By Comparing both the materials, the total deformation and the equivalent stress is similar for both the materials. But the minimum stress ratio 0.6596 is obtained from aluminium alloy 6061. Consider, the aluminium alloy 6061 gives a better results compare to aluminium alloy A356.2 because the minimum stress ratio is obtained at aluminium alloy 6061. But for both the material, the total deformation is maximum at rim flange and minimum at hub area and the equivalent(von-misses) stress is maximum at hub area and minimum at rim flange then the safety of the wheel is maximum at hub area since the maximum load acting at rim and minimum load acting at hub.

3.3.3 Comparison Results for Fatigue Analysis of Aluminium Alloy Wheel Rim, When the Rim is Subjected to Vertical Load:

Type	Life		Damage		Safety Factor		Equivalent Alternating Stress MPa	
	Min	Max	Min	Max	Min	Max	Min	Max
Aluminium Alloy A356.2	1.4385e5 Cycles	1e6 Cycles	1000	6951.6	0.67731	15	2.7113e-3	122.77
Aluminium Alloy 6061	18264 Cycles	1e9 Cycles	1	54753	0.47429	15	2.7113e-3	102.24

Table 3.11: Comparison Results for Fatigue Analysis, of Aluminium Alloy Wheel Rim, When the Rim is Subjected to Vertical Load

By Comparing both the materials, the maximum life is 1e9cycles obtained at aluminium alloy A6061. And the minimum alternating stress is 102.24MPa and the minimum safety factor 0.47429, it is also obtained at aluminium alloy 6061. This alloy wheel gives a better results compare to aluminium alloy A356.2 because the aluminium alloy 6061 has more life and minimum alternating stress. But for both materials, the damage of wheel maximum at the cross-sectional area of the wheel spokes. The safety of wheel is maximum at a hub portion because the maximum load acting

at the rim and minimum load is acting at the hub. FEA(Finite-element-analysis) is completed through simulation of tests condition to examine the stress distributions and determination of fatigue life-cycle, safety, biaxiality indication and fatigue sensitivity of aluminium alloy wheel rim. The S-N curve method is used to predict the fatigue life-cycle of aluminium alloy wheel rim through simulation of structural-analysis with repeated loads are originate to converge with experiment outcomes.

4. CONCLUSIONS

Model of the wheel rim is generated in CATIA and this is imported to ANSYS for processing work. In pressure loading, the pressure 0.24821 is applied along the circumference of the wheel rims for both Aluminium Alloy A356.2 and Aluminium Alloy 6061 and hub circle of wheel rim is fixed. In vertical loading, the vertical load 9496 N applied on the wheel rim for both Aluminium Alloy A356.2 and Aluminium Alloy 6061. Following are the conclusions from the results obtained:

1. Aluminium alloy A356.2 wheel rim subjected to more deformation when compare to the aluminium alloy 6061.
2. In both cases stress generated is less than the yield strength, hence design is safe.
3. In both cases von-mises stress are less than ultimate strength.
4. Aluminium alloy 6061 wheel rim has more life when compare to the aluminium alloy A356.2.
5. The alternating stress is more in aluminium alloy A356.2 when compare to the aluminium alloy 6061.
6. By comparing all result we are suggested that Aluminium alloy 6061 is better material than aluminium alloy A356.2 for designing of alloy wheel.

REFERENCES

[1] T. Siva Prasad, T. Krishnaiah, J. Md. Iliyas, "A Review on Modeling and Analysis of Car Wheel Rim using CATIA & ANSYS", International Journal of Innovative Science and Modern Engineering (IJISME), Volume 2, Issue 6, May 2014.

[2] P. Meghashyam, S. Girivardhan Naidu and N. Sayed Baba, "Design and Analysis of Wheel Rim using CATIA & ANSYS", International Journal of Application or Innovation in Engineering & Management (IJAIEEM) Volume 2, Issue 8, August 2013.

[3] Zhan-Guang Zheng, Teng Sun, Xi-Yong Xu, Shu-Qin Pan, Shuai Yuan, "Numerical simulation of steel wheel dynamic cornering fatigue test", Engineering Failure Analysis 39 (2014).

[4] G. Previati, F. Ballo, M. Gobbi, G. Mastinu "Radial impact test of aluminium wheels-Numerical simulation and experimental validation", International Journal of Impact Engineering, 126, 117-134, 2019.

[5] J. Stearns, T.S. Srivatsan, "Modeling The Mechanical Response Of An Aluminum Alloy Automotive Rim " Material science and engineering A366, 2003.

BIOGRAPHIES



Madhusudhan R
M.Tech Student
Vidyavardhaka College of
Engineering



Dr B Sadashive Gowda
Principal
Vidyavardhaka College of
Engineering