

# Study of MIMO Precoding Techniques and their Application using Joint Spatial-Division and Multiplexing

Himanish Guha<sup>1</sup>, Rahul Mishra<sup>2</sup>

<sup>1,2</sup>Dept. of Information and Telecommunication Engineering, S. R. M. Institute of Science and Technology, Chennai, India

\*\*\*

Abstract - Massive MIMO is the key technology that will lead the way for 5G communication networks. Although it will provide us with huge gain, it presents us with a lot of implementation problems like large pilot symbols and huge overhead feedback. Now these are important requirements in determining the real time CSI. The problem is that we need a large number of RF chains and also the computational complexity increases drastically. Now these can be solved by using the mm wave spectrum. But the major problem in using such systems is the increased overhead for the CSI due to the use of Frequency Division Duplex mode. The solution to this is using joint spatial division and multiplexing (JSDM) algorithm. We analyze the performance of this algorithm. We take into account a realistic propagation channel with partial overlap of the angular spectra from different users. JSDM involves the efficient grouping of users into clusters. But in any case, we assume that the channel vectors in different clusters have separate covariance subspaces which do not overlap. The grouping is done on the basis of second order channel statistics only. We also consider the application to a more general channel model where each user group is characterized by multiple scattering clusters.

Key Words: Massive MIMO, Precoding, Prebeamformer, Prebeamforming, JSDM, Multiplexing.

## 1. INTRODUCTION

MASSIVE MIMO is a promising technology to meet the future capacity demand in wireless cellular networks. Equipped with a large number of antennas, the system has a sufficient number of degrees of freedom (DoF) to exploit the spatial multiplexing gains for intra-cell users and to mitigate the inter-cell interference. However, the corresponding beamforming (precoder) designs for such multiuser MIMO (MU-MIMO) interference networks are challenging even in traditional MIMO systems with a small number of antennas. In [1], the beamformers are jointly optimized among BSs, where the uplink-downlink duality is used to obtain the global CSI in a time division duplex (TDD) system. Using alternative optimization techniques, WMMSE algorithm is proposed in [2] with the objective to maximize the weighted sum rate for multi-cell systems. Moreover, interference alignment (IA) approaches were used in [3], [4] for downlink interference cellular networks.

We consider the beamforming design for frequency-division duplex (FDD) massive MIMO systems with a large number of antennas  $N_t$ . Unlike conventional multi-cell MU-MIMO

networks, where the schemes in [1],[2] may be easily implemented, FDD massive MIMO systems induce a lot of practical issues: (i) huge pilot symbols and feedback overheads, (ii) large number of RF chains, (iii) real-time global CSI sharing, and (iv) huge computational complexity for precoders at the BSs. For instance, the required number of independent pilot symbols for transmit side CSI (CSIT) estimation at the mobile scales as  $O(N_t)$ , and so as the CSIT feedback overheads. In addition, as  $N_t$  scales up, the number of RF chains also scales up, which induces a high fabrication cost and power consumption. Although the dynamic antenna switching techniques [3] may reduce the required number of RF chains, those solutions did not fully utilize the benefits of the extra antennas. Moreover, there is signaling latency over the backhalls, and it is highly difficult to acquire global real-time CSIT for precoding. Finally, the computational complexity for the precoding algorithms scales quickly with  $N_t$ , and low complexity precoding algorithms are needed for massive MIMO systems. In this paper, we address all the above difficulties by considering a two-tier precoding with subspace alignments. This is motivated by the clustering behavior of the user terminals. The users in the same cluster may share the same scattering environment, and hence, they may have similar spatial channel correlations. Whereas, users from a different cluster may have different spatial channel correlations. Therefore, we can decompose the MIMO precoder at the BS into an outer precoder and an inner precoder. The outer precoder is used to mitigate inter-cell and inter-cluster interference based on the statistical channel spatial covariance. Since the spatial correlations are slowly varying, the outer precoder can be computed on a slower timescale. On the other hand, the inner precoder is used for spatial multiplexing of intra-cluster users on the dimension-reduced subspace spanned by the outer precoder.

As a result, the inner precoders are adaptive to the local real time CSIT at the BS and can be computed in a faster timescale. Using the proposed two-tier precoding structure, we shall illustrate in that the aforementioned technical issues associated with large  $N_t$  can be substantially alleviated. In [4], a zero-forcing based two-tier precoding has been proposed for single cell massive MIMO systems. The outer precoders are computed using a block diagonalization (BD) algorithm. However, it requires a high complexity for computing the outer precoder, and the tracking issues for the outer precoder under time-varying channels were not addressed. In fact, the computational complexity is a serious concern in massive MIMO systems as the number of antennas scales to very large. For example, in the BD

algorithm proposed in [5] and [6], we need to apply a series of matrix manipulations including SVD to a number of  $N_t \times N_t$  channel covariance matrices each time we update the outer precoder, and the associated complexity is  $O(N^3 t)$ . In addition, deriving a low complexity iterative algorithm for the BD solution in [6] and [7] is far from trivial. To address the complexity issue, we consider online tracking solutions to exploit the temporal correlation of the channel matrices. There is a body of literature for iterative subspace tracking algorithms, for example, gradient-based algorithms [8], power iteration based algorithms [9], and the algorithms based on Krylov subspace approximations. However, these algorithms have not fully exploited the channel temporal correlations to enhance the tracking. In this paper, we propose a compensated subspace tracking algorithm for the online computation of the outer precoder. The algorithm is derived by solving an optimization problem formulated on the Grassmann manifold, and its tracking capability is enhanced by introducing a compensation term that estimates and offsets the motion of the target signal subspace. Using a control theoretical approach, we also characterize the tracking performance of the online outer precoding algorithm in time-varying massive MIMO systems. We show that, under mild technical conditions, perfect tracking (with zero convergence error) of the target outer precoder using the proposed compensation algorithm is possible, despite the channel covariance matrix being time varying. In general, we demonstrate with numerical results that the proposed two-tier precoding algorithm has a good system performance with low signaling overhead and low complexity of  $O(N^2 t)$ . The rest of the paper is organized as follows. Section II introduces the massive MIMO channel model and the signal model. Section III illustrates the two-tier precoding techniques. Section IV derives the iterative algorithm for tracking the outer precoder, where the associated convergence analysis is given in Section V. Numerical results are given in Sections VI, and VII gives the concluding remarks.

## 2. TWO STAGE BEAMFORMER DESIGN

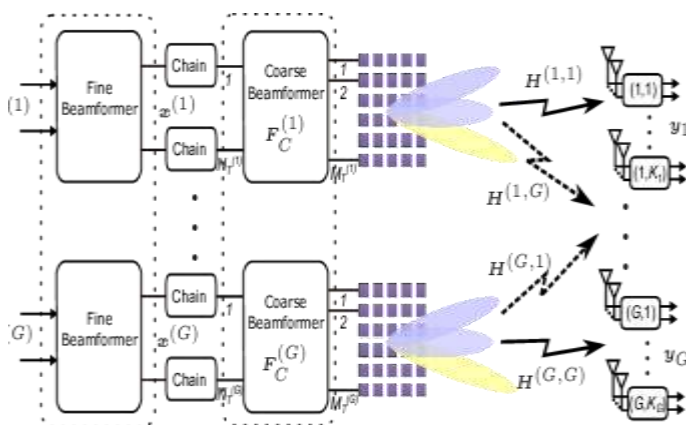

Fig -1: MIMO multi-stage beamformer

MIMO in practical systems faces several challenges especially in widely-used frequency division duplexing scenarios. In comparison to current small-scale MIMO systems, downlink channel estimation is a challenging problem for FDD massive MIMO systems since the number of available training symbols required for downlink channel estimation is obstructed by the channel coherence time and the number of channel parameters to estimate is very large [10]-[12].

Channel state information (CSI) feedback overhead for downlink user scheduling for massive FDD multi-user MIMO can be overwhelming without some smart deigning and structure on massive MIMO systems. To overcome the these difficulties associated with massive MIMO, a detailed study for two-stage beamforming concerning massive MIMO under " Joint Spatial Division and Multiplexing (JSDM) " has been carried out. The two-stage beamforming idea provides a divide-and-conquer approach. The key ideas of the two-stage beamforming strategy are

1. To partition the user population supported by the serving base station into multiple clusters each with approximately the same channel co-variance matrix i.e, virtual sectorization and
2. To disintegrate the MIMO beamformer at the base station into two steps: an outer beamformer and an inner beamformer, as shown in Fig. 1.

The outer beamformer faces the antenna array and roughly differentiates different clusters by maintaining in-group transmit power and suppressing IGI, and the inner beamformer views the product of the actual channel and the outer beamformer as an effective channel, separates the users within a group, and provides spatial multiplexing among in-group users [7]. Here, the outer beamformer is designed based on channel statistic information, not on the basis of CSI. This results in major decrement in complexity.. Several researchers followed the aforementioned framework for two-stage beamforming for massive MIMO. For implementing the inner and outer beamformer design based on CSI, linear beamforming such as Zero forcing was used [7], [10], [11]. In [7], Adhikary et al. discussed a simple block diagonalization algorithm to design the outer beamformer, which derives the outer beamformer design by taking the dominant eigen-vectors of the desired group channel covariance matrix and projecting them onto the null space of the dominant eigenspace of all other group channel covariance matrices. In [10], Chen and Lau considered the outer beamformer design criterion of minimizing the total intergroup interference power minus the weighted total desired group signal power. In this case, for a given weighting value between the total IGI power and the total in-group signal power, the outer beamformer is given by a combination of dominant eigen-vectors which are the weighted difference between the total undesirable group channel covariance matrix sum and the desirable group channel covariance matrix. In [11], it is considered that the

outer beamformer design from a accuracy perspective. In this work, they designed the outer beamformer by choosing a set of columns from a discrete Fourier transform (DFT) matrix to maximize the minimum average rate among all the users. We also consider the outer beamformer design based only on channel statistic information for the aforementioned two-stage beamforming framework for massive MIMO. As already shown in the previous works, computation of the signal-to-interference-plus-noise-ratio (SINR) for each receiver is difficult in this downlink scenario with interfering groups. To circumvent this difficulty, as our design criterion we adopt the average signal-to-leakage-plus-noise ratio (SLNR) criterion [12], which is shown to be Pareto-optimal in the achievable rate region in certain interference channel cases [13], [14], and propose an average SLNR-based outer beamformer design framework in single cell massive MIMO systems. The signal power to the desired receiver and the leakage power to other undesired receivers by the transmitter on which the SLNR method depends cannot be calculated by considering only the outer beamformer design. Instead, both the outer beamformer and the inner beamformer should jointly be considered to derive the two quantities. Thus, to further simplify the analysis we consider a Zero Forcing beamformer with equal power allocation for the inner beamformer. The simulation for analysis is performed for both Zero Forcing and regularized ZF (RZF) inner beamformers. The derivation of average SLNR is not direct due to the joint nature of the precoding method, even if we consider the assumption of Zero Forcing for the design of inner beamformer. Thus, exploiting the fact that ZF is used for the inner beamformer, we derive a lower bound on the average SLNR considering the lower bound to be a function of only channel statistics along with the outer beamformer, and our design criterion is to maximize this lower bound on the average SLNR under the constraint that the outer beamformer matrix has orthonormal columns. Then, we cast this constrained optimization problem as a trace quotient problem (TQP), which is often encountered in the field of pattern recognition, computer vision, and machine learning [15]. To obtain an optimal solution to the formulated TQP, we modify the algorithm in [16] to fit into the considered case and show the optimality and convergence of the modified algorithm based on existing results [15],[16]. The results obtained from the numericals upon being analyzed show that the proposed outer beamformer design approach yields significant sum rate gain over the algorithms in the existing systems.

In this section we see Joint Spatial-Division and Multiplexing (JSDM) which is a precoding technique for massive MIMO [7]. Let's consider a BS equipped with M antennas and serving K users, each user equipped with a single antenna. We drop the frequency variable f for making the equation simple and focus on a fixed OFDM subcarrier. Suppose that the K users are divides into G groups, where Kg users in group g have identically distributed but statistically independent channels, with a common covariance matrix

$$R_g = A_g A_g^H U_g^H$$

Denoting user k in group g by the index  $g_k$ , its channel vector is given by  $h_{gk} = U_g A_g^{1/2} w_{gk}$  where  $w_{gk} \sim \mathcal{CN}(0, I_{r_g})$  is an i.i.d. Gaussian vector (also independent across different users),  $U_g$  is a tall unitary matrix of dimensions  $M \times r_g$ ,  $A_g$  is  $r_g \times r_g$  diagonal positive definite, and  $r_g$  denotes the rank of  $R_g$ . Letting  $H_g = [h_{g1}, \dots, h_{gK_g}]$  and  $H = [H_1, \dots, H_G]$  denote the group g channel matrix and the overall system channel matrix, respectively, the received vector of signals at all the served users is given by

$$y = H^H V d + z \quad (1)$$

$y \in \mathbb{C}^K$  is the concatenated vector of signals received by the users,  $V \in \mathbb{C}^{M \times K}$  is the precoding matrix,  $d \in \mathbb{C}^K$  is the vector of transmitted data streams and  $z \in \mathbb{C}^K$  is Additive White Gaussian Noise with i.i.d. entries of mean zero and variance 1. JSDM makes use of two-stage MU-MIMO precoding, i.e., the precoding matrix is given by  $V = B P$  where the prebeamforming matrix is  $B = [B_1, \dots, B_G]$ , with blocks of dimensions  $M \times b_g$  respectively, and the MU-MIMO precoding matrix is  $P = \text{diag}\{P_1, \dots, P_G\}$  with diagonal blocks of dimensions  $b_g \times K_g$ , respectively. As anticipated before, B depends only on the second-order statistics  $\{U_g, A_g; g = 1, \dots, G\}$  of the downlink channels, whereas the MU-MIMO precoding matrices  $P_g$  are functions of the corresponding instantaneous "effective" channels  $\underline{H}_g = B_g^H + H_g$ . As a result, (6) can be re-written as

$$y = \begin{bmatrix} y_1 \\ \vdots \\ y_G \end{bmatrix} = \begin{bmatrix} H_1^H B_1 P_1 d_1 + \sum_{g' \neq 1} H_1^H B_{g'} P_{g'} d_{g'} + z_1 \\ \vdots \\ H_G^H B_G P_G d_G + \sum_{g' \neq G} H_G^H B_{g'} P_{g'} d_{g'} + z_G \end{bmatrix} \quad (2)$$

It is possible to precisely or approximately eliminate inter-group interference by appropriately selecting the correct group and the correct prebeamforming design. This can be done by implementing the following condition

$$H_g^H B_{g'} \approx 0 \text{ For all } g' \neq g \quad (3)$$

Equality can be enforced exactly if  $\text{Span}(U_g) \perp \text{Span}(\{U_{g'}; g' \neq g\})$  for all  $g = 1, \dots, G$ . This condition requires per group spatial multiplexing  $K_g$  satisfying:

$$\dim(\text{span}(U_g) \cap \text{span}^\perp(\{U_{g'}; g' \neq g\})) \geq K_g \quad (4)$$

If we find the group ranks  $r_g$  to be too big and implementing the accurate value of Block Diagonalization matrix would result in providing less number of spatial data streams  $K_g$ , we can successfully design the prebeamformer matrix according to a BD approach based on approximation. We

have to select  $r_g^*$ , the dominant eigenmodes  $U_g^*$  for each group such that  $\text{span}(U_g^*)$  isn't a subset of  $(\{U_{g'}^*: g' \neq g\})$  for all  $g = 1, \dots, G$ . The spatial multiplexing  $K_g$ , which is the group constraint can be written as

$$\dim(\text{span}(U_g^*) \cap \text{span}^\perp(\{U_{g'}^*: g' \neq g\})) \geq K_g \quad (5)$$

### 2.1 Application to the One-Cluster model

Consider again the channel model in (2) and assume that all paths correspond approximately to the same delay (i.e.,  $\tau_{kp} = \tau_k \delta_{kp}$ ) and that the  $N_k$  paths are divided into  $N_k'$  groups of  $N_k > 1$  paths each, such that the paths in the  $i$ -th cluster have approximately the same angle of arrival  $\theta_{ki} = \alpha ki$ . Hence, we can write

$$h_{mk} = \sum_{i=1}^{N_k'} \left( \sum_{p=(i-1)N}^{iN-1} \rho_{kp} e^{j\phi_{kp}} \right) e^{-j2\pi D m \sin \alpha_{ki}} \quad (6)$$

Since  $N$  is large, by the Central Limit Theorem we can assume that  $\sum_{p=(i-1)N}^{iN-1} \rho_{kp} e^{j\phi_{kp}}$  is complex Gaussian circularly symmetric. It follows that  $h_k$  is a zero-mean complex Gaussian vector with given covariance matrix  $R_k$ . Going to a diffuse scattering limit, where we assume  $N_k' \rightarrow \infty$  with uniform scattering energy  $\mathcal{O}(1/N_k')$  and angles  $\alpha ki$  spanning the interval  $[\theta_k - \Delta_k, \theta_k + \Delta_k]$ , we arrive at the one-cluster scattering model [19] with  $(m, n)$  channel covariance elements

$$[R_k]_{m,n} = \frac{1}{2\Delta_k} \int_{\theta_k - \Delta_k}^{\theta_k + \Delta_k} e^{-j2\pi D(m-n)\sin \alpha} d\alpha \quad (7)$$

We briefly outline the approximate BD approach to design the pre-beamforming matrix. Suppose that the users are partitioned into  $G$  co-located groups, each of which is identified by its own one-cluster scattering channel, i.e., all users  $gk$  in group  $g$  have the same  $\theta_g$  and  $\Delta_g$ . Defining

$$\Xi_g = [U_{g1}^*, \dots, U_{g-1}^*, U_{g+1}^*, \dots, U_{gG}^*] \quad (8)$$

of dimensions  $M \times \sum_{g' \neq g} r_{g'}^*$  and rank  $\sum_{g' \neq g} r_{g'}^*$ , and letting  $[E_g^{(1)}, E_g^{(0)}]$  denote a system of left eigenvectors of  $\Xi_g$ , we have that  $\text{span} E_g^{(0)} = \text{span}^\perp(\{U_{g'}^*: g' \neq g\})$ .

The pre-beamforming matrix  $B_g$  is obtained by concatenating the projection onto  $\text{span} E_g^{(0)}$  along with eigenbeamforming along the dominant eigenmodes of the covariance matrix of the projected channels of group  $g$ . Denoting the covariance matrix of  $h_{gk} = (E_g^{(0)})^H h_{gk}$  as

$$\hat{R}_g = (E_g^{(0)})^H U_g \Lambda_g U_g^H (E_g^{(0)}) = G_g \Phi_g G_g^H \quad (9)$$

Where  $G_g$  and  $\Phi_g$  denote the matrix of eigenvectors and eigenvalues of  $\hat{R}_g$ , we obtain

$$B_g = (E_g^{(0)}) G_g^{(1)} \quad (10)$$

Where  $G_g^{(1)}$  contains the dominant  $K_g$  eigenmodes of  $\hat{R}_g$ . When  $K_g \geq K_g > 1$ , in order to harness the spatial multiplexing in each group, we consider the effective channel matrix of group  $g$  given by  $H_g = B_g^H H_g$  and use for each group  $g$  the classical zero-forcing MU-MIMO precoding given as

$$P_g = \zeta_g^2 H_g (H_g^H H_g)^{-1} \quad (11)$$

Where  $\zeta_g^2$  is a power normalization factor. Note that the number of data streams  $K_g$  that can be spatially multiplexed in group  $g$  cannot be larger than the rank of the equivalent channel, given by  $K_g$ .

### 2.2 Multiple Scattering Clusters

JSDM was originally proposed for a system where users can be partitioned in groups with (approximately) same covariance subspaces. Efficient user grouping algorithms for JSDM are proposed in [17]. In any case, the underlying assumption is that the channel vectors in different groups have dominant covariance subspaces that almost do not overlap, such that BD or approximate BD can efficiently separate the groups on the basis of the channel second-order statistics only. In this section, we go one step beyond the one-cluster model and consider the application of JSDM to a more general channel model where each user group is characterized by multiple scattering clusters, and where these clusters may significantly overlap (common scatterers). We formalize the problem and present algorithms for selecting users and allocating spatial dimensions. Fig. (2) Shows the case of two user groups, each of which has its own cluster of local scatterers, which share a common remote scattering cluster. Generalizing this idea, we consider a model where each user  $k$  is characterized by multiple disjoint clusters of scatterers, spanning angle of arrivals in a union of intervals. For simplicity, we still assume a uniform power distribution over the planar waves impinging on the BS antenna.

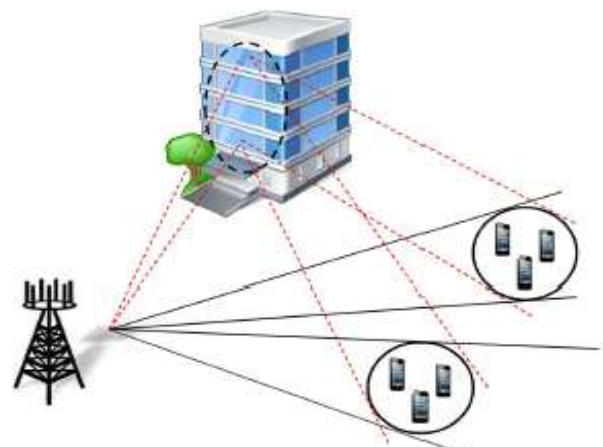

$$[R_k]_{m,n} = \frac{1}{N_k^{cl}} \sum_{c=1}^{N_k^{cl}} \frac{1}{2\Delta_{kc}} \int_{\theta_{kc}-\Delta_{kc}}^{\theta_{kc}+\Delta_{kc}} e^{-j2\pi D(m-n)\sin \alpha} d\alpha \quad (12)$$

Where  $N_k^{cl}$  is the number of scattering clusters associated to user  $k$ , and  $\theta_{kc}$  and  $\Delta_{kc}$  denote the respective azimuth angle and angular spread of cluster  $c$  of user  $k$ . One can incorporate different power levels to the scattering clusters by using a weighted sum of the terms in (12). In order to motivate the general problem of selecting users with multiple scattering clusters and gain insight on the design of suitable algorithms for this purpose, we first consider the example of Fig. 2, which shows the effect of a single common scattering cluster. Because of the presence of the common scatterers, in order to simultaneously serve users in different groups we need to project the transmit signal in the orthogonal subspace of the eigendirections corresponding to the common scatterer. Hence the pre-beamforming projection is able to decouple the groups in such a way that each MU-MIMO group is able to achieve some group spatial multiplexing

However, in doing so we preclude the possibility of using the paths going through the common scatterer to convey signal energy to the MSs. Hence, an alternative approach consists of serving the two groups on different time-frequency slots (Orthogonal transmission resources), but maximize the signal energy transfer to each of the groups by exploiting all the available MPC combining. Summarizing, we have two possible approaches:

1. Multiplexing: we employ BD to orthogonalize the groups in the spatial domain via the pre-beamforming matrix. Hence inter-group interference is eliminated and we are able to serve two groups at once with the same transmission resource.
2. Orthogonalization: we serve the user groups in different channel transmission resources, and use the prebeamforming matrix to transmit over all the channel eigenmodes (including the common scatters) to each group separately.

### 3. GENERALISED DESIGN OF MULTI USER MIMO PRECODING MATRICES

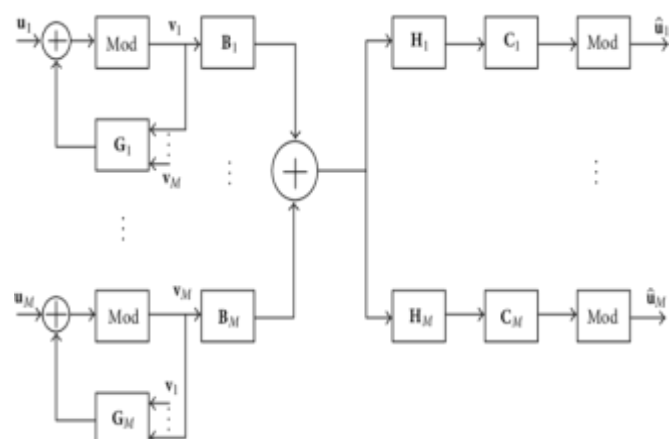

An important research topic is the study of multi-user (MU) MIMO systems. Such systems have the potential to combine the high throughput achievable with MIMO processing with the benefits of space division multiple access (SDMA). This allows the transmission of multiple spatially multiplexed (SMUX) data streams to multiple users which results in very high data rates. In this case, the base station has the ability to coordinate the transmission from all of its antennas. The challenge is that the receiving antennas that are associated with different users are typically unable to coordinate with each other. By mitigating or ideally completely eliminating multi-user interference (MUI), the BS exploits the channel state information (CSI) available at the transmitter to allow these users to share the same channel. It is essential to have CSI at the base station since it allows joint processing of all users' signals which results in a significant performance improvement and increased data rates. The information theoretic results in [3], [6], [7], [8], [9] have shown that it is necessary to use some kind of Costa's "dirty-paper" coding (DPC) or Tomlinson-Harashima precoding to reach the sum capacity of a multi-user MIMO downlink system. DPC can achieve the maximum sum rate of the system and can provide the maximum diversity order. However, these techniques require the use of a complex sphere-decoder or an approximate closest-point solution, which makes them hard to implement in practice. THP is strongly related to DPC, and it represents a suboptimal implementation of DPC.

Generalized designs of a jointly optimum linear precoder and decoder for a single user (SU) MIMO system, using a mean-squared error (MSE) criterion are given in [10] and [11]. The framework presented in these papers is general and addresses several optimization criteria like minimum MSE (MMSE), minimum bit error rate (BER), and maximum information rate. However, these results are limited only to point-to-point communication where the transmitter and the receiver are able to perform a joint processing over all of the transmit and the receive antennas. There are a lot of results in the literature which address the optimization of multi-user MIMO downlink systems using different optimization criteria. However, there is no general solution like in the case of point to-point communications. For the optimization of such systems it is often assumed that the users are equipped with only one antenna, [12], [13], [14]. Solutions that consider an arbitrary number of antennas at the user terminals (UT) often assume zero multi-user interference which imposes a constraint regarding the total number of antennas at the BS and the UTs, [18]. The solutions that overcome this dimensionality constraint, i.e., when the number of receive antennas is greater than the number of antennas at the base station either use only a subset of antennas or a subset of eigenmodes [18], [19], and usually require a large control overhead in order to feedback the decoding matrices to the user terminals. One approach that is addressing the problem of the system dimensionality was proposed in [20] and it is called successive MMSE precoding (SMMSE). SMMSE provides higher antenna and diversity gain than MMSE by suppressing the interference only between the antennas located at the two different terminals.

SMMSE in combination with THP [21] reaches the sum-rate capacity of the broadcast channel at low SNRs.

In this paper we use a different approach. We separate the problem of MUI mitigation and the optimization of the overall system performance with respect to the different optimization criteria. Our goal is to use as much as possible of the available users' spatial resources and at the same time minimize the interference between different users. In combination with THP or by iterating the closed form solution we reach the maximum sum rate capacity of the broadcast channel in simulations. By iterating or by joint precoding in two other dimensions, time and frequency, were able to extract the maximum diversity in the system.

#### 4. MULTI-USER LINEAR PRECODING FOR MULTI-POLARIZED MASSIVE MIMO SYSTEM

Another challenge of the Massive MIMO system is the antenna space limitation. An increasing number of antenna elements is difficult to be packed in a limited space and if it can be deployed, the high spatial correlation and the mutual coupling among the antennas elements may cause some system performance degradation, especially for a small numbers of active MSs [22], [23]. The multi-polarized antenna elements can be one solution to alleviate the space constraint [24]. The multi-polarized antenna systems have been investigated under various communication scenarios including the picocell/microcell [16], indoor/outdoor [17], and the line of sight (LOS)/non LOS (NLOS) [15] environments. Despite the realization of polarized antennas in realistic deployments, the Massive MIMO system along with multi-polarized antenna elements has not been remitted together with the multi-user linear precoding. Note that due to space constraints, closely spaced dual-polarized antennas is considered as the first priority deployment scenario for MIMO in LTE-A and is therefore likely to remain so as the number of antennas at the base station increases [10], [11], [18].

In this paper, we first model the Massive multi-user MIMO system, where the BS is equipped with a large number of multi-polarized antenna elements. For simplicity and practical issue of MS, we consider that MSs are equipped with a single single-polarized antenna element. It is then presented that the dual-structured precoding is based on either long-term or short-term CSIT. As done in the Massive MIMO system with a single-polarized antenna element [8], by grouping the spatially correlated MSs and multiplying the channel matrix of the grouped MSs with the same preprocessing matrix proportional to spatial correlation, the dimension gathered from the precoding signal space along with the corresponding short-term CSIT dimension can be diminished using the Karhunen-Loeve transform. Considering the multi-polarized Massive multi-user MIMO system for the first time, the contributions of this paper are listed below:

1. To further improve the efficiency and performance in the feedback overhead, a linear precoding which is dual structured, and also the subgrouping method additionally applied to the spatially grouped MSs in the pre-processing stage is based on polarization. By subgrouping the co-polarized Mobile Stations onto different groups, the Mobile Station reports the CSI from the elements of the transmit antenna having the same polarization, as it's own polarization. The short term CSI feedback overhead, can be further reduced by MS, compared to the spatial correlation based conventional preprocessing.
2. Under the imperfect CSIT, two different dual structured precodings with preprocessing of
  - i. grouping based only on the spatial correlation (i.e., spatial grouping)
  - ii. subgrouping based on both the spatial correlation and polarization

These are asymptotically analyzed based on random matrix theory with a large dimension [7]. Because, in this paper, the polarized Massive MU-MIMO channel is considered, the asymptotic inter/intra interferences are evaluated over the polarization domain as well as the spatial domain, which addresses a more general (polarized) channel environment compared to [7], [8]. Accordingly, the asymptotic performance can be further analyzed in terms of both the polarization and the spatial correlation and therefore, we can understand the performance behavior of dual structured precoding with respect to the long-term CSIT.

3. Since, it involves dual structured precoding strategies, a new dual precoding to switch between the modes in precoding is proposed. These precoding strategies rely on
  - i. the spatial grouping only and
  - ii. the subgrouping based on both the spatial correlation and polarization.
4. Motivated by 3D beamforming [8], [20], we extend the design to the 3D dual structured precoding in which the spatial correlation depends on both azimuth and elevation angles.
5. We also investigate and discuss how the proposed precoding mode switching scheme can be modified when the Base Station and the Mobile Station have mismatched polarization.

Note that, from the asymptotic results, we can find that even though the proposed dual precoding using the subgrouping can reduce the feedback overhead, its performance can be affected by the cross-polar discrimination (XPD) parameter.

Here, XPD refers to channel depolarization along with long-term statistics of the antenna elements. Channel depolarization measures the ability to differentiate the orthogonal polarization. That is, under the same feedback overhead, the dual precoding with subgrouping can utilize more accurate CSIT on half of the array, compared with precoding with spatial grouping, but exhibits performance more sensitive to the XPD. If the precoding with spatial grouping is considered, its performance is not affected by the XPD, but can only utilize less accurate CSIT. Accordingly, we identify the region where the dual precoding with subgrouping outperforms that with spatial grouping. The region is directly proportional on the XPD, the spatial correlation, and the short-term CSIT quality. The proportionality to these three variables inclined us to promote the new dual precoding method.

Considering the results we obtained from the asymptotic analysis we propose a new dual structured precoding/feedback structure and also several views along with supporting simulation results.

### 3. CONCLUSION

In this paper, an algorithm involving lower complexity for tracking the outer precoder under the two-tier precoding in massive MIMO systems and time-varying channels is observed. The two-tier precoding scheme tries to combat various implementation hurdles which come up in massive MIMO systems, namely, the huge pilot symbols and feedback overhead, realtime global CSI requirement, large number of RF chains, and high computational complexity. To reduce the complexity in computation for the outer precoder, an iterative algorithm is proposed based on optimization problem formulated on the Grassmann manifold, and its tracking performance is further enhanced by projecting a compensation technique to offset the time variation of the desirable solution. In this work we have considered the application of the JSDM approach to highly directional channels formed by a few discrete MPCs, typically arising in outdoor mm-Wave communications. In general, JSDM with good user selection turns out to be an effective method for the implementation of multiuser MIMO downlink in massive MIMO systems. The scheme can take advantage of highly directional channel statistics, as those arising in mm-Wave frequencies. In particular, in a typical small-cell scenario where the number of users is significantly less than the number of base station antennas, and the user channels are formed by a small number of discrete multi-path components, we have proposed a simple "covariance-based" JSDM scheme that achieves remarkable spatial multiplexing while the pre-requisite being only the knowledge of the channel's second order statistics. This scheme is particularly attractive since it does not require instantaneous CSIT

feedback, and the channel covariances can be accurately learnt and tracked since they depend on the scattering in the environment, and are changing very slowly for nomadic users, typically in small cell networks.

### REFERENCES

- [1] H. Dahrouj and W. Yu, "Coordinated beamforming for the multicell multi-antenna wireless system," *IEEE Trans. Wireless Commun.*, vol. 9, no. 5, pp. 1748–1759, May 2010
- [2] Q. Shi, M. Razaviyayn, Z.-Q. Luo, and C. He, "An iteratively weighted MMSE approach to distributed sum-utility maximization for a MIMO interfering broadcast channel," *IEEE Trans. Signal Process.*, vol. 59, no. 9, pp. 4331–4340, Sep. 2011.
- [3] B. Zhuang, R. A. Berry, and M. L. Honig, "Interference alignment in MIMO cellular networks," in *Proc. IEEE ICASSP*, 2011, pp. 3356–3359.
- [4] M. Guillaud and D. Gesbert, "Interference alignment in partially connected interfering multiple-access and broadcast channels," in *Proc. IEEE GLOBECOM*, 2011, pp. 1–5.
- [5] S. Sanayei and A. Nosratinia, "Antenna selection in MIMO systems," *IEEE Commun. Mag.*, vol. 42, no. 10, pp. 68–73, Oct. 2004.
- [6] I. Berenguer, X. Wang, and V. Krishnamurthy, "Adaptive MIMO antenna selection via discrete stochastic optimization," *IEEE Trans. Signal Process.* vol. 53, no. 11, pp. 4315–4329, Nov. 2005.
- [7] A. Adhikary, J. Nam, J. Ahn, and G. Caire, "Joint spatial division and multiplexing—the large-scale array regime," *IEEE Trans. Inf. Theory*, vol. 59, no. 10, pp. 6441–6463, Oct. 2013.
- [8] A. Adhikary and G. Caire, "Joint Spatial Division and Multiplexing: Opportunistic Beamforming and User Grouping 2013," *arXiv preprint arXiv: 1305.7252*
- [9] P. Comon and G. H. Golub, "Tracking a few extreme singular values and vectors in signal processing," *Proc. IEEE*, vol. 78, no. 8, pp. 1327–1343, Aug. 1990.
- [10] S. Noh, M. D. Zoltowski, Y. Sung, and D. J. Love, "Pilot beam pattern design for channel estimation in massive MIMO systems," *IEEE J. Sel. Topics Signal Process.* vol. 8, no. 5, pp. 787–801, Oct. 2014.
- [11] J. So, D. Kim, Y. Lee, and Y. Sung, "Pilot signal design for massive MIMO systems: A received signal-to-noise-ratio-based approach," *IEEE Signal Process. Lett.*, vol. 22, no. 5, pp. 549–553, May 2015.

[12] S. Noh, M. Zoltowski, and D. Love, "Training sequence design for feedback assisted hybrid beamforming in massive MIMO systems," *IEEE Trans. Commun.*, submitted for publication, 2015. [Online].

Available: <http://arxiv.org/pdf/1407.1786v1.pdf>

[13] R. Zakhour and D. Gesbert, "Coordination on the MISO interference channel using the virtual SINR framework," in *Proc. Int. ITG Workshop Smart Antennas*, Berlin, Germany, Feb. 2009, pp.1-7.

[14] J. Park, G. Lee, Y. Sung, and M. Yukawa, "Coordinated beamforming with relaxed zero forcing:

The sequential orthogonal projection combining method and rate control," *IEEE Trans. Signal Process.*, vol. 61, no. 12, pp. 3100-3112, Jun. 2013.

[15] H. Shen, K. Diepold, and K. Hüper, "A geometric revisit to the trace quotient problem," in *Proc. Int. Symp. MTNS*, 2010, pp. 1-4.

[16] L. Zhang, W. Yang, and L. Liao, "A note on the trace quotient problem," *Optim. Lett.*, vol. 8, no. 5, pp. 1637-1645, Jun. 2014.

[17] J. Nam, A. Adhikary, J.-Y. Ahn, and G. Caire, "Joint spatial division and multiplexing: Opportunistic beamforming, user grouping and simplified downlink scheduling," *IEEE J. Sel. Topics Signal Process.*, Mar. 2014.

[18] V. Stankovic and M. Haardt, "Successive optimization Tomlinson-Harashima precoding (SOTHP) for multi-user MIMO systems," in *Proc. IEEE Int. Conf. Acoust., Speech, and Signal Processing (ICASSP)*, Philadelphia, PA, USA, March 2005.

[19] P. Tejera, W. Utschick, G. Bauch, and J. Nosssek, "A novel decomposition technique for multi user MIMO," in *Proc. 6<sup>th</sup> International ITG Conference on Source and Channel Coding (ITGSCC'05)*, Apr. 2005.

[20] V. Stankovic and M. Haardt, "Multi-user MIMO downlink precoding for users with multiple antennas," in *Proc. 12-th Meeting of the Wireless World Research Forum (WWRF)*, Toronto, ON, Canada, Nov. 2004.

[21] "Novel linear and non-linear multi-user MIMO downlink precoding with improved diversity and capacity," in *Proc. 16-th Meeting of the Wireless World Research Forum (WWRF)*, Shanghai, China, Apr. 2006

[22] B. Clerckx, G. Kim, and S. Kim, "Correlated fading in broadcast MIMO channels: curse or blessing?" in *Proc. IEEE Global Telecommunications Conference*, 2008, Nov. 2008.

[23] B. Clerckx, C. Craeye, D. Vanhoenacker-Janvier, and C. Oestges "Impact of antenna coupling on 2x2 MIMO communications," *IEEE Trans. Veh. Technol.*, vol. 56, no. 3, pp. 1009-1018, May 2007.

[24] T. Kim, B. Clerckx, D. J. Love, and S. J. Kim, "Limited feedback beamforming systems for dual-polarized MIMO channels," *IEEE Trans. Wireless Commun.*, vol. 9, no. 11, pp. 3425-3439, Nov. 2010.

[25] C. Oestges, B. Clerckx, M. Guillaud, and M. Debbah, "Dual-Polarized wireless communications: from propagation models to system performance evaluation," *IEEE Trans. Wireless Commun.*, vol. 7, no. 10, pp. 4019-4031, Oct. 2008.