

Electricity Generation from Waste Heat and Safety from Gas Leakage

Vikas Devkate¹, Mangesh Gite², Abhijit Dandale³, Prof. Amol Varade⁴

^{1,2,3}student, Dept. of Electrical Engineering, AVCOE, Sangamner, Maharashtra, India.

⁴Assistant Pofesser, AVCOE, Sangamner, Maharashtra, India

Abstract- In India, gas stove is use for cooking in almost every house. During this, some amount of heat generated by flames is get wasted due to open air. In this project we propose a gas stove with TEG plates. In which extra heat is use by TEG plates to generate electricity. Voltage is produce due to temperature difference between terminal of TEG plate. The produced voltage is not sufficient to store in battery. So the voltage is boosted up to required level using a DC-DC converter. The boosted up voltage is saved in battery that is used as a backup. Due to regular use of gas stove, there is always a risk of gas leakage. Here we are also adding an IOT based gas leak detection and alert system in this project. This feature will run on energy generated by TEG plates. So no external energy is required for this feature. Gas leakage and alert will be done using LPG gas sensor, ATmega 328 microcontroller and ESP8266 Wi-Fi module.

Key Words: 1. peltier plate 2. Gas sensor(MQ2) 3. IoT

4. Gas stove

1. INTRODUCTION

In the 21st century need of energy and humilation of environment are among the major two problems. Thermoelectric devices provide a answer to such problems. Thermo electric devices are very small in size and thus finds a good range of application in areas like military, marine, space rovers, industry, food and packaging industry etc. A thermoelectric generator is a device which converts thermal energy into electrical energy due to the presence of temperature gradient . TEG has many advantages that it has no mechanical parts, environmental friendly and maintenance is easy . Thermo electric generator (TEG) module is used here, which generates electrical energy from the excess heat generated and not used during cooking on gas stove. The waste heat can be utilized and therefore reduces the use of fossil fuels and thereby pollution can be reduced to some extent .

In India, gas stove is use for cooking in almost every house. During this, some amount of heat generated by flames is get wasted due to open air. In this project we propose a gas stove with TEG plates. In which extra heat is use by TEG plates to generate electricity. Due to the temperature difference between two sides of TEG plate a voltage (current) is produced between both terminals. The produced voltage is not sufficient to store in battery. So the voltage is boosted up to required level using a DC-DC converter. The boosted up voltage is saved in battery that is used as a backup. Due to regular use of gas stove, there is always a risk

of gas leakage. Here we are also adding an IOT based gas leak detection and alert system in this project. This feature will run on energy generated by TEG plates. So no external energy is required for this feature.

2. NEED

Out of the many things, there are major reasons for development of this project. Which are:

Electricity Crises in the world:

Electricity is critical aspect for economic growth of India. The country is on the fast course of growth but to keep the momentum of growth high, availability of uninterrupted power supply is a must. India needs electricity to growth of every industry, be it large-scale or small scale, manufacturing, healthcare or education. To satisfy the need of electricity, we always need to search for energy generation systems with better performance and less environmental damage, free from pollution. Sea is the unlimited source of energy. So in this project we are developing prototype for electricity generation system using waste heat.

Safety from gas leak & fire accident

Due to regular use of gas stove, there is always a risk of gas leakage. There are many victims of domestic gas leak in India and world every year. To minimize this problem, we are adding an IOT based gas leak detection and alert system in this project. This feature will run on energy generated by TEG plates. So no extra energy is required for this safety feature. Gas leakage and alert will be done using LPG gas sensor, AT-MEGA328 microcontroller and ESP8266 Wi-Fi module.

3. DESCRIPTION OF THE PROJECT

In this design the hardware components that we use are:

- TEG Plate
- Boost Converter
- Battery
- Atmega-328 controller
- Wi-Fi Module

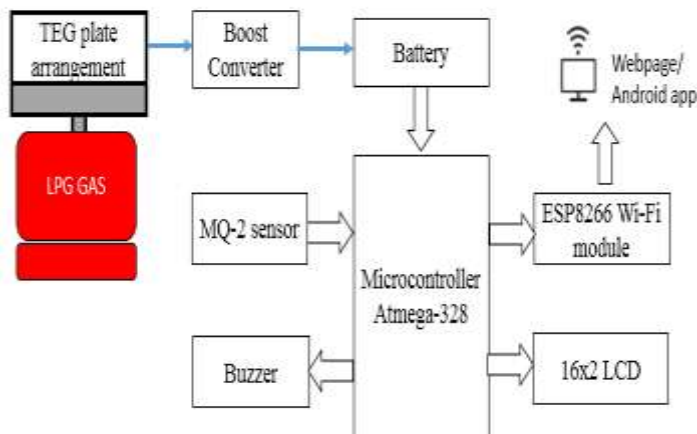

Fig -1: system block diagram

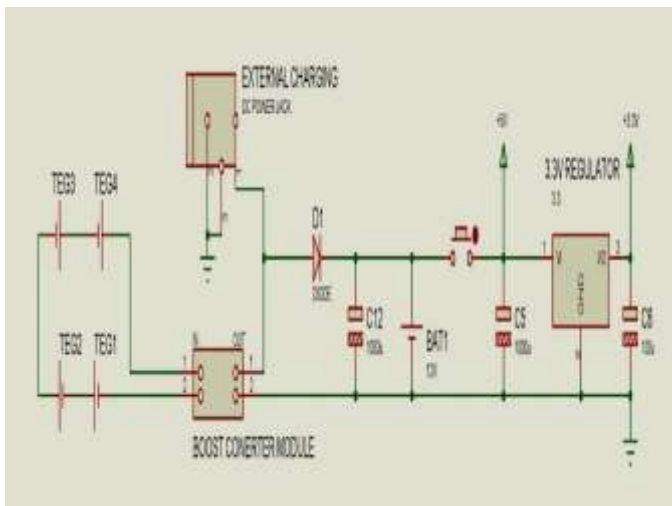

Fig -2: Circuit Diagram of System

3.1 TEG Plates



Fig -3: TEG plate

Features:

- Designed specifically for power generation.
- Contain thermal elements formulated for better power generation.
- Requires 90 degree temperature difference to generate with full efficiency.
- Sealed for moisture protection and
- High-temperature 150C, with NM static protection.

- Small and lightweight, convenient for use.
- 2nd generation booster module with step-up transformer.

3.2 Boost converter



Fig -4: Boost Converter

Features:

- Input voltage: 0.9-5V DC
- Output voltage: 5V DC
- Output Current: 500-600mA
- 96% conversion efficiency

3.3 Battery 4V, 1 Ahr Sealed lead acid

The rechargeable batteries are lead-lead dioxide systems. The dilute sulfuric acid electrolyte is absorbed by separators and plates and thus do not move. Should the battery be accidentally overcharged producing hydrogen and oxygen, special a method valves allow the gases to flee thus avoiding excessive pressure build-up.



Fig -5: Sealed Lead Acid Battery

Features:

- Absorbent Glass Mat (AGM) technology for efficient gas recombination of up to 99% and freedom from electrolyte maintenance or water adding.
- Can be mounted in any orientation.
- Computer designed lead, calcium tin alloy grid for high power density.
- Long service life, float or cyclic
- Maintenance-free operation

3.4 Microcontroller ATMEGA328:

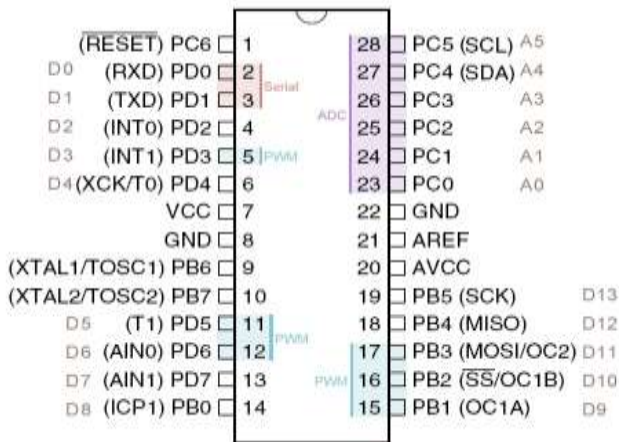

Fig- 6: Pin diagram of Atmega328 microcontroller

Features:

- 28 pin IC with 20 GPIO pins
- Inbuilt 6 channel ADC
- 2kb SRAM, 1kb EEPROM
- 32 General purpose registers
- Works on 5V
- Low power Sleep mode
- Multiple software tool support

3.5 Wi-Fi Module

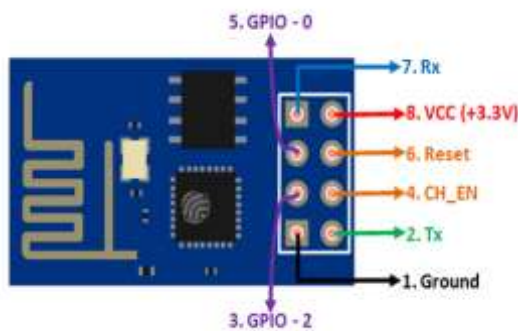

Fig- 7:Wi-Fi Module

The ESP8266 Wi-Fi Module may be a self-contained SOC with integrated TCP/IP protocol stack which will give any microcontroller access to your Wi-Fi network. The ESP8266 is capable of either hosting an application or offloading all Wi-Fi networking functions from another application processor. Each ESP8266 module comes pre-programmed with an AT command set firmware, meaning, you'll simply hook this up to your Arduino device and acquire about the

utmost amount Wi-Fi-ability as a Wi-Fi Shield offers (and that's just out of the box)! The ESP8266 module is a particularly cost effective board with an enormous, and ever growing, community. This module features a strong enough on-board processing and storage capability that allows it to be integrated with the sensors and other application specific devices through its GPIOs with minimal development up-front and minimal loading during runtime. Its high degree of on-chip integration allows for minimal external circuitry, including the front-end module, is supposed to occupy minimal PCB area.

Specifications:

- Power Supply: +3.3V
- Current Consumption: 100mA
- Built-in low power 32-bit MCU
- Supports Deep sleep

4. RESULT

Times (sec)	Voltage(V)
60	4.18
120	6.56
180	7.25
240	7.99
300	10.04
360	11.21
420	12.24
480	13.35
540	14.77
600	14.85
680	14.77

Table- 1: Data table for voltage and time

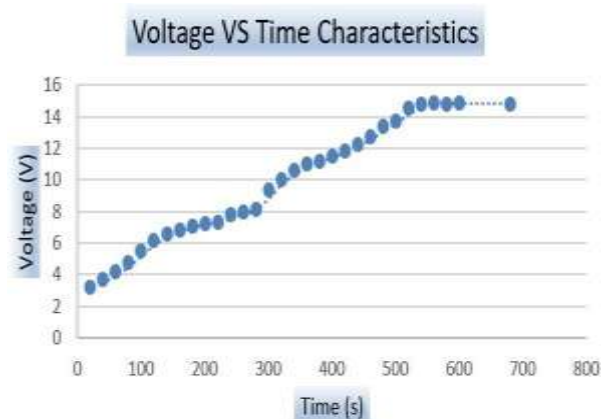

Chart- 1: Voltage vs Time Curve.

Fig. represents the voltage generation with respect to the time according to the data of table . The figure shows that voltage increases proportionally with time. after 9 minutes

the output voltage of that TEG plate goes on saturation mode. And the output voltage is around 14 to 15V.

5. CONCLUSION

Satisfying energy requirement of world is crucial task. In this project, we are trying to implement a prototype which will be helpful for energy generation in future. We studied different energy generation system and designed one on the basis of knowledge obtained from other systems.

Though design is ready, actual implementation of prototype will begin in next phase of project, in which we will measure and analyze the output power generated by TEG system. To achieve a target temperature difference between two sides of TEG will be challenging

6. REFERENCES

- [1] B.Praveena, A. Sowmiya, P.Logeshwari, Chaitanya Chiddarwar, "Thermo Electric Generator Module in Driving the Vehicle and Monitoring using IoT", Proceedings of the Second International Conference on Inventive Systems and Control (ICISC 2018).
- [2] Apurb Das, Rohith Kumar T, Gourishankar S, "A Novel Method for Modeling of Thermo Electric Coolers", 2017 7th International Conference on Power Systems (ICPS) College of Engineering Pune, India. Dec 21-23, 2017.
- [3] Rajkumar.V, JayaramDurgaManian, Hariharavarshan, "Recovering Energy from the exhaust heat in vehicles using Thermo Electric Generator", IEEE International conference on Circuit, power and computing technologies, 2015.
- [4] C. T. Hsu, G. Y. Huang, "An effective Seebeck coefficient obtained by experimental result so thermoelectric generator module," *Applied Energy*, vol. 88, pp. 5173–5179, Dec. 2011.
- [5] Andrea Montecucco, Jonathan Siviter, "The effect of temperature mismatch on the thermo electric generators electrically connected in series and parallel," *Applied Energy*, vol.123, pp. 47–54, Jun. 2014.