

Wireless Charging of Mobile Phones with Microwaves- A Review

Rohit Raj¹, Navneet Singh², Jagdeep Kaur³, Navdeep Kaur⁴

^{1,2}Assistant Professor, Gurdasdevi Institute of Management & Technology, Budhlada- India

^{3,4}Assistant Professor, KCT College of Engineering & Technology, Fatehgarh- India

Abstract - Currently mobile phones suitable a necessary part of days, the charging of mobile phone batteries contain forever been a difficulty. Mobile communication not only limited for voice transmission except as well use for a variety of multimedia application similar to convey of text, pictures, video etc. Public are argumentative to their mobile's battery life that they don't have lengthy battery life. They contain to charge their handset many periods. This is complete simply at what time present is a make use of microwave. The microwave rate of recurrence use is 2.45 GHz. We are by resources of the microwaves while the foundation of power. We contain to place in a sensor, a rectenna circuit along with a filer in our movable handset to do this work. Through addition these mechanism we be able to charge our phone via microwave while we talk. In this paper a novel thought exposed to charge your mobile phone lacking concerning its charger.

Key Words: Microwave, Wireless charging, Rectenna, Sensor, Transmitter, and magnetron.

1. INTRODUCTION

Here are two boss ideas which of this strategy, initial one is EM range and second is microwave area. The EM range is valuable to the individuals in very regards; it helps to choose the assortment of wavelengths.

The fluorescence contains every one of the areas of obvious range which has electromagnetic waves in it. Microwave be accommodating wavelength starting 1mm to 1m. The idiom microwaves identify with unpredictable current signal over frequencies among 300MHz and 300GHz. Microwave segments are regularly administered components, where the period of a voltage or current is change obviously in overabundance of the physical degree of the device since the device measurement be on the kind of microwave wavelength. Microwaves are EM power in wavelengths arrangement start as one meter to as short as one millimeter. The prefix smaller scale in the microwave is not predetermined toward prompt a wavelength inside the micrometer succession, it highlights to microwaves be pint-sized as think about toward the waves use in typical radio propagation; in this packaging they have shorter wavelengths.

Band Name	ITU Band	Frequencies	Wavelength
		Below 3 Hz	>100000 KM
ELU	2	3-30 Hz	100000 KM - 10000 KM
SLF	2	30-300 Hz	10000 KM - 1000 KM
ULF	3	300-3000 Hz	1000 KM - 100 KM
VLF	4	3-30 KHz	100 KM - 10 KM
LF	5	30-300 KHz	10 KM - 1 KM
MF	6	300-3000 KHz	1 KM - 100 M
HF	7	3-30 MHz	100 M - 10 M
VHF	8	30-300 MHz	10 M - 1 M
UHF	9	300-3000 MHz	1 M - 100 MM
SHF	10	3-30 GHz	100 MM - 10 MM
EHF	11	30-300 GHz	10 MM - 1 MM
		Above 300 GHz	< 1 MM

Fig 1: Electromagnetic Spectrum

Microwaves contain wavelengths to can be determined in centimeters. The more extended microwaves, people prior to a base in degree, are the waves which warmth our cooking inside a microwave oven.

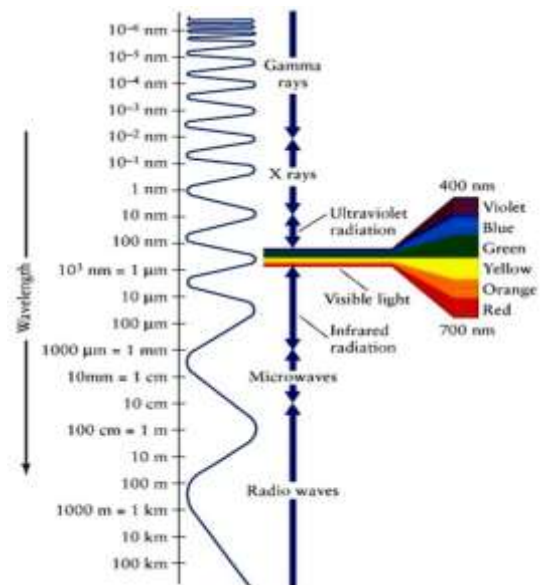

Fig 2: Electromagnetic Spectrum with Wavelengths

Microwaves are high-caliber for transmit in arrangement starting one situation to another, since microwave force can go over vapor, light rainstorm and snowstorm and smoke.

Shorter microwaves are utilized in remote detecting. These microwaves are utilized for mists and smoke, these waves are useful for observe the Earth from space Microwave waves are utilized in the transmission and in the microwave oven as a method to cook foodstuff. Microwave has huge frequency littler wavelength.

The microwave locale is additionally separated into the subsequent category. As of now we contain picked the approve complimentary 2.45 GHz ISM band implied for our goal. The industrialized, specialized, and therapeutic radio bands were firstly reserved universal for non-business use of RF electromagnetic fields for industrialized, orderly, and Aesculapian thought. The ISM bands are characterized by the ITU-T in S5.138 and S5.150 of the Radio exceptional to variety inside across the country radio strategy. In current presence they have too been used for permit-free blunder tolerant-based application, for example, Wi-Fi LANs in addition Bluetooth.

Designation	Frequency range
L Band	1 to 2 GHz
S Band	2 to 4 GHz
C Band	4 to 8 GHz
X Band	8 to 12 GHz
Ku Band	12 to 18 GHz
K Band	18 to 26 GHz
Ka Band	26 to 40 GHz
Q Band	30 to 50 GHz
U Band	40 to 60 GHz

Fig 3: Microwave region

2. WIRELESS TRASMISSION OF MICROWAVES

The microwave signal is transmitted from the transmitter along with the message signal using special kind of antennas called slotted wave guide antenna at a frequency of 2.45 GHz.

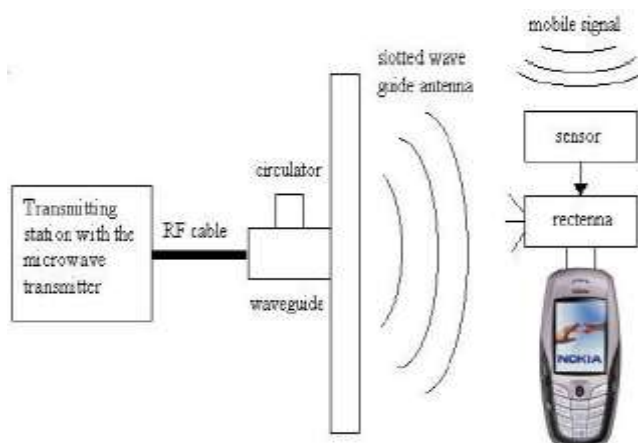

Fig 4: BD of wireless Transmission of microwaves

The microwave indicator is transmitting all along by means of communication sign use slot wave guide antenna. The sensor looks for the mobile sign, in count it has a rectenna. It receive the transmit power furthermore convert the microwave power in the direction of DC power. Wireless charger send an AC power warning sign en route for the

transmit coil. When the current is transferred through the coil an electromagnetic field is created around the coils, which when in range of another induction coil, the oscillating magnetic field creates a current in the receiving coil. Power container be transfer securely from side to side substance which live among the magnetic field create coils. The count of spare coils extends the selection at which the power preserve be inductively transferred. Energetic circuitry on the receiver convert the AC power signal addicted to DC voltage which can after that be second-hand to incriminate electronic devices all the way through batteries. It is this exact method used for charge pads plus industrial wireless solution.

3. COMPONMENTS OF WIRELESS CHARGING STRUCTURE

The components structure a system, execute function separately and together attain the system purpose. The a variety of components are there both at the transmitting plan and at the receiving design. The important components at transmitting side are the Microwave producer magnetron and the Transmitting antenna. The components by receiving ending are the Rectenna furthermore the sensory circuit.

3.1. Microwave Generator

The Microwave originator is the one which generate the microwave of favorite frequency. It generates the Microwave via the communication of condensation of elections and the magnetic field.

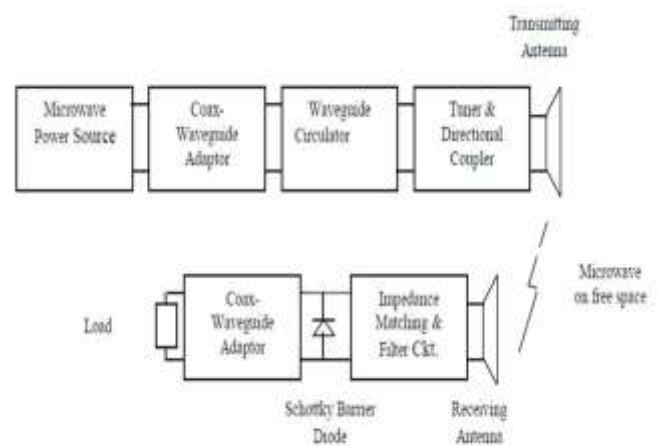

Fig 5: BD of Wireless power transmission

3.2. Magnetron

A magnetron is a diode vacuum tube with filament in which filament act as the cathode shown in fig. Magnetron is actually behaved as an oscillator to produce microwaves.

It can be done by putting magnet between the resonating chambers which is the center of the oscillator. These resonate chamber be named while anode here the magnetron.

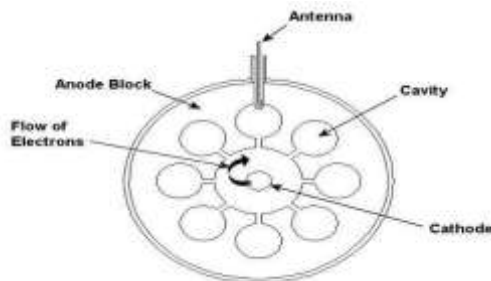

Fig 6: Magnetron

Once electrons move toward out from the cathode and go off straight towards the Anode; it passes from side to side the magnetic playing field. It start circulate in the resonate hole and begin produce waves according to its regularity and the generate RF signal by means of this flow exterior of the cavity.

3.3. Transmitting Antenna

Transmit antenna be employ to move the signal beginning free gap to the apparatus. Present are numerous type of slot wave guide antenna obtainable. Similar to parabolic dish antenna, micro strip patch antennas are the well-liked kind of transmitting antenna.

3.4. Rectenna

A rectenna be a rectify antenna, an extraordinary category of antenna so as to be used to adapt microwave power addicted to through current electrical energy shown in fig:7

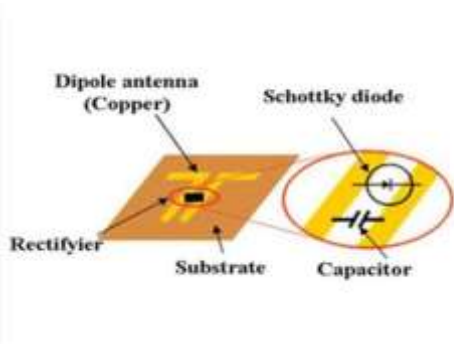

Fig 7: Rectenna system

Its elements are usually agreed in a web model, giving it a separate facade from the majority antennae. The current

built-in by the microwaves in the antenna is rectifying as a outcome of the diode which powers a load associated crosswise the diode.

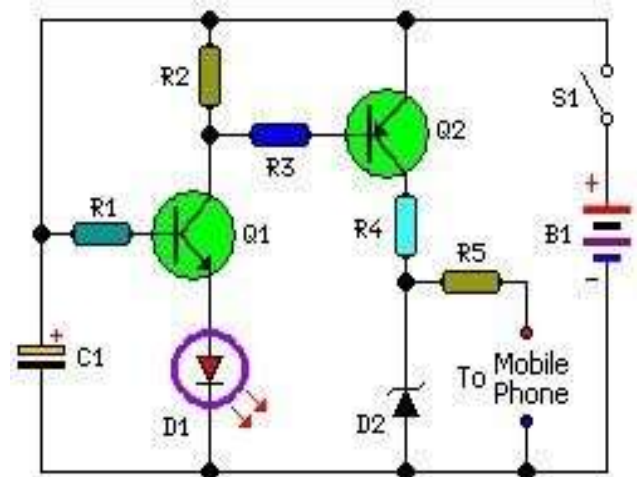

Fig 8: The schematic representation of rectenna

Schottky diodes are used because they have low voltage drop and high speed so that they have low power loss. Rectenna are extremely well-organized at convert microwave force to electricity. During laboratory environment, efficiencies higher than 90% include were experiential with reliability.

3.5. Receiver

The essential adding up to the movable phone is going away to be the rectenna. A rectenna is a rectify aerial, a particular kind of antenna with the intention of worn to in a straight line exchange microwave energy hooked on DC electrical energy. Really the extent of rectenna can be dropping using the Nano skill. We as well have to include a feeler at receiver part. Like we be familiar with we are disappearing to charge the phone whilst a person is talk. Consequently at this time sensor be use to sense wither the phone is using microwaves or else not.

3.6. Sensory Circuit

Sensor circuit is a sensor employed at receiver side which is required for the detection of message signals while on call because microwaves are available during that time and mobile phone has to get charged as long as the sensor detects the message signals. The feeler output the being there of message signals to the rectenna i.e. the sensor workings in frontage of rectenna as an pointer of the existence of microwaves.

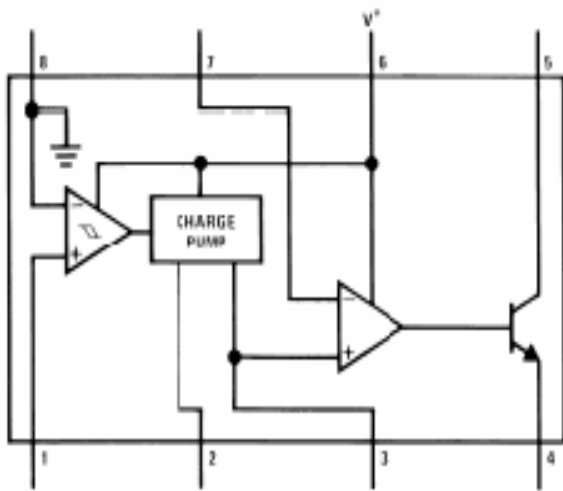

Fig 9: Block diagram of LM2907

Thus a simple frequency to voltage convert would serve our purpose. This converter would do something like switches to activate the rectenna circuit to on. Therefore while our handset is receiving microwave signal it build the rectenna circuit on and charge the battery. At this juncture in India the working frequency of the GSM is 900 MHz to 1800 MHz. We be able to use LM2907 meant for F to V exchange. So on the reception of the gesture the feeler circuitry direct the rectenna circuit to ON along with the mobile phone begin to accuse with the microwave power.

4. SUCCINCT PREFACE OF SCHOTTKY BARRIER DIODE

A Schottky barrier diode is dissimilar starting a universal P/N silicon diode. The general diode is created by linking a P type semiconductor among an N type semiconductor; this is involving stuck between semiconductors moreover one more semiconductor; but, a Schottky barrier diode is fashioned by relating a metal with a semiconductor. As soon as the metal associates the semiconductor, present will be a coating of possible barrier shaped on the get in touch with surface of them, which show a quality of modification.

A Schottky barrier diode is a mainstream carrier device, whereas a universal diode is a marginal carrier device. After a common PN diode is twisted beginning electric involving to circuit crack, the unneeded minority carrier on the make contact with surface be supposed to be impassive to product in time delay. Various Schottky barrier diodes: Small signal RF devices, medium and high power Schottky rectifying diodes.

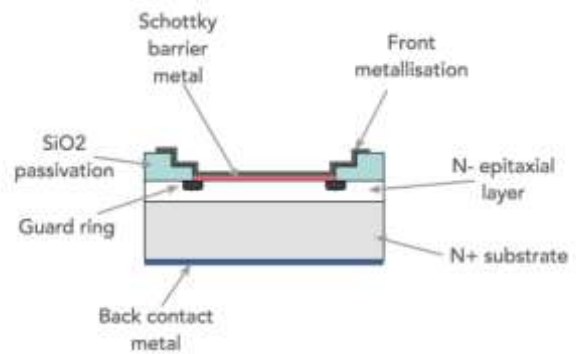

Fig 10: The Schottky Diode Work

While current flow during a diode here is a tiny voltage go down crosswise the diode terminal. A usual silicon diode has a voltage drop involving 0.6–1.7 volts, while a Schottky diode voltage jump down is amid just about 0.15-0.45 volts. This lower voltage drop can provided high switching speed and better system efficiency. The Schottky barrier diode itself have no minority carrier, it preserve rapidly twist from electric linking to circuit breakage, its speed is a great deal quicker than a common P/N diode, so its overturn recovery time T_{rr} is incredibly small and shorter than 10 ns and the forward voltage bias of the Schottky barrier diode is underneath 0.6V or so, worse than that about 1.1V of the common PN diode. So, The Schottky barrier diode be a relatively supreme diode, such as designed for a 1 ampere imperfect current PN boundary.

5. ADVANTAGE

Make use of split chargers is eliminated. Electrical energy is saved. The handset can be charged anyplace anytime. Lesser hazard of electrical upset for the reason that here are no uncovered conductors. Easier than plugging interested in a power wire. Out of harm's way intended for medical implant in favor of embedded medical strategy allow recharging throughout skin to a certain extent than having wires go through skin. It does not have need of wire in support of charging.

6. DRAWBACKS

This structure wants a piece of equipment rectenna which ought to be of molecular dimension or else the portable devices would turn out to be immense. The charging effectiveness decrease by means of the enlarged space among two sides .The charging strategy contains been establishing heating up rapidly than the through make contact with electrical energy. In addition the microwaves are extremely dangerous as well as can reason severe problem in human like falls. The effort intended for humanizing the effectiveness is obtainable.

7. CONCLUSION

As a result this effort fruitfully demonstrate a work of fiction method of by means of the power of the microwave in the way of charge the mobile phone lacking the utilize of wired chargers. Hence this way provides immense benefit toward the mobile phone user to take their phones everyplace still if the position is devoid of services in favor of charging.

A narrative utilizes of the rectenna in addition to a sensor in a mobile phone might give a new height in the surprise of mobile phone. Depending going on the features they propose these be accessible into dissimilar worth ranges, you can acquire the one that suit you the most excellent.

REFERENCES

- [1] Yoo, T-W., and Kai Chang. "Theoretical and experimental development of 10 and 35 GHz rectennas." *IEEE Transactions on Microwave Theory and Techniques* 40.6 (1992): 1259-1266.
- [2] Mohammed, S. Sheik, K. Ramasamy, and T. Shanmuganantham. "Wireless power transmission—a next generation power transmission system." *International journal of computer applications* 1.13 (2010): 100-103.
- [3] McSpadden, James O., and Kai Chang. "A dual polarized circular patch rectifying antenna at 2.45 GHz for microwave power conversion and detection." *1994 IEEE MTT-S International Microwave Symposium Digest (Cat. No. 94CH3389-4)*. IEEE, 1994.
- [4] Rewaskar, Priya A., and Dinesh Datar. "Wireless charging of mobile phone using microwave." *International Journal of Computer Science and Mobile Computing* 3.4 (2014): 427-432.
- [5] Reddy, M. Venkateswara, K. Sai Hemanth, and CH Venkat Mohan. "Microwave power transmission—a next generation power transmission system." *IOSR Journal of Electrical and Electronics Engineering (IOSRJEEE)*, e-ISSN (2013): 2278-1676.
- [6] Chang, Kai. *Encyclopedia of RF and microwave engineering*. Ed. John Wiley. John Wiley, 2005.
- [7] McSpadden, James O., et al. "An in-space wireless energy transmission experiment." *IECEC 96. Proceedings of the 31st Intersociety Energy Conversion Engineering Conference*. Vol. 1. IEEE, 1996.
- [8] Shinohara, Naoki, and Shigeo Kawasaki. "Recent wireless power transmission technologies in Japan for space solar power station/satellite." *2009 IEEE radio and wireless symposium*. IEEE, 2009.
- [9] Harrist, Daniel Wesley. *Wireless battery charging system using radio frequency energy harvesting*. Diss. University of Pittsburgh, 2004.
- [10] Sivaramakrishnan, Ajay, and Kailarajan Jeyaprakash Jegadishkumar. "A highly efficient power management system for charging mobile phones using RF energy harvesting." *International Journal of Information Technology Convergence and Services* 1.5 (2011): 21.
- [11] Lin, James C. "Wireless power transfer for mobile applications, and health effects [telecommunications health and safety]." *IEEE Antennas and Propagation Magazine* 55.2 (2013): 250-253.
- [12] Lu, Xiao, et al. "Wireless charger networking for mobile devices: Fundamentals, standards, and applications." *IEEE Wireless Communications* 22.2 (2015): 126-135.
- [13] <http://en.wikipedia.org/wiki/Rectenna>
- [14] [http://en.wikipedia.org/wiki/Introduction to Microwave](http://en.wikipedia.org/wiki/Introduction_to_Microwave).
- [15] www.scribd.com
- [16] www.seminarsonly.com