

Review: Different Techniques for ARC flash and Fault Analysis and Classification

Kalyani Rajesh Fulzele¹, P.P. Gajbhiye², V.M. Jape³

¹PG Scholer, Government College of Engineering, Amaravti, Maharashtra, India

²Assistant Professor, Dept. of Electrical Engineering, Government college of Engineering, Amaravti, Maharashtra, India

³Assistant Professor, Dept. of Electrical Engineering, Government college of Engineering, Amaravti, Maharashtra, India

Abstract - Photovoltaic systems have increased in both the quantity of installations and the size of installations over the past decade. As more utility-run systems are being constructed, it is important to consider the safety of operators and maintenance crew during the design and analyses phases. Unfortunately, one potential safety hazard, the electrical arc-flash, is not well understood for photovoltaic systems. The thermal energy released by this hazard can be significant, especially in large photovoltaic systems operating at high voltages and current. The focus of this paper is on dc PV grid system arc flash or fault location. Simulation models are synthesized to study the theoretical results of the proposed methodology and traditional fast Fourier transform analysis on arcing faults. Experimental data from the dc system of a photovoltaic array is also shown to validate the approach.

Key Words: Arc flash, Arc fault, Classification, Analysis etc.

1. INTRODUCTION

It is important to understand the potential hazards that can occur in a power system to ensure the safety of the system operators. Considerations of one such hazard, the electric arc-flash, have increased within the last few decades for electrical construction projects with high power densities such as data centers. Governmental ordinances and facility owners are mandating that system designers include risk-category evaluations for this hazard in their analyses to determine the appropriate safety labeling for the equipment that are most at risk. Such labeling would alert operators to the potential dangers that can occur and inform them of the type of personal protection equipment (PPE) that is necessary when working on the corresponding equipment during live conditions.

Most electrical power distribution is done with 3-phase AC, especially within buildings and facilities. As a result, most studies involving arc-flashes have focused on 3-phase AC systems. It has been found that the early AC arc-flash calculation models [1], largely based on fundamental electrical and thermal theory, exaggerated the strength of these hazards. Therefore, the calculations used in industry have been refined over the years to provide more realistic estimates for practical systems by including empirical data gathered in the field [2].

The increased use of DC in industrial sites and discussion of its use in data centers [3], [4] has prompted the need to develop accurate calculation models for estimating DC arc flashes. Thus far, researchers have presented models [5], [6] using approaches similar to those used when creating the early AC arc-flash models. These DC models may exaggerate the thermal conditions similar to the early AC arc-flash models, however they allow for a preliminary understanding of the potential magnitude of these hazards in DC systems.

2. DIFFERENT TECHNIQUES FOR ARC FAULT ANALYSIS AND CLASSIFICATION

Photovoltaic systems have increased in both the quantity of installations and the size of installations over the past decade. As more utility-run systems are being constructed, it is important to consider the safety of operators and maintenance crew during the design and analyses phases. Unfortunately, one potential safety hazard, the electrical arc-flash, is not well understood for photovoltaic systems. The thermal energy released by this hazard can be significant, especially in large photovoltaic systems operating at high voltages and currents. This method examines the conditions surrounding electric arc flashes in photovoltaic systems based on typical designs [1]. Using existing models for DC arc-flashes and basic circuit theory, equations and analysis techniques are developed to estimate the thermal energy that can be released if these hazards were to occur. These techniques can be used to determine the hazard risk category for the system components most at risk, until more empirical models are developed [14].

As photovoltaic installations increase in quantity and design capacities it is important to develop better understandings of the safety hazards associated with these systems. The understanding of one such hazard: the DC electric arc-flash has been slow in propagation. However, the estimation models and analyses techniques developed for DC arcs thus far do not accurately characterize these hazards in PV systems [13].

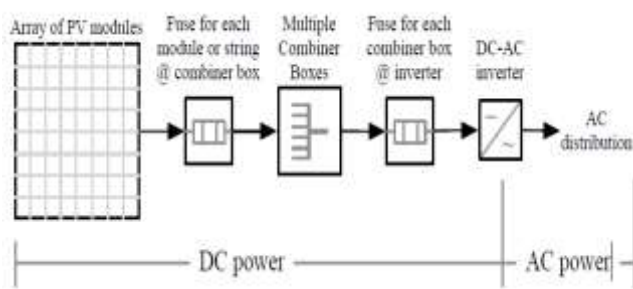

Fig-1. Typical components of a DC power block in an on-grid PV system

This method presented a series of calculation models and analyses approaches that can be used for preliminary estimation of the thermal dangers of these hazards. The models developed were based upon existing DC electric-arc models and the typical characteristics of practical PV systems. It is expected that these models would be refined once more data is gathered from field-testing and experimentation.

One of methodology presents a dc arc model to simplify the study of a critical issue in dc microgrids: series faults [2]. The model is derived from a hyperbolic approximation [16] of observed arc voltage and current patterns, which permit analyzing the arc in terms of its resistance, power, energy, and quenching condition. Recent faults staged by the authors on a dc microgrid yielded enough data to develop an arc model for three fault types: constant-gap speed, fixed-gap distance, and accelerated gap. The results in this paper compare experimental and simulation results for the three fault types. It is concluded that because the instantaneous voltage, current, power, and energy waveforms produced by the model agree well with experimental results, the model is suitable for transient simulations.

Although no two data sets are identical [15], even under nominally the same environmental and electrical conditions, there is an underlying common behavior. While the exact magnitude and position of the individual spikes appear to be random, there is a consistent decrease in the gap current and increase in the gap voltage with time. The other apparently random feature is the gap spacing x_{crit} at which the arc initiates rapid extinction.

This technique is focused on low-frequency, spectral and correlation analysis to serial arc fault electrical system in order to detect arc fault [3]. This analysis can be used to improve the security of power supplies in the automotive, aerospace and photovoltaic systems. More precisely, we study the influence of arc ignition on the signal characteristics. The experimental test bench is composed by an arc generator, a robotic cylinder and different loads. Three types of arcs ignitions are considered: carbonized path, contact opening and over-voltage. 0.5 kHz - 500 kHz spectrum is measured before and during the start phase of the arc and stabilization. The results show the possibility to

determine the cause of the arc fault ignition. The shape of low frequency arc voltage is estimated from the current measurement with a very high fidelity where the load is known. Finally study the possibility to locate series arcs by analyzing the correlation function of the Radio Frequency (RF) signals from two Rogowski coils inserted at two distinct points of the circuit. The calibration procedure performed reveals a mean velocity in the system of about 24 cm/ns.

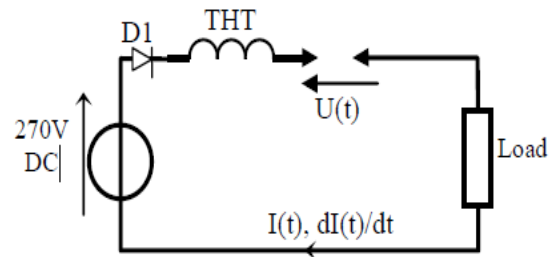

Fig-2. Test circuit with over-voltage ignition

Finally, the result of cross-correlation has been used to locate or not arc fault. RF signals from two Rogowski coils and cross-correlation algorithm are has been used to determine an event in the circuit and the localization of this event [17].

Arc faults have always been a concern for electrical systems, as they can cause fires, personnel shock hazard, and system failure. Existing commercialized techniques that rely on pattern recognition in the time domain or frequency domain analysis using a Fourier transform do not work well, because the signal-to-noise ratio is low and the arc signal is not periodic. Instead, wavelet transform (WT) provides a time and frequency approach to analyze target signals with multiple resolutions. In this technique, a new approach using WT for arc fault analysis in dc systems is proposed [4]. The process of detecting an arc fault involves signal analysis and then feature identification. The focus of this method is on the former. Simulation models are synthesized to study the theoretical results of the proposed methodology and traditional fast Fourier transform analysis on arcing faults. Experimental data from the dc system of a photovoltaic array is also shown to validate the approach.

The presence of switching harmonics and ambient electrical noise can mask the arc signal, making detection of an arc difficult. Fourier analysis is usually not able to discover transient signals and abrupt changes like sudden arc faults and arc flashes. If the duration of the arc flash lasts for a very short period of time in comparison with the sampling window of FFT [18], it is likely that the arc flashes will not be observable.

However, WT is extraordinarily effective with detecting the exact instant the signal changes. The results suggest that the WT approach is not just capable of analyzing arc fault in dc systems but that it also provides a more

readily detectable signal and better performance than the FFT method.

Compared to conventional AC grids, DC microgrids demand different switchgear and safety concepts. Electric arcs across mechanical contacts of circuit breakers during switching operations and also arc faults within the installation are more stable in the case of continuous current. Model based methods are important tools not only for selecting the appropriate method of converter control [5], but also for analyzing the boundary conditions for faults and to develop reliable arc fault detection devices.

Online system identification and machine learning methods will be developed to be implemented in electronic circuit breakers to gain more precise information of the monitored system and its range of working points. With an integrated system model it should be possible to identify different kinds of faults, like shortcuts, gradual malfunction and also arcs in an earlier stage compared to conventional protection devices; a better prevention against further damage of the grid and its components can be gained [19].

The technology of a series arc-fault detection algorithm for photovoltaic (PV) systems, which relies on the quantum probability model theory [6]. The algorithm determines the presence of the arc by calculating the modified Tsallis entropy of the PV panel current. Based on the calculated entropy, the algorithm is able to differentiate an arc state (when the current variations are chaotic) from a no-arc state (when the current variations are ordered). The proposed algorithm enables arc-fault detection on a plug-and-play principle, requiring no prior information about the PV system in which it operates. The operation of the algorithm was first simulated on the prerecorded data from the system with the PV panel simulator and the commercial PV inverter. A laboratory prototype of the detector was then built and tested in a real 1.6 kW grid-connected PV system with different PV inverter, without any additional parameter adjustments. [20] Both the sensitivity and the robustness of the detector were confirmed. The tests have shown that both the sustained series arcs and the small sparking series arcs were successfully detected and there was no false detection due to the MPP tracker operation, PV current step change, or inverter turn on transient.

The main advantage of the proposed algorithm, compared to the algorithms that are based on the frequency spectrum monitoring, is that the noise signature of the target PV system, as well as the manual calibration of the detector's parameters are not required for its proper operation. The proposed algorithm is also less computationally expensive than FFT-based algorithms, so it can reduce the cost of the overall product.

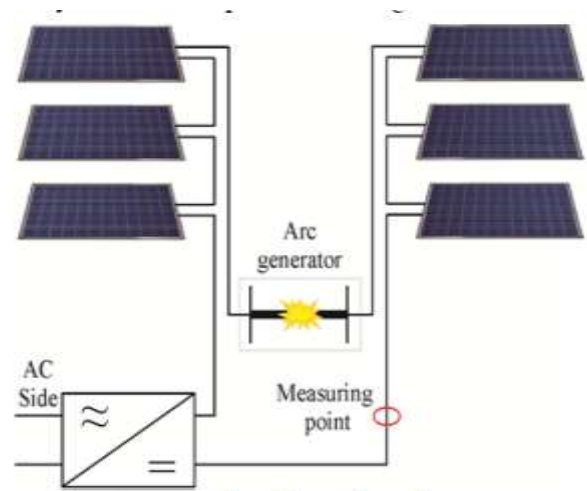

Fig.-3. Schematic representation of the experimental setup

In this method, the operation of the detection algorithm was simulated on a set of prerecorded data from the commercial single phase 3.3 kW inverter and PV panel simulator, taken at 5 different loads. The detector prototype was then built and its operation was experimentally verified in a grid-connected 1.6 kW PV system, without any prior analysis of the target PV system or any additional algorithm parameter adjustments. During experimental evaluation, input signal of detector prototype is recorded and internal parameters of algorithm are reconstructed on computer. Analysis of internal parameters revealed modest sensitivity to current step change and large current spike during turn on transient, and confirmed efficiency in SEA detection.

Arc faults pose significant reliability and safety issues in today's photovoltaic (PV) systems. This methodology presents an effective method based on wavelet transform and support vector machines (SVM) for detection of arc faults in DC PV systems. Because of its advantages in time-frequency signal processing, wavelet transform is applied to extract the characteristic features from system voltage/current signals. [21] SVM is then used to identify arc faults. The performance of the proposed technique is compared with traditional Fourier transform based approaches.

This approach proposes a technique for arc fault detection in photovoltaic systems by using discrete wavelet transform for feature extraction and support vector machine for decision making. Since the developed classifier is designed for real-time DSP/MCU applications, the computation load involved in the classification and the memory space used for support vector storage are two major concerns.

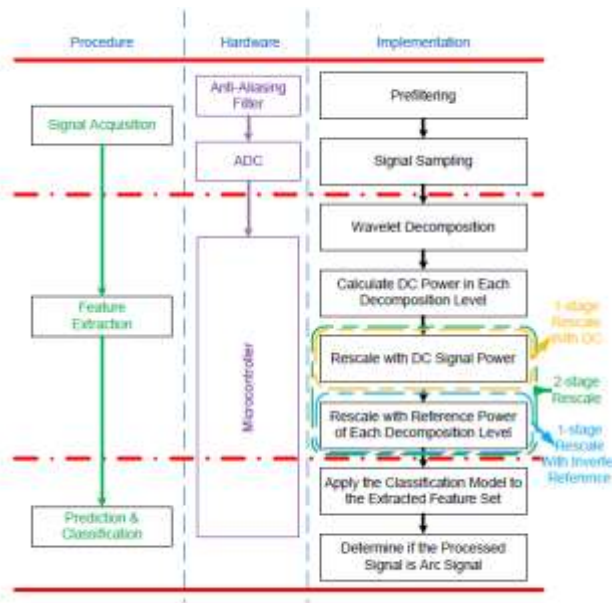

Fig.-4. Work flow of the proposed hardware implementation [7]

Thus, only linear SVM was considered in this paper. It has been shown that the rescaling strategy of the feature extraction plays a significant role in the entire classifier development. In this method, a 2-stage rescaling strategy is found to be efficient to provide linear separation between the two classes for the extracted feature set to be linearly separable.

This method describes a detection algorithm for series dc arc faults to improve safety issues in dc microgrids. Series arc faults typically occur when gaps form in a current flowing wire or contactor. Arc faults can create serious fire hazards if not detected and removed in a short time. To identify series arc faults accurately and quickly in dc microgrids, a series dc arc fault detection algorithm using relative magnitude comparison is proposed. The proposed algorithm detects the time of occurrence of an arc fault based on the magnitudes of the load current in both the time and frequency domains simultaneously. The algorithm works accurately in a dc microgrid with multiple switching converters, as it relies only on relative current information. The proposed detection algorithm is experimentally verified on a 5 kW 380 V dc microgrid prototype with an arc fault generation unit.

The proposed algorithm detects a series arc fault candidate point using a gradient computation in the time domain and then compares the relative frequency-domain magnitude differences in the load current around the candidate point. The candidate point is designated as a series arc fault occurrence point when the magnitudes of the frequency spectrum are significantly increased.

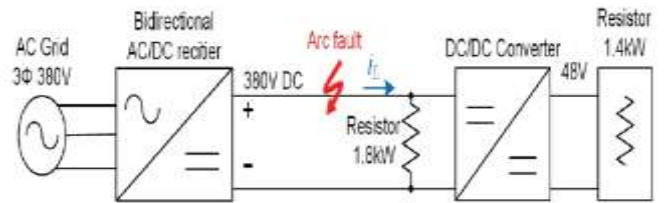

Fig.-5. Simple series dc arc fault test circuit [8]

Increasing prevalence of dc sources and loads has resulted in dc distribution being reconsidered at a microgrid level [9]. However, in comparison to ac systems, the lack of a natural zero crossing has traditionally meant that protecting dc systems is inherently more difficult—this protection issue is compounded when attempting to diagnose and isolate fault conditions. One such condition is the series arc fault, which poses significant protection issues as their presence negates the logic of over-current protection philosophies. This technique proposes the IntelArc system to accurately diagnose series arc faults in dc systems. Intel Arc combines time-frequency and time-domain extracted features with hidden Markov models (HMMs) to discriminate between nominal transient behavior and arc fault behavior across a variety of operating conditions. Preliminary testing of the system is outlined with results showing that the system has the potential for accurate, generalized diagnosis of series arc faults in dc systems [22].

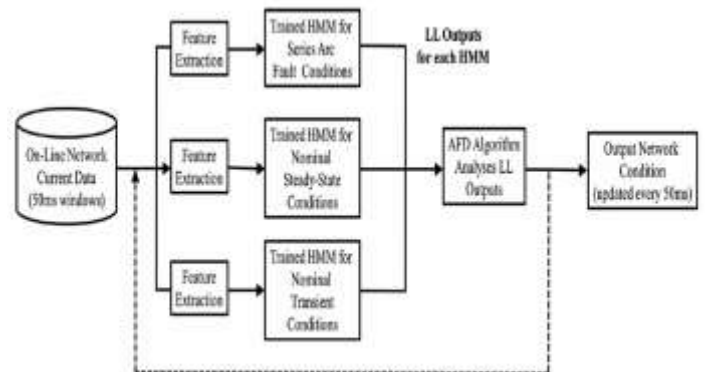

Fig.-6. Outline of Intel Arc method [9]

Accelerating Intel Arc through technology readiness levels (TRL) will require further consideration of the effect that noise emissions and interference from system devices have on detection accuracy. Deployment within compact dc networks, with current sensors located at the closest upstream bus bar, means that transmitted fault signals and data should remain uncorrupted. However, further consideration will also be given to this issue at higher TRL.

This technique [10] aims at providing a reliable algorithm to identify photovoltaic (PV) series arc faults regardless of complex fault-like interferences. Through conducting various arc fault experiments with different PV

current levels, arc gap lengths, and load types, PV series arc fault features have been understood comprehensively. To avoid unwanted nuisance tripping, fault-like conditions are analyzed to confirm the unique arc fault features. Based on the loop current signature, a greater unstable fluctuation in the time domain and extra arc noises in the time-frequency domain are chosen as identification features. By quantificational evaluations, optimal detection variables with the Hamming window and the proper time resolution have been established to achieve the best identification results. By building fusion coefficients, two variables are arithmetically fused to achieve the arc fault discovery. The algorithm could also classify fault-like into normal and adjust the threshold value dynamically to fit different normal current levels. Its validity has been verified by experimental results on the simulated platform. PV series arc faults lead to the system operation point changes while the MPPT in switching devices restores the original system operation point. With synthetic effects of the MPPT, the fault loop current increases to almost the same level as the normal current.

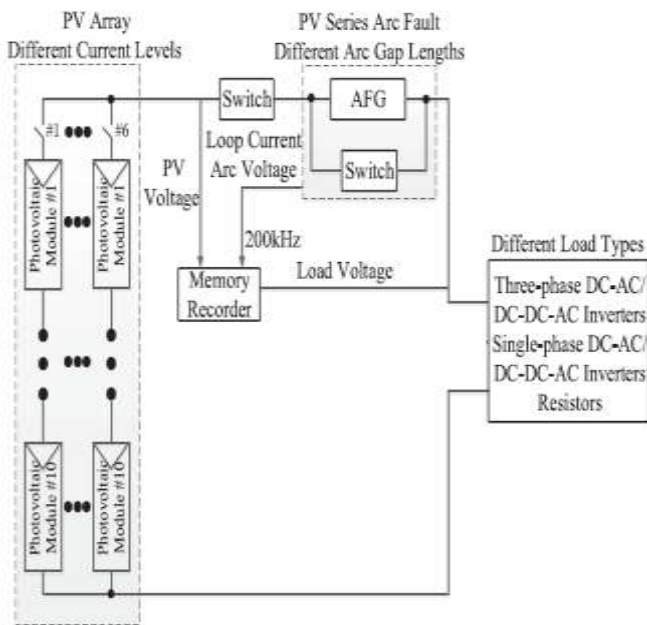

Fig-7. Experiment schematic of PV series arc fault with different PV system and series arc fault factors [10]

Possible fault-like conditions from the PV array, load power, and dc switch state changes display the three-stage form. Viewed from the decrease shape, these conditions are classified into fast, abrupt, and slow variations. For less human regulations, PV system transitions by the weather are more likely to cause nuisance tripping.

High impedance faults (HIFs) are easy to occur in collective feeders in wind farms and may cause the cascading of wind generators tripping. This kind of faults is difficult to be detected by traditional relay or fuse due to the limited fault current values and the situation is worse in wind farms.

The mostly adopted HIF detection algorithms are based on the 3rd harmonic characteristic of the fault zero-sequence currents, whereas these 3rd harmonics are very easy to be polluted by wind power back-to-back converters. In response to this problem, the typical harmonic characteristic of HIF arc flash based on Mayr's arc model is first analyzed, and the typical fault waveforms of HIF in wind farm are presented. Then the performance of the harmonic based HIF detection algorithm is discussed, and a novel detection algorithm is proposed from the viewpoint of time domain, focusing on the convex and concave characteristic of zero-sequence current at zero crossing points. A HIFs detection (HIFD) prototype implementing the proposed algorithm has been developed [11]. The sensitivity and security of the algorithm are proved by field data and RTDS experiments.

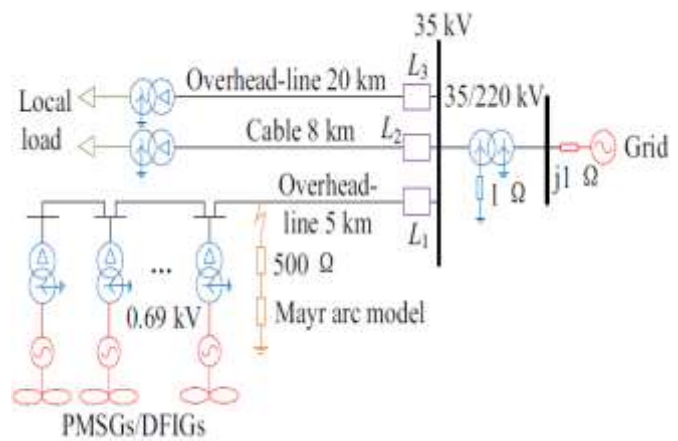

Fig-8. Simulation circuit of HIF in wind farm [11]

Arc faults threaten the safe operation of photovoltaic (PV) systems. An arc fault detection and localization approach using parallel capacitors is proposed [12]. A PV system has been analyzed and tested with five capacitors paralleled with the branches in the system. Series and parallel arc faults at nine locations have been tested in the system. When an arc occurred, current pulses were generated in the capacitors and their amplitudes and polarities were obtained through Hall current sensors. Discrete wavelet transformation was performed on the capacitor currents and the distributions of their amplitudes, frequency spectrums, and polarities are here reported. The results indicate that the distributions are unique under different fault types and locations, which could be used to detect and localize arc faults in PV systems. Moreover, the amplitudes of the capacitor currents can also help to localize a series arc fault within a PV string. Finally, the proposed approach is validated by a double-fault test.

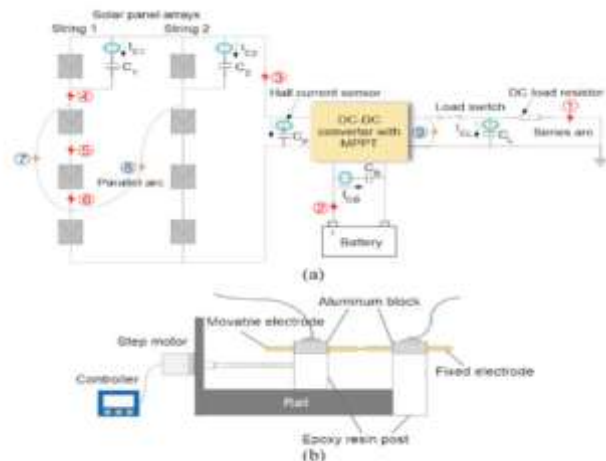

Fig.-9. Test circuit and arc generation setup. (a) Test circuit. (b) Arc generation setup [12]

3. PLANNING APPROACH

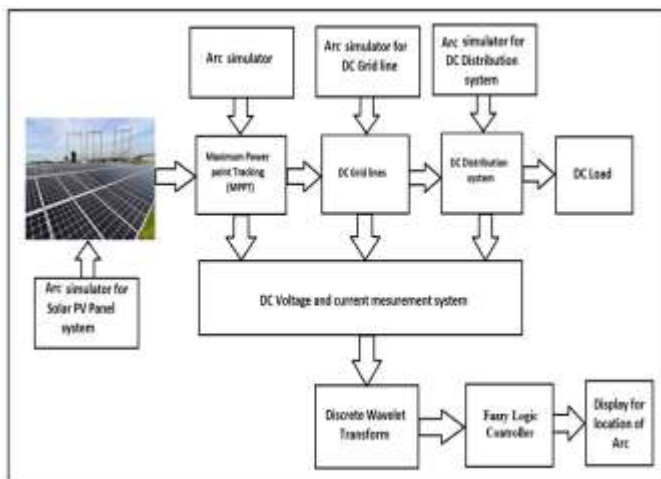

Fig.-10. Block diagram of planning approach

We will propose one of the methodologies in which Arc fault or flash location at a different location on the DC grid or solar PV system. For that Cassie arc model utilized for arc generation at different locations of DC grid line or solar PV dc line. The Cassie arc model is connected at different location of dc grid and which is consider as slandered arc model for dc grid system for different locations. Then the voltage of the dc grid will be measured at the end of the line and then the measured voltage will be transfer to a discrete wavelet transform using Haar mother wavelet for signal energy calibration.

Then calibrated spectral energy will be utilized for designing the fuzzy rule base designing. Also utilized for designing of input membership functions and output membership function for the fuzzy logic controller which will act as a classifier for arc flash locations on the dc grid. This complete system will be designed in MATLAB Simulink software. So we have planned to design such system in the future in MATLAB Simulink software.

4. CONCLUSION

This paper is reviewing the different techniques for arc fault or arc flash analysis or classification on the DC grid or PV system or wind turbine grid system. This paper will be very much useful for researches or students who are interested or done research or project work in arc flash or arc-fault conditions on the dc grid system. After review different technology we will also introduce a new technique in the future for arc flash or fault location classification using a discrete wavelet transform and fuzzy logic controller.

REFERENCES

- [1] Yuventi, Jumie. "Electric arc-flash energy calculations for photovoltaic systems." 2012 IEEE 38th Photovoltaic Specialists Conference (PVSC) PART 2. IEEE, 2012.
- [2] Uriarte, Fabian M., et al. "A DC arc model for series faults in low voltage microgrids." IEEE Transactions on smart grid 3.4 (2012): 2063-2070.
- [3] Rabla, Michael, et al. "Arc fault analysis and localisation by cross-correlation in 270 V DC." 2013 IEEE 59th Holm Conference on Electrical Contacts (Holm 2013). IEEE, 2013.
- [4] Wang, Zhan, and Robert S. Balog. "Arc fault and flash signal analysis in DC distribution systems using wavelet transformation." IEEE Transactions on Smart Grid 6.4 (2015): 1955-1963.
- [5] Strobl, Christian. "Arc fault detection in DC microgrids." 2015 IEEE First International Conference on DC Microgrids (ICDCM). IEEE, 2015.
- [6] Georgijevic, Nikola L., et al. "The detection of series arc fault in photovoltaic systems based on the arc current entropy." IEEE Transactions on Power Electronics 31.8 (2015): 5917-5930.
- [7] Wang, Zhan, and Robert S. Balog. "Arc fault and flash detection in photovoltaic systems using wavelet transform and support vector machines." 2016 IEEE 43rd Photovoltaic Specialists Conference (PVSC). IEEE, 2016.
- [8] Chae, Suyong, Jinju Park, and Seaseung Oh. "Series DC arc fault detection algorithm for DC microgrids using relative magnitude comparison." IEEE Journal of Emerging and Selected Topics in Power Electronics 4.4 (2016): 1270-1278.
- [9] Telford, Rory David, et al. "Diagnosis of Series DC Arc Faults—A Machine Learning Approach." IEEE Transactions on Industrial Informatics 13.4 (2016): 1598-1609.

- [10] Chen, Silei, Xingwen Li, and Jiayu Xiong. "Series arc fault identification for photovoltaic system based on time-domain and time-frequency-domain analysis." *IEEE Journal of Photovoltaics* 7.4 (2017): 1105-1114.
- [11] Bin, W. A. N. G., et al. "Arc flash fault detection in wind farm collection feeders based on current waveform analysis." *Journal of Modern Power Systems and Clean Energy* 5.2 (2017): 211-219.
- [12] Xiong, Qing, et al. "Arc fault detection and localization in photovoltaic systems using feature distribution maps of parallel capacitor currents." *IEEE Journal of Photovoltaics* 8.4 (2018): 1090-1097.
- [13] A. Lazkano, J. Ruiz, E. Aramendi, and L. A. Leturiondo, "Evaluation of a new proposal for an arcing fault detection method based on wavelet packet analysis," *Eur. Trans. Elect. Power*, vol. 14, no. 3, pp. 161-174, May/June. 2004.
- [14] G. D. Gregory and G. W. Scott, "The arc-fault circuit interrupter, an emerging product," in *Proc. IEEE Ind. Commer. Power Syst. Tech. Conf.*, Edmonton, AB, Canada, 1998, pp. 48-55.
- [15] G. Yunmei, W. Li, W. Zhuoqi, and J. Binfeng, "Wavelet packet analysis applied in detection of low-voltage DC arc fault," in *Proc. 4th IEEE Conf. Ind. Electron. Appl. (ICIEA)*, Xi'an, China, 2009, pp. 4013-4016.
- [16] F. M. Uriarte et al., "A DC arc model for series faults in low voltage microgrids," *IEEE Trans. Smart Grid*, vol. 3, no. 4, pp. 2063-2070, Dec. 2012.
- [17] L. Zhigang, G. Rong, L. Jun, and A. Huang, "A high-efficiency PV module-integrated DC/DC converter for PV energy harvest in FREEDM systems," *IEEE Trans. Power Electron.*, vol. 26, no. 3, pp. 897-909, Mar. 2011.
- [18] H. Zhang, T. Chen, and W. Li, "Arc fault signatures detection on aircraft wiring system," in *Proc. 6th World Congr. Intell. Control Autom.*, Dalian, China, 2006, pp. 5548-5552.
- [19] K. Koziy, B. Gou, and J. Aslakson, "A low-cost power-quality meter with series arc-fault detection capability for smart grid," *IEEE Trans. Power Del.*, vol. 28, no. 3, pp. 1584-1591, Jul. 2013.
- [20] C. E. Restrepo, "Arc fault detection and discrimination methods," in *Proc. 53rd IEEE HOLM Conf. Elect. Contacts*, Pittsburgh, PA, USA, 2007, pp. 115-122.
- [21] W.-J. Li and Y.-C. Li, "Arc fault detection based on wavelet packet," in *Proc. 4th Int. Conf. Mach. Learn. Cybern.*, vol. 3. Guangzhou, China, 2005, pp. 1783-1788.
- [22] J. Johnson et al., "Differentiating series and parallel photovoltaic arc-faults," in *Proc. 38th IEEE Photovolt. Spec. Conf. (PVSC)*, Austin, TX, USA, 2012, pp. 3-8.
- [23] Y. Xiu, J. Shengchang, L. Herrera, and W. Jin, "DC arc fault: Characteristic study and fault recognition," in *Proc. 1st Int. Conf. Elect. Power Equip. Switch. Technol. (ICEPE-ST)*, Xi'an, China, 2011, pp. 387-390.
- [24] W. Zhao, Y. H. Song, and Y. Min, "Wavelet analysis based on scheme for fault detection and classification in underground cable systems," *Elect. Power Syst. Res.*, vol. 53, no. 1, pp. 23-30, Jan. 2000.
- [25] W. Li, A. Monti, and F. Ponci, "Fault detection and classification in medium voltage DC shipboard power systems with wavelets and artificial neural networks," *IEEE Trans. Instrum. Meas.*, vol. 63, no. 11, pp. 2651-2665, Nov. 2014.
- [26] J. L. Guardado, S. G. Maximov, E. Melgoza, J. L. Naredo, and P. Moreno, "An improved arc model before current zero based on the combined Mayr and Cassie arc models," *IEEE Trans. Power Del.*, vol. 20, no. 1, pp. 138-142, Jan. 2005.
- [27] S. McConnell, W. Zhan, R. S. Balog, and J. Johnson, "Evaluation method for arc fault detection algorithms," in *Proc. IEEE 40th Photovolt. Spec. Conf. (PVSC)*, Denver, CO, USA, 2014, pp. 3201-3206.