

Study and Design of Desalination Plant for Surat City

Alish Patel¹, Khushbu Gandhi²

¹Student of ME Structural Engineering at Sarvajani College of Engg. & Technology

²Assistant Professor at Sarvajani College of Engg. & Technology, Gujarat, India

Abstract - As 70% of the world is covered by water, only 2.5% of it is freshwater. Out of 2.5% of the freshwater only 1% is easily accessible and rest 96% is saline and ocean based. It becomes necessary to make saline water or sea water fit for use in drinking and as well as agricultural purpose. Surat population is likely to reach 80 lacs in 2025 from 45 lacs (2011). Due to this increase in population Surat city will need more water. Thus it is necessary to treat saline water. Desalination is the process that removes salts and other minerals from the saline water i.e., sea water and brackish water by various methods. The major benefit of desalination is that it can continue to deliver high quality of drinking water even if there is no rain. There are mainly two methods of desalination technologies around the world mainly membrane desalination and thermal desalination. Our study deals with membrane technology. Membrane technology appears to be cheaper as it has low energy consumption varying from 1.5 to 2 kw/m³ and higher recovery ratio. Our proposal deals with providing water for up to 10% of future population of Surat city at optimum cost. This proposal also includes preliminary design of desalination plant and as well as its components.

Key Words: Desalination, Water treatment plant, Water scarcity, Membrane technology, Sea water, Reverse osmosis

1. INTRODUCTION

Water scarcity which occurs not only in arid regions may be characterized as a mismatch between water supply and water demand. Pollution and exploitation of ground water aquifers and surface water have led to decrease of quantity and quality of available natural resources in many regions all around the world. India accounts for about 4% of the world's water resources. Total water available from the precipitation in the country is about 4000 cubic km and total utilizable water resources in the country are 1122 cubic km only. In our country there are about 10360 rivers having mean annual flow in all the river basin is estimated to be 1869 cubic km. Due to ongoing growth of population, industries and agriculture further increases water demand. In addition higher living standard of people result in higher per capita water consumption and hence in nearby future India will face serious water crisis, as per niti ayog report.

1.1 General

Taps in Shimla went dry this summer, posing an unprecedented water crisis in the hill town. Development and overpopulation has created lot of stress on natural

resources in states like Maharashtra, Rajasthan and Gujarat. Thus, an alternative source is essential to provide a solution to the water crisis and however desalination may represent a major solution when facing the future water scarcity problem. Desalination is a special treatment process used for treating sea water which contains on average a salinity of approximately 3.5%, or 35 parts per thousand. Brackish water typically contains TDS in concentrations ranging from 1000 milligrams per litre (mg/l) to 10000 mg/l. Saline water has more than 10000 mg/l TDS. And, brine is very salty water with TDS greater than 35000 mg/l which is not in the permissible limit of domestic water that is 500 TDS. Removes salt and make water fit for use. According to the international desalination association in June 2015 18,426 desalination plant operated worldwide providing water for 300 million people per day which also includes many developed countries like Israel, united states of America, Saudi Arabia, Spain etc. In India largest desalination plant is in Chennai in Minjur which produce 36.5 million cubic meter of water per year.

1.2 Types of Desalination Methods

Desalination technologies can be classified according to the process involved for example: Freeze separation and hydrate separation. (Thermal desalination), Utilizing membranes. (Membrane desalination), Ion exchange and solvent extraction.

The proper choice of a desalination technology will depend on the feed water quality, which is mainly characterized by its total dissolved solids content (TDS value). Reverse osmosis is the dominant desalination option. In seawater desalination as well as in brackish water desalination, reverse osmosis makes up about three quarter of total desalination capacity. In seawater desalination, one quarter of total production is processed by thermal desalination technologies such as multi-stage flash distillation and multi-effect evaporators. In the smaller market of brackish water, membrane based desalination technology is even more prevalent. Energy consumption of reverse osmosis is the lowest among all options for seawater desalination, making it most cost efficient in regions with high energy cost. Especially in brackish water desalination, reverse osmosis offers great advantages over thermal desalination technologies due to its much lower energy consumption at low salt concentration. The variable cost of thermal desalination plants is almost independent of feed water salinity, while membrane process variable cost is nearly proportional to the feed-water salinity and therefore lowers

in brackish water than in seawater desalination, making reverse osmosis and electro dialysis the most economic processes.

1.3 Need for the study

Nearly 600 million Indians faced high to extreme water stress. About 200,000 people died every year due to inadequate access to safe water. 52% of India's agricultural area remains dependent on rainfall so the future expansion of irrigation needs to be focused on last mile efficiency. Twenty-one cities, including Delhi, Bengaluru, Chennai and Hyderabad will run out of groundwater by 2020, affecting 100 million people. Critical groundwater resources, which accounted for 40% of India's water supply, are being depleted at "unsustainable" rates and up to 70% of India's water supply is "contaminated". If the present situation continues, there will be a 6% loss in the country's GDP by 2050. The combination of rapidly declining groundwater levels and limited policy action is likely to be a significant food security risk for the country.

2. STUDY AREA

Surat is a city in the Indian state of Gujarat. It used to be a large seaport and is now a centre for diamond cutting and polishing. It is the eighth largest city and ninth largest urban agglomeration in India. The area of Surat is 4326.97 sq.km out of which 326.5 sq.km is the area of city.

Surat was the world's 4th-fastest growing city in 2016 according to a study conducted by the City Mayors Foundation. The city registered an annualised GDP growth rate of 11.5% over the seven fiscal years between 2001 and 2008. Surat is selected as the first smart IT city in India which is being constituted by the Microsoft City Next Initiative tied up with IT services majors Tata Consultancy Services and Wipro. Surat was selected in 2015 for an IBM Smarter Cities Challenge grant. Surat has been selected as one of twenty Indian cities to be developed as a smart city under PM Narendra Modi's flagship Smart Cities Mission.

Surat has a tropical savanna climate, moderated strongly by the Sea to the Gulf of Cambay. The summer begins in early March and lasts until June. April and May are the hottest months, the average maximum temperature being 37 °C (99 °F). Monsoon begins in late June and the city receives about 1,200 millimeters (47 in) of rain by the end of September, with the average maximum being 32 °C (90 °F) during those months. October and November see the retreat of the monsoon and a return of high temperatures until late November. Winter starts in December and ends in late February, with average mean temperatures of around 23 °C (73 °F), and negligible rain.

Since the 20th century, Surat has experienced some 20 floods. In 1968, most parts of the city were flooded and in 1994 a flood caused a country-wide plague outbreak, Surat

being the epicenter. In 1998, 30 per cent of Surat had gone under water due to flooding in Tapti river following release of water from Ukai dam located 90 km from Surat and in Aug, 2006 more than 95 per cent of the city was under Tapti river waters, killing more than 120 people, stranding tens of thousands in their homes without food or electricity and closing businesses and schools for week.

2.1 Water Availability in Surat

Surat water demand mainly depends on Tapi River and groundwater. As per article of Indian express dated 8 Feb 2018, with lesser rainfall during the last monsoon, the water in Ukai dam did not rise to its maximum level, prompting Surat irrigation department Superintendent Engineer S R Mahakal to send out a letter to the SMC, five municipalities of Ankleshwar, Sachin, two in Navsari and Valsad, and industries using water of Ukai dam, appealing them to save water and not waste it due to the shortage of water in the dam. Mahakal said, "As the summer is around the corner and seeing the quantity of water available in the dam, it is difficult to meet the requirement, as a result of which we have appealed to all the beneficiaries to save the water and make some alternate arrangements."

2.2 Surat Population Scenario

At the time of the next census, the population was almost 3 million. Today, the population has jumped to over 4.5 million. The population density of the city is 1376 persons per square kilometer. It is relied upon to be the most packed city of Gujarat in the accompanying one decade. While it recorded a population growth rate of 65% in 2001 and 2011. Surat Municipal Corporation estimates that its population is inclined to grow at a rate of over 60% and by the year 2023 the city will comprise of 8 million individuals living in the city. SMC experts say that since its development rate is over 60%, it will grow faster when contrasted with Ahmedabad. Surat saw a population growth rate of around 60 and 80% in the midst of the latest three decades. It is probably going to maintain the relentless financial improvement in and around the city.

Thus with increase in population water demand will likely increase and water scarcity will occur, the increase in population and increase in water demand in a particular year is shown graphically in Ch. 4 data collection and hence with the help of desalination our aim is to provide an alternative source of clean drinking water for at least 30% of total population Surat city.

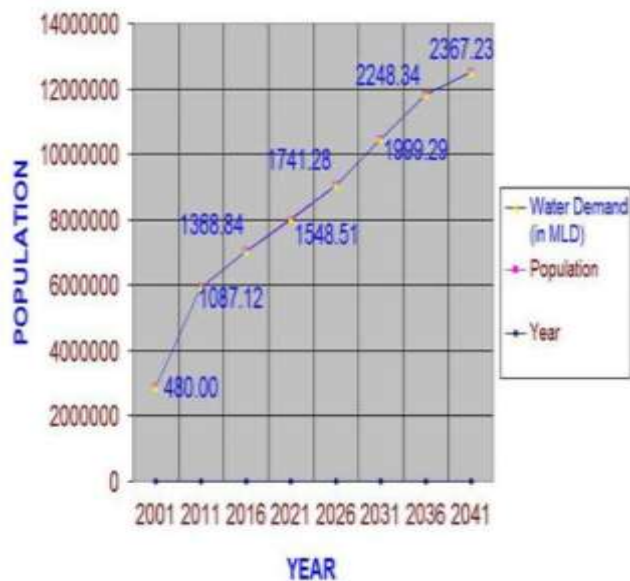

Chart -1: Increase in Population versus Water Demand

3. METHODOLOGY

3.1 Reverse Osmosis

There are two types of membrane process used for desalination: reverse osmosis (RO) and electro dialysis (ED). In the RO process, water from a pressurized saline solution is separated from the dissolved salts by flowing through a water-permeable membrane. The permeate (the liquid flowing through the membrane) is encouraged to flow through the membrane by the pressure differential created between the pressurized feed water and the product water, which is at near-atmospheric pressure. The remaining feed water continues through the pressurized side of the reactor as brine. No heating or phase change takes place. The major energy requirement is for the initial pressurization of the feed water.

In practice, the feed water is pumped into a closed container, against the membrane, to pressurize it. As the product water passes through the membrane, the remaining feed water and brine solution becomes more and more concentrated. To reduce the concentration of dissolved salts remaining, a portion of this concentrated feed water-brine solution is withdrawn from the container. Without this discharge, the concentration of dissolved salts in the feed water would continue to increase, requiring ever-increasing energy inputs to overcome the naturally increased osmotic pressure.

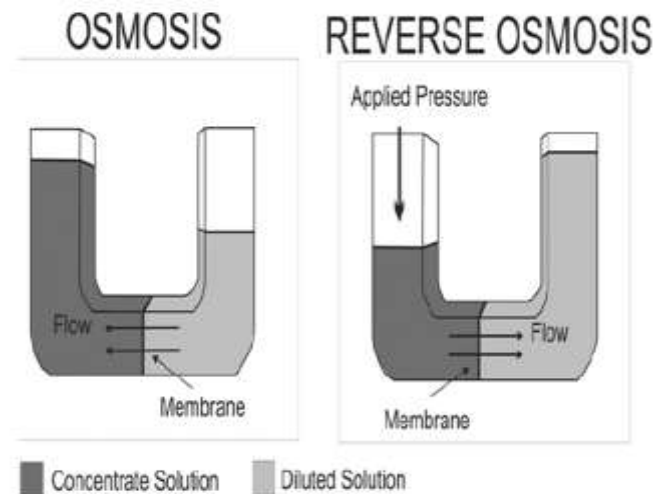

Fig -1: Difference between osmosis and Reverse osmosis

Osmosis occurs when a semi-permeable membrane (permeable to water and not to the solute) separates two aqueous solutions of different concentration. At equal pressure and temperature on both sides of the membrane, water will diffuse (“permeate”) through the membrane resulting in a net flow from the dilute to the more concentrated solution until the concentrations on both sides of the membrane become equal. This process will also take place if the pressures on both sides are different, as long as the pressure difference Δp between the concentrated side and the dilute side is not larger than a certain value that depends upon the difference of the respective concentrations and is called the osmotic pressure difference $\Delta \Pi$. If the differential pressure Δp is larger than $\Delta \Pi$, the direction of flow is reversed and water flows from the concentrate to the dilute side. This process is called Reverse Osmosis.

3.2 Process of Desalination

The process includes the following stages:

Water abstraction:- The feed water can be realised either through coast- and beach wells or through open seawater intake systems. Coast- and beach wells provide better quality water with less turbidity, algae and total dissolved solids than open seawater intakes, but require more space. However open seawater system requires less pumping operation.

Pre-treatment:- Pre-treatment includes all activities to adjust the intake water in constitution and pH-value. Particulate matter is removed from the feed-water and chemicals are added to prevent scaling and fouling. Good pre-treatment is of measure importance for successful operation of reverse osmosis plant.

Pumping system:- The pumping system is required to overcome height differences within the distribution chain and to apply the necessary pressure to the feed.

Membrane separation units:- The membrane is capable of separating salt from water with a rejection of 98–99.5%, depending on the membranes in use.

Energy recovery:- The energy recovery system is responsible for the transfer of potential energy from the concentrate to the feed. Current energy recovery systems such as work exchangers operate with efficiencies of up to 96%.

Post-treatment:- In post-treatment permeate is remineralised, re-hardened, disinfected by chlorination and adjusted to drinking water standards.

Control system:- A control system maintains a continuous and reliable production. Fig. shows a simplified reverse osmosis scheme with energy recovery system and open seawater intake.

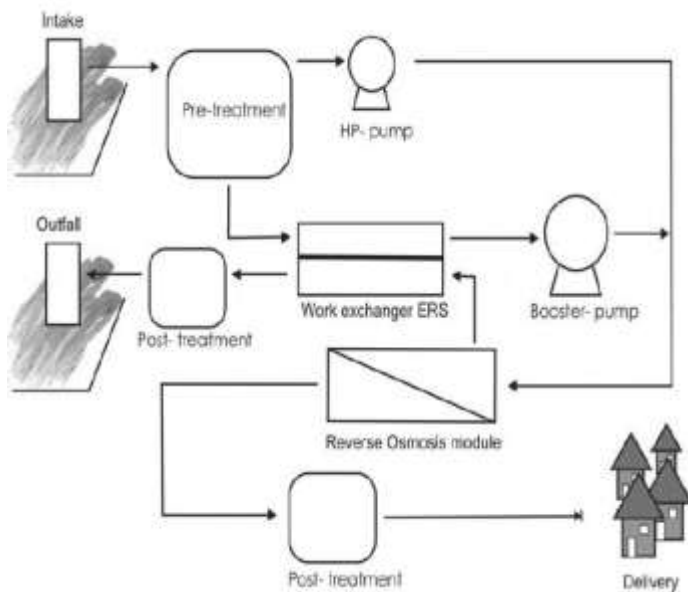

Fig -2: Reverse Osmosis process

3.3 Membrane

Membrane can be defined as essentially as a barrier; which separates two phases and restrict transport of various chemicals in a selective manner. Membrane is a heart of every membrane process. The membrane can be made of inorganic or organic, synthetic or biological product. Membranes of reverse osmosis system are permeable for solvent and impermeable for solute.

There are four types of module related to the type of membrane, Spiral wound, Tubular, Plate and frame, Hollow module membrane.

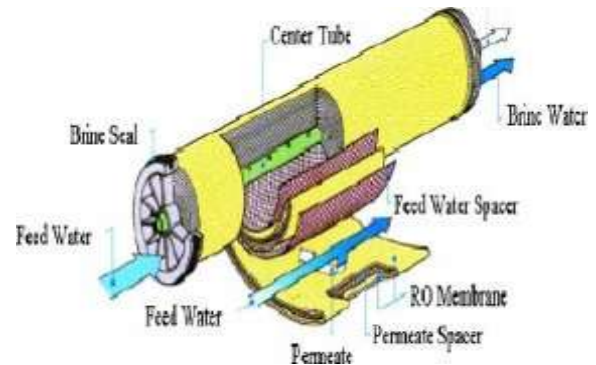

Fig -3: Spiral wound module

Materials used for membranes are Cellulose acetate, Aromatic polyamide, Polyamide, Polyphenylene oxides, Sulfonated polysulfone composite, Graphene membranes.

4. PRELIMINARY DESIGN OF COMPONENTS OF DESALINATION PLANT

Design of Intake Chamber

Provide 2 nos. of submerged HDPE pipe intake of diameter 2000 mm having velocity limited to 5 m/sec.

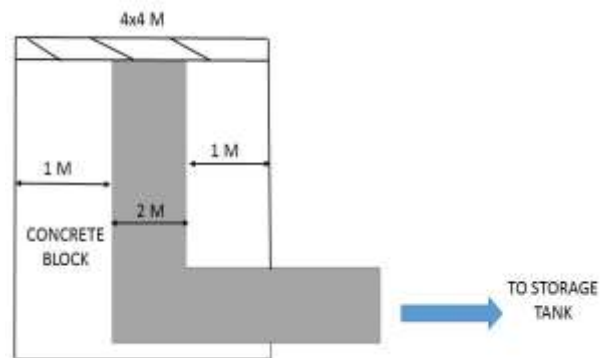

Fig - 4: Intake chamber

Design of Storage pond

$b_1 = 100$ m, $b_2 = 108$ m, $h = 8$ m, $h_1 = 7.5$ m), $L = 220$ m, Volume = 171187.5 m³, 171 MLD * 3 (Nos) = 513 MLD

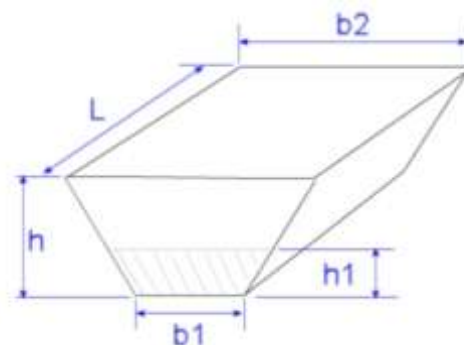

Fig - 5: Storage tank

Design of Stilling chamber

Provide 8m * 8m * 3m

Design of Mechanical rapid mixing unit

Providing 6 blades, area of each blade = $(1/6) * 1.88 = 0.313$ m² Provide blades of size 0.9m * 0.6m.

Design of Parshall flume

$Q_{max} = 500$ MLD, $W = 900$, $A = 1650$, $B = 1619$, $C = 1200$, $C_1 = 1547$, $F = 600$, $G = 900$, $K = 75$, $N = 225$

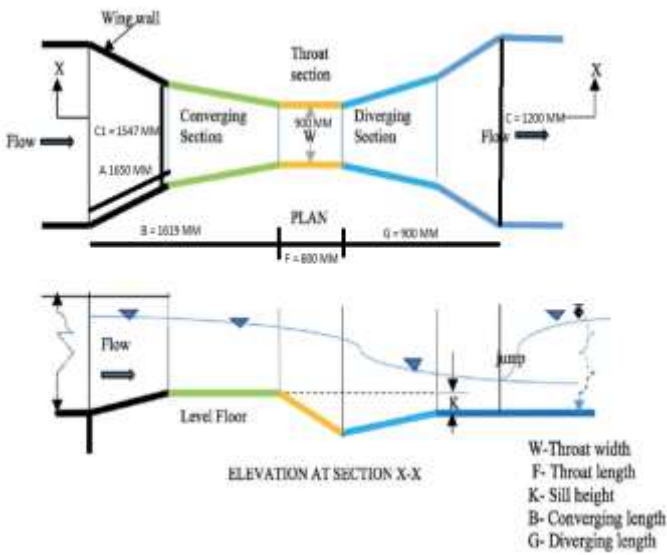

Fig - 6: Parshall Flume

Design of Flocculator

Length * Width = 8.2m * 24m

Provide 3 Nos. of Paddles for mixing

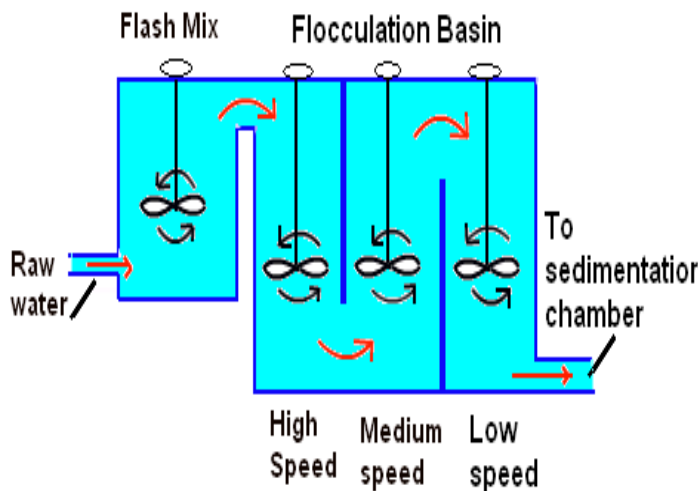

Fig - 7: Flocculator

Design of Lamella clarifier

Length * Width * Height

= 10 m * 3.5 m * 2.5m

Provide 6 Nos. + 2 Stand by = 8 Nos

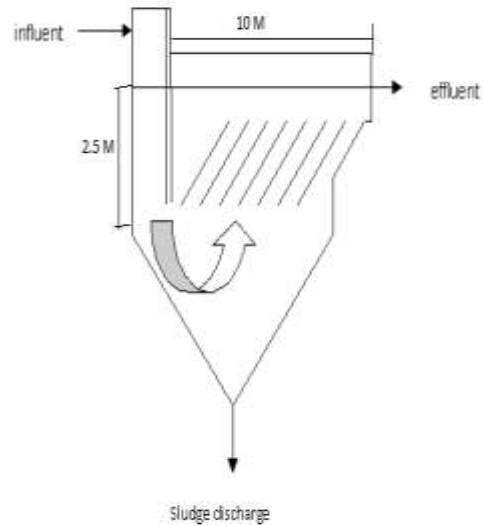

Fig - 8: Lamella clarifier

Design of Rapid gravity sand filter

Size: 10 m * 8 m

Provide Nos. + 4 Nos. for standby.

Total = 48 Nos.

Design of wash water troughs

4 nos. wash water troughs of size 46 cm * 51 cm

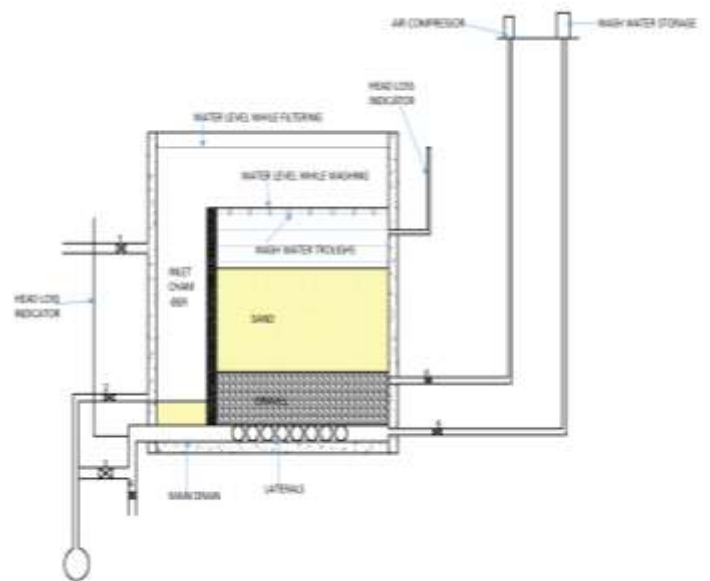

Fig - 9: Rapid gravity sand filter

Design of Pressure sand filter

Provide 10 Nos. of 6m dia. & 1.5m height

Design of Membranes

Provide vessel of 1.276 m * 2.25 m * 1.20 m

Total Nos. of member = 6667 * 1.20 = 8000 Nos. of membrane.

5. REQUIRED AREA CALACULATION

Unit	Calculation	Area (m ²)
Pond	(108 * 220) * 4	95040
Walkway	(4 * 220) * 2	1760
Walkway	(4 * 108) * 2	864
Pump house	(3 * 6) * 2	36
Chemical unit	(5 * 10) * 1	50
Stilling basin	(4 * 4) * 1	16
Parshall Flume	(1.75 * 4) * 1	7
Rapid Mixing	(3.6 * 3.6) * 1	12.96
Flocculator	(12.1 * 4.1) * 1	49.61
Lamella clarifier	(40 * 3.5) * 2	280
Rapid sand filter	(105 * 21) * 2	4410
Walkway	(3 * 105) * 1	315
Pressure filter	($\pi/4$) * 6 ²	282.74
Reverse osmosis	(115 * 30)	3450
Sludge pit	(2 * 2)	4
Sludge thickener	($\pi/4$) * 2 ²	3.14
Collection sump	(1.5 * 1.5) + (1 * 1)	3.25
Sludge disposal	(10 * 10)	100
Storage tank	(180 * 270)	48600
Salt generation	740	740
	Total	156063.7

Provide 20% for road = (156063.7 * 1.20) = 187276.44 m²

Add another 10% for green area = (187276.44 * 1.10) = 206004.084 m²

206004.084 m² = 20.60 hectare \approx 22 hectare

6. CONCLUSIONS

6.1 Providing Drinking water at optimum cost by treating sea water

The population of Surat city will likely to increase at a rate of 2.7%. Thus, the water demand which is now estimated as 1200MLD and more & more water will require meeting the demand which will increase up to 1999.29MLD in 2031 and water scarcity will likely to occur. However, if the desalination method is provided around the city which will serve as an important source of useable water without any

effect to the ecological system and can also provide water to the drought affected region.

There are number of methods available for desalination but reverse osmosis presents a viable option as RO has less energy consumption rate i.e.; 2kw/m³ and higher recovery ratio therefore, it can be called as a solution of centuries for water crisis.

6.2 Salt generation and development of salt industries and exporting salt

As India is the third largest salt producing country in the world after China and USA with global annual production being about 230 million tonnes out of which 59 lakhs tonnes is supplied for human consumption and 107 lakhs tonnes is supplied to industry. However India also exports 35 lakhs tonnes on an average to major countries such as Japan, Bangladesh, Indonesia, South Korea, Malaysia, UAE, Vietnam, Qatar, etc. Salt can be generated from brine which will also yield revenue to the desalination plant.

ACKNOWLEDGEMENT

I would like to give special thanks to my friend who equally worked as I did for this study, Lala Abdullah, Desai Maulik, Golakiya Manthan, and Nirban Nadeem.

REFERENCES

- [1] Lauren F. Greenlee, Desmond F. Freeman, Benoit Marrot, Philippe Moulin Reverse osmosis desalination: Water sources, technology, and today's challenges Water research 43 (2009) 2317-2348
- [2] T. J. Welgemoed, C. F. Schutte Capacitive Deionization Technology: An alternative desalination solution Desalination 183 (2005) 327-340
- [3] Akili D. Khawajia, Ibrahim K. Kutubkhanaha, Jong-Mihn Wieb Advances in seawater desalination technologies Desalination 221 (2008) 47-69
- [4] Ghaffour, NorEddine; Missimer, Thomas M.; Amy, Gary L. Technical review and evaluation of the economics of water desalination: Current and future challenges for better water supply sustainability. Desalination
- [5] Sabine Lattemann, Thomas Höpner Environmental impact and impact assessment of seawater desalination. Desalination 220 (2008) 1-15
- [6] F. Silva Pinto, R. Cunha Marques Desalination projects economic feasibility: A standardization of cost determinants. Renewable and Sustainable Energy Reviews 78 (2017) 904-915
- [7] C. Fritzman, J. Lowerberg, t. Wintgens, T. Melin: State of art of reverse osmosis desalination, Desalination 216 (2007) 1-76

- [8] W. F. J. M. Nooijen and J.W. Woutters: Optimizing and planning of sea water desalination, Desalination 89 (1992)1 – 20
- [9] Chris Mooij: Hama water desalination plant: planning and finding, Desalination 203 (2007) 107 – 118
- [10] Government of Gujarat Development of Desalination Plant at Bhavnagar / Mundra

Books

- [11] Desalination Engineering Planning and Design by Nikolay Voutchkov.
- [12] Environmental Engineering (Volume 1) Water Supply Engineering by S.K.Garg.
- [13] Water Supply Engineering by B.C.Punamia.
- [14] Water and Waste Water Engineering by Mackenzie L. Davis.
- [15] Wastewater Engineering by Metcalf Eddy.
- [16] Water Supply & Sanitary Engineering by G.S.Birdie and J.S.Birdie.