

PASSWORD BASED CIRCUIT BREAKER USING DTMF

Mithilesh Padhen¹, Prof P.V. Sontakke²

¹Student, Dept. of Electronics and Telecommunication Engineering, Pimpri Chinchwad College of Engineering, Pune, Maharashtra, India

²Professor, Dept. of Electronics and Telecommunication Engineering, Pimpri Chinchwad College of Engineering, Pune, Maharashtra, India

Abstract - Today, in the age of technology and high-end machines working on a live electric line is now considered significantly safer than in years past. The rapid and structured growth of the electrical industry has developed effective standards and established safety procedures to minimize various types of major hazards that led to severe injuries and death of the operators. However, if the scenario of the line needs to repair that's where the job will be. Understanding various potential dangers of working with very high-voltage equipment is mandatory before going up on any electrical pole or high voltage devices. Given the tremendous challenges and opportunities, the job entails, understanding and learning what could go wrong in the process of implementing is the optimized and safe way to ensure an accident doesn't occur in the case of electrical circuits. So, in this project, a password-based circuit breaker is designed which is an operated electrical switch which designed to protect an electrical circuit from damage or breakdown caused by excess current from an overload or short circuit, or any other failure. The project having primary function is to interrupt the current flow after a fault is detected. Considering the case of fuse, which generally operates once and then it has to be replaced, but a circuit breaker can be reset either manually or automatically according to the working conditions present to resume normal and smooth operation.

- To test a circuit using breadboard and troubleshoot the same and to generate the report based on the overall system.

1.2 Problem Statement

This password-based circuit breaker system using DTMF should provide a solution which ensures the safety of the system of the maintenance staff and provide security.

2. METHODOLOGY

2.1 Block Diagram

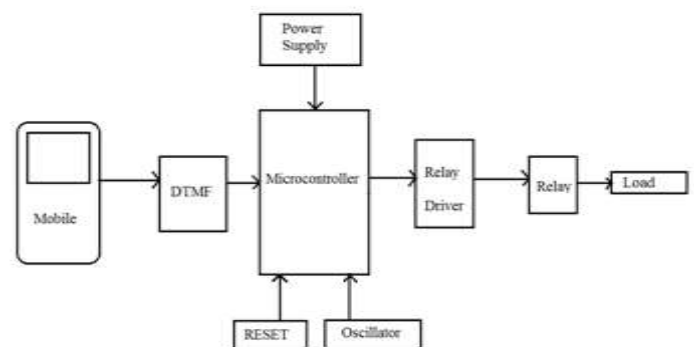

Fig-1: Block diagram

Key Words: Live Electric line, High-voltage equipment, Circuit breaker, Current flow, Fuse etc.

1. INTRODUCTION

The Power system fault is an unwanted condition occurring in the power system. These types of conditions are short circuit, current leakage, ground short, over current and over voltage. The methodology used here is the application of the mobile technology with the electrical circuit. Also, it involves integration of DTMF module with circuit and loads for generating output response of the system, which will eventually produce a very efficient and reliable result.

1.1 Objectives

- To study and simulate the circuit using different simulation software.
- To interface different components to the microcontroller.
- To study the PCB design including coating, etching, drilling etc.
- To mount the component with proper soldering.

Here the mobile phones are used as the inputs for the systems and the DTMF module decodes the signal and give the output to the microcontroller. Then controller provides input to the relay driver and then relays will work at last the load will be ON or OFF.

2.2 Working Principle

DTMF encoder which is generally present in mobiles, and the decoder circuit is present in the microcontroller. The mobile is connected at one end of the circuit with the help of the phone jack. The mobile jack has a presence of two wires. The red wire is connected to the decoder IC and the black one is grounded.

Whenever the user tries to make a call to the number in phone, then automatically the call goes into auto answer mode and the frequency of the signal corresponds to key pressed on the phone keypad send by the user is decoded by

the module of DTMF decoder resulting this decoded signal acts like a strobe signal to the microcontroller.

So, the microcontroller senses the strobe signal, and then the function which is corresponding to the obtained decoded value will be performed by the microcontroller according to predefined program code written in the controller. Resulting the corresponding load will be turned ON/OFF by of the relay connected between the controllers and the load.

3. SPECIFICATIONS

3.1 PIC MICROCONTROLLER

Performance	10 MIPS up to 3 Volt
Architecture	Optimized RISC
Internal Oscillator	31 KHz to 8 MHz with 4xPLL
Voltage Range	2.0 to 5.5 Volts
Modes	Run, Idle and Sleep
ADC System	10-bit ADC, 13 Channels
Voltage Detection and Reset	Programmable low voltage detection and reset module
Comparators	Two analog comparators with multiplexing peripherals
Serial Ports	Master synchronous serial port with SPI and I2C mode
Timers	4 Timer having capacity up to 5 PWM outputs

3.2 DTMF

Dual-tone multi-frequency signalling (DTMF) is an identity related to the telecommunication engineering in which the concepts of the signaling system used. Now, in case of the signaling system the voice-frequency band which is present over the telephone lines between telephones system and other communications devices present and switching centers. So, the DTMF type of system uses a set of various eight audio frequencies which is generally transmitted in pairs to represent 16 different signals, represented by the ten digits, including letters and symbols A to D, and # and *. As the signals become in the voice frequency range, they can be transmitted through electrical circuits such as repeaters and amplifiers, and over radio communication and microwave links, thus eliminating and eradicating the need for various intermediate operators present on long-distance circuits.

3.3 Relay

Relay is an electromagnetic switch which used to control the electrical device. Copper core magnetic fluxes play the main role here. The relay's switch connections are labelled COM, NC and NO.

COM = Common, it is the moving part of the itch.

NC = Normally Closed, when the relay coil is off then the COM is connected to the NC.

NO = Normally Open, when the relay coil is on then the COM is connected to the NO.

3.3 Relay Driver

A Relay driver IC is an electro-magnetic switch that will be used whenever we want to use a low voltage circuit to switch a light bulb ON and OFF which is connected to 220V mains supply. The required current which is used to drive the relay coil is more than what can be supplied by various integrated circuits like Op-Amp, etc. Relays have various unique switching properties and they are replaced with the solid-state switches that are stronger than solid-state devices.

Resulting ULN2003A is used as a relay driver. The ULN2003A is the monolithic type of high-voltage, high-current devices having Darlington transistor arrays. Each driver consists of seven n-p-n Darlington pairs that are having features of very high-voltage outputs with common-cathode clamp diodes for switching the inductive loads. Generally, the collector current rating of a single Darlington pair is 500 mA, these Darlington pairs may be paralleled for higher current capability if required.

4. SOFTWARE ARCHITECTURE

4.1 Flowchart

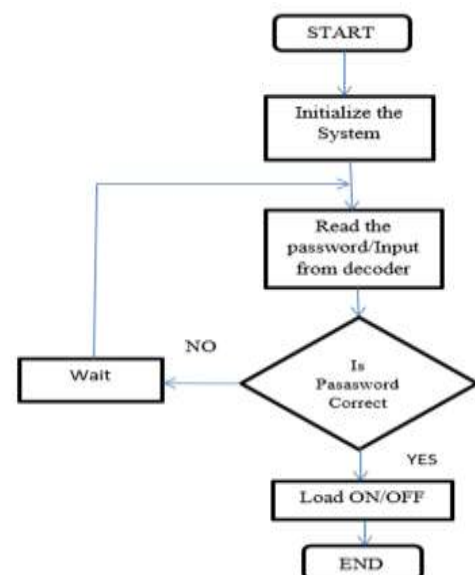

Fig-2: Flowchart

4.2 Algorithm

- Get the inputs using the mobile phones
- Convert inputs into the decode signal with the help of DTMF decoder
- Communication between the DTMF decoder and the microcontroller
- Microcontroller checking the inputs with the predefined passwords
- Coordination between controller and the relay driver
- Relay driver driving the present relays
- Connected load gets turned ON or OFF

4.3 Simulation of Circuit

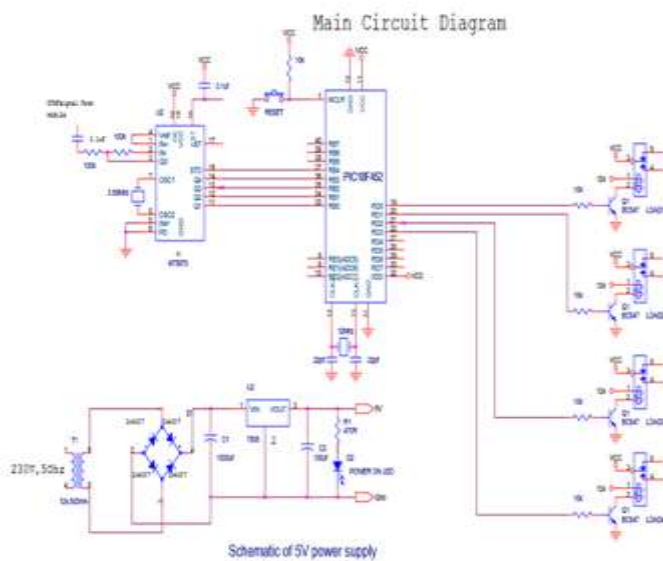

Fig-3: Simulation of Circuit

The simulation tool used is Proteus Design Suite. The Proteus Design Suite is a Windows application for schematic capture, simulation, and PCB layout design. It can be used in many configurations, depending on the size of designs being produced and the requirements for microcontroller simulation.

4.4 PCB Design Layout

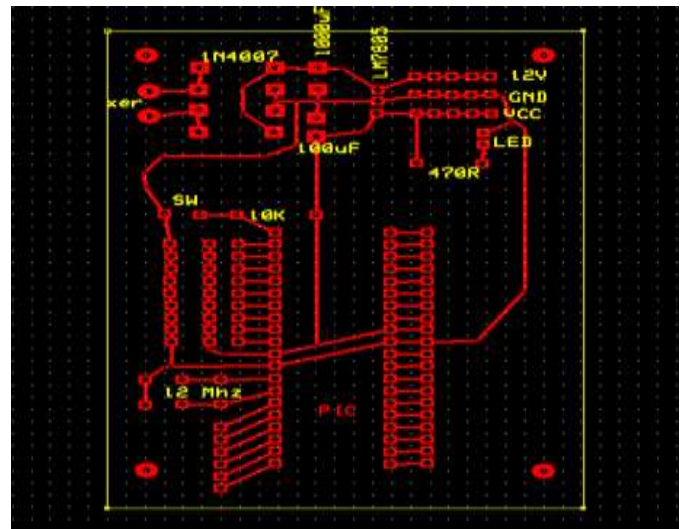

Fig-4: PCB Design Layout

The tool used for PCB designing is ExpressPCB. The PCB Layout module is automatically given connectivity information in the form of a netlist from the schematic capture module. It applies this information, together with the user-specified design rules and various design automation tools, to assist with error-free board design.

5. HARDWARE ARCHITECTURE

5.1 Mechanical Setup

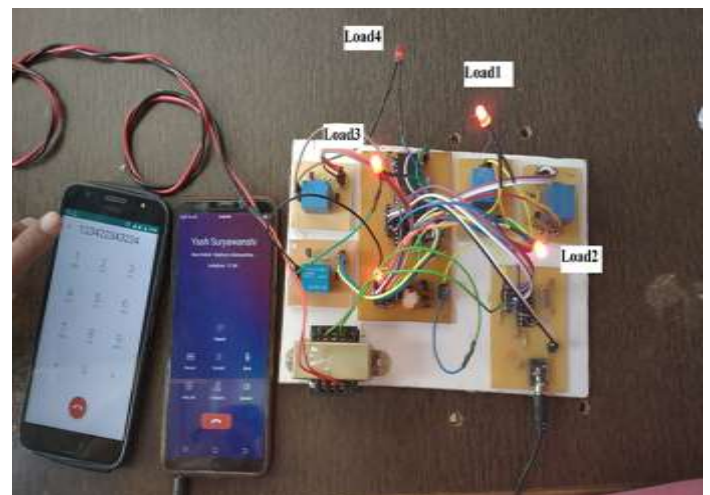

Fig-5: Mechanical Setup

5.2 Details

Here the call from one phone is dialed to another one and that call is received in auto-answer mode so the connections are established. Now in this case for turning ON the load 1, load 2, load 3, load 4 the password is set as 1234, 2234, 3234, 4234. As shown above the passwords 1234, 2234,

3234 are used for turning ON the load 1, load 2, load 3. The same passwords can be used for turning OFF the load 1, load 2, load 3.

6. CONCLUSION

The developed control method uses the various commercial mobile communication networks as the path of data transmission resulting providing higher reliability, efficiency and optimization to the user to who controls the system continuously by sending the mobile phone keywords as inputs to the module of DTMF. Also, the system works on a single given known password. No other person can re-close the breaker once the password is given into the system other than the person who has given it. It is an effective method for providing safety to working staff, and there is no scope of the password stealing.

FUTURE SCOPE

Future work includes research on the robot control system mobile communication networks. This will facilitate controlling the remote robot, using the DTMF of mobile phone with video data from the remote mobile robot's camera. In this project, implementation is done only for 4 loads. Integration of many loads each with a unique ID can be done. Automatic fault detector circuit can be used along with this system with the help of feedback mechanism.

ACKNOWLEDGMENTS

I am grateful to my project guide Prof. P. V. Sontakke for the immense support and keen interest shown in the project. We also acknowledge our overwhelming gratitude and immense respect to Dr. A. M. Fulambarkar, Principal of Pimpri Chinchwad College of Engineering and Dr. N. B. Chopade, Head of Department of Electronics and Telecommunications who inspired me a lot to achieve the goal and I came to learn about so many new things.

REFERENCES

[1] Lalitha urs B.R., Meghna K.S, Mouna Machamma P.M, Sumitha Suresh, Ashwini K.R, "Switching Operation of Circuit Breakers Using Password", 2018 IJSRCSEIT | Volume 4 | Issue 6 | ISSN: 2456-3307

[2] Ratnesh Kumar, "DESIGN AND IMPLEMENTATION OF CELL PHONE OPREATED METAL DETECTOR", International Journal of Research in Engineering, Technology and Science, Volume VI, Special Issue, July 2016, ISSN 2454-1915

[3] Kumar, R., & Khalkho, A. N. (2016). "Design and the implementation of metal detector using DTMF technology". 2016 International Conference on Signal Processing, Communication, Power and Embedded System (SCOPEs). doi:10.1109/scopes.2016.7955853

[4] Mrs. S. Kalpana, Mrs. Ch. Jayalakshmi "Password Based Circuit Breaker Using DTMF For Electric Line Man Safety", International Journal of Scientific Development and Research (IJS DR) July 2016 IJS DR, Volume 1, Issue 7 ISSN: 2455-2631

[5] P. Shrivastava, A. Gupta, A. Singh and A. Srivastava, "DTMF based security Robot-SECBOT an ease for un-manned security,"2014 International Conference on High Performance Computing and Applications (ICHPCA), Bhubaneswar 2014, pp. 15 doi: 10.1109 / ICHPCA.2014.7045366

[6] Rngkuti, H. A., & Simatupang, J. W. (2015). "Security lock with DTMF polyphonic tone sensor". 2015 International Conference on Automation, Cognitive Science, Optics, Micro-Electro-Mechanical System, and Information Technology (ICACOMIT). doi:10.1109/icacomit.2015.7440188