

DYNAMIC ANALYSIS ON VIBRATION GRADER

Mohd Zaheer Ali¹, Dr. P. Shailesh², M.Prasad³

¹P.G Student, Dept of Mechanical Engineering, Methodist College of Engineering and Technology, Telangana, India

²Professor, Dept of Mechanical Engineering, Methodist College of Engineering and Technology, Telangana, India

³Asst Professor, Dept of Mechanical Engineering, Methodist College of Engineering and Technology, Telangana, India

Abstract - Vibration screen separator (classifier) with attached aspiration channel is designed for cleaning and pre-cleaning of all agricultural crops from impurities and admixtures. It is destined for high capacities and continuous run. The screen separator is fitted with pair of screens, which ensure separation of over and undersize impurities from granular materials. Sieves are cleaned by flexible balls. High frequency vibrations are generated by a pair of electric vibrators which results in high quality cleaning at large capacities. Different screens are used for different materials. The vibration grader runs 8hrs per shift a day at high frequency vibrations and it is necessary to run regularly, so the machine should with stand to the vibrations generated. But due to high frequency vibrations the life of the machine is reduced and replacement of parts will be done frequently. To reduce this vibration and to increase machine life design optimization will be done by employing finite element analysis. The objective of this project is to make a 3D model of the existing vibration grader and study the dynamic behavior of the grader by performing the finite element analysis. After determining the root cause of the failure of the existing vibration grader through finite element analysis, an alternative design was proposed, which will be resonant free and also meet the design requirement. Modal and harmonic analysis was performed to understand and optimize the dynamic behavior of the vibration grader. NX-CAD software is used for 3D modeling and ANSYS software is used to do finite element analysis.

Key Words: High frequency vibrations, Dynamic behavior, Finite element analysis

1. INTRODUCTION

Vibration graders are used to screen the material to different sizes with the help of the screen the material that are crushed are categorized into various as per the requirement, and then sent to further processes. These are used in ceramic industries and thermal plants to screen the various sizes of the coal that comes to the screen from the crusher. The required size of the coal are filtered to the bottom of the screen and sent to the next processing section and the remaining material is sent again to the crusher.

Operating Principle: It adjusts the vibratory movement by tube-shaped violent vibration screen of eccentric shaft and

eccentric blocks. The body moves linear motion in order to make the materials screened.

Construction of machine: The screen basket is of welded, riveted bolted construction. The vibrator assembly consists of a shaft on which counter weight is provided. This shaft runs into special roller bearing sealed in housing. The spring assembly normally consists of helical spring, or combination of both. Screening decks consists perforated plate grizzly type bar construction. The screen gets this motion from a electric motor through v-belt drive.



Figure -1.1: Vibration grader assembly

Working principle: Motor drives the vibrator through v-belt. Rotation of this vibrator exerted on the screen basket in the vertical plane and this causes the vibrating basket to obtain vibrating motion. The diameter of the circular motion (twice the amplitude) is fixed by the vibrator and unbalanced weight fixed on it and it is dependent on vibrating weight of the machine.. The direction of rotation of the vibrator is marked on the machine with normal free floating material and with normal inclination (15 degree to 18 degree), the direction is forward but, material which are difficult to screen (normally wet materials and when sleep deck inclination 15 degree to 30 degree) is provided the direction of rotation.

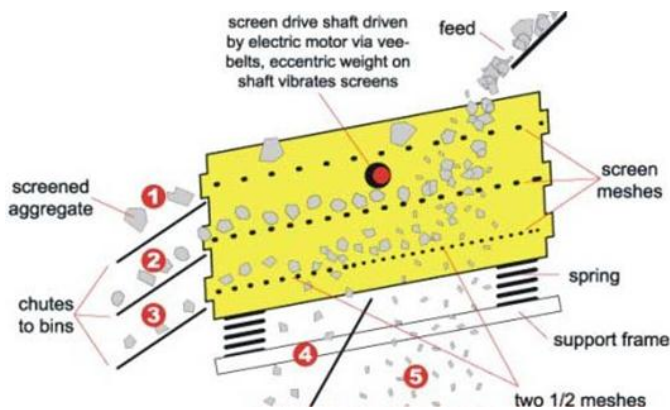

Figure -1.2: Shows the screen

Physical principle

- Vibration - either sinusoidal vibration or gyratory vibration.
- Sinusoidal Vibration occurs at an angled plane relative to the horizontal. The vibration is in a wave form determined by frequency and amplitude.
- Gyratory Vibration occurs at near level plane at low angles in a reciprocating side to side motion.

Gravity - After filtering the material is thrown from the screen causing it to fall to a lower level.

2. PROBLEM DEFINITION

The vibratory grader which was fabricated by a reputed manufacturing company was failing during the testing process. The source of failure was identified as the occurrence of resonance at the lower frequency level. The objective of this project is to identify the critical frequencies and the critical locations where the resonance is taking place. The objective of the project is to study the dynamic behavior of the grader by performing the finite element analysis. After determining the critical frequencies and the critical locations of the existing vibration grader through finite element analysis, an optimized design shall be proposed, which will be resonant free and also meet the design requirement. Modal and harmonic analysis will be performed to understand and optimize the dynamic behavior of the vibration grader. NX-CAD software will be used for 3D modeling and ANSYS software will be used to do finite element analysis.

3. METHODOLOGY

The methodology followed in this project is as follows:

- Create a 3D model of the existing vibratory grader assembly using NX-CAD software, Later, it is converted into parasolid file and import the model into Ansys to do structural analysis.
- Perform static analysis for the operating loads on the existing model of the vibratory grader assembly.

- Perform Modal analysis to find natural frequencies on the existing model of the vibratory grader assembly. From the results, the natural frequencies, mode shapes and their mass participations of the vibratory grader assembly are plotted and checked if any natural frequencies are present in the operating range of the vibratory grader assembly and critical frequencies are identified.
- Harmonic analysis is done on the existing vibratory grader assembly at the critical frequencies obtained from modal analysis and stresses and deflections are documented.
- Based on the above results, design changes are implemented to reduce the stresses and deflections.
- Perform static analysis for the operating loads on the existing model of the modified vibratory grader assembly.
- Perform Modal analysis to find natural frequencies on the modified model of the vibratory grader assembly.
- Perform Harmonic analysis on the modified vibratory grader assembly at the critical frequencies obtained from modal analysis and stresses and deflections are documented.

4. MODELING & ASSEMBLY OF VIBRATION GRADER

The 3d model of vibration is developed using NX-cad software. The Geometrical dimensions required for developing part model of each part in total assembly of vibration grader is done by manufacturing drawings. The Main components in order to complete the assembly of vibration grader are below.

1. Center beam
2. Counter weight (Non-drive)
3. Hallow shaft
4. Main shaft
5. Bearing housing
6. Side plates
7. Side support
8. Spring support
9. V-pulley
10. I-section horizontal support
11. Vibration screen assembly

4.1 Hollow Shaft Assembly

CENTER BEAM: Center Beam acts like a support section for assembly of main shaft to the rotor within attachment of V-Pulley. The manufacturing drawing and part model of center beam can see in figures 4.1.1

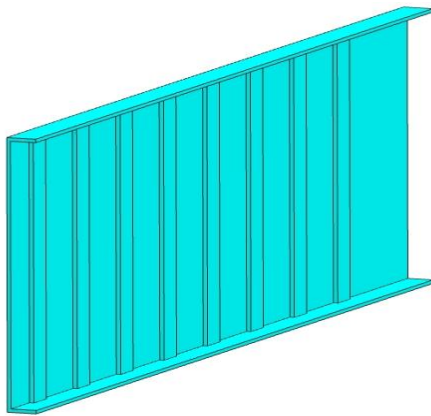

Figure -4.2.6: Shows the 3D model of Vibratory screen side plate

VIBRATORY SCREEN BASE

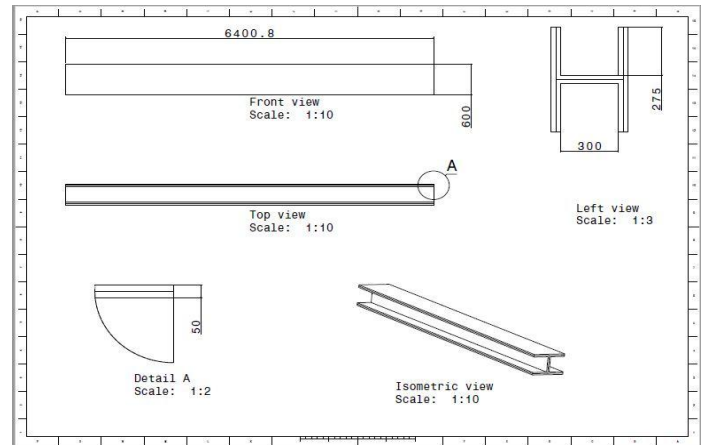

Figure -4.2.9 shows the 2D drawing of Vibratory screen Base

VIBRATORY SCREEN BODY

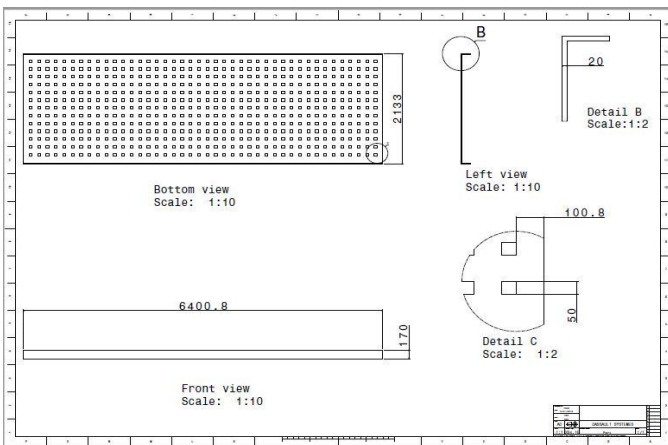

Figure 4.2.7: Shows the manufacturing drawing of Vibratory screen body

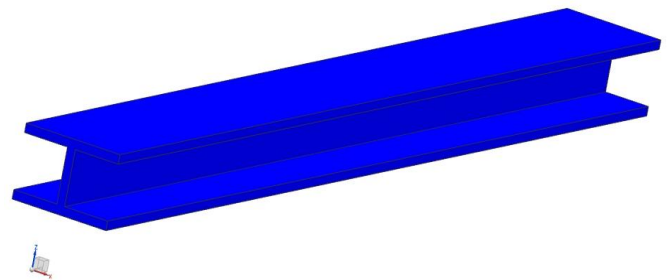

Figure -4.2.10 shows the 3D model of Vibratory screen Base

VIBRATORY SCREEN SUPPORT SPRING

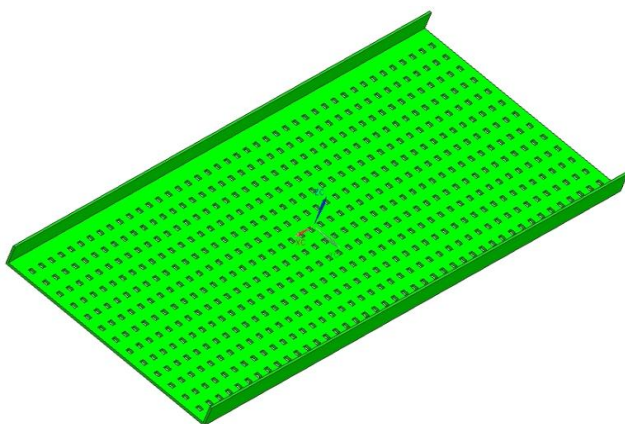

Figure -4.2.8 shows the 3D model of Vibratory screen body

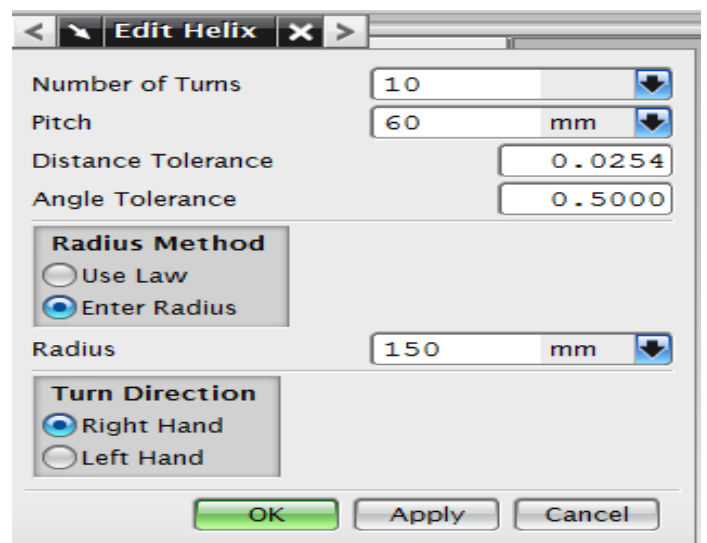

Figure -4.2.11 shows the 2D data of Vibratory screen support spring

ASSEMBLY OF VIBRATION GRADER

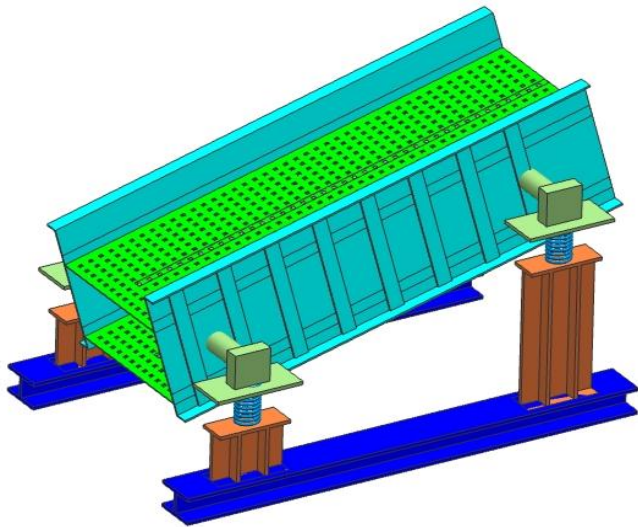

Figure -4.2.12 shows the 3D shell model of Vibratory screen assembly

here we can able to find stresses and strain on object with respect to applied loads and how much deformation we will get on the object

Methods of performing Structural Analysis

To perform an analysis the structural engineer must assign proper information regarding the boundary conditions which is applicable for such kind of problem which includes loads, geometry, supports, and material properties. The results of such analysis include displacements, strains and stresses, support reactions. Then after this analysis may examine the dynamic response, stability of the object

DESCRIPTION:

ANSYS is a Finite Element Analysis (FEA) widely used in the Computer Aided Engineering (CAE) field. ANSYS software allow to generate computer models of structures, machine components or systems, apply operating loads and other design requirements and study physical responses, such as stresses, temperature distributions, pressure, etc. The ANSYS software has a various analysis systems, ranging from automobiles to such highly sophisticated systems as aircraft, nuclear reactor and bridges.

5.2 Finite element modeling

3D model of the vibration grader assembly was developed in UNIGRAPHICS from the design calculations done. The model was then converted into a parasolid to import into ANSYS. A Finite Element model was developed with shell elements. The elements that are used for idealizing the vibration grader assembly were described below. A detailed Finite Element model was built with shell elements to idealize all the components of the vibration grader assembly. Modal analysis was carried out to find the first 10 natural frequencies. Changes were also implemented to shift the fundamental natural frequency.

The elements that are used for idealizing the vibration grader assembly are Shell 63. The description of each element is given below.

MATERIAL PROPERTIES:

All the components of the Vibration grader assembly are made using hot-rolled structural steel IS: 2062-1999, Grade A, Fe 410WA. All the components of the vibration grader assembly are assigned as per the below material properties.

Steel IS: 2062-1999 Mechanical Properties:

- Young's modulus = 200Gpa
- Yield Strength = 410 Mpa
- Tensile Strength = 250 Mpa

5. FINITE ELEMENT ANALYSIS

5.1 Structural analysis on vibration grader

Finite Element Modeling (FEM) and Finite Element Analysis (FEA) are two most popular mechanical engineering applications under CAE (Computer aided engineering). This is attributed to the fact that the FEM is perhaps the most popular numerical technique for solving engineering problems. The method is can handle any complex shape of geometry (problem domain), any material properties, any boundary conditions and any loading conditions. The specialty of the FEM gives the analysis requirements of today's complex engineering systems and designs where closed form solutions are governing equilibrium equations are not available. In addition it is an efficient design tool by which designers can perform parametric design studying various cases (different shapes, material loads etc.) analyzing them and choosing the optimum design.

FINITE ELEMENT METHOD

The FEM is numerical analysis technique for obtaining approximate solutions to wide variety of engineering problems. The method originated in the aerospace industry as a tool to study stresses in complicated structures. To solve problem it sub divides a large object into smaller elements that are known as finite elements. The equations then assembled into large equations that creates the whole problem

Structural Analysis

It is useful to find the behavior of the metals when we apply set of physical loads with respect to boundary conditions

SHELL63 Element Description

No of Nodes: 4

No. of dof: 6 (Ux, Uy, Uz, Rotx, Roty, Rotz)

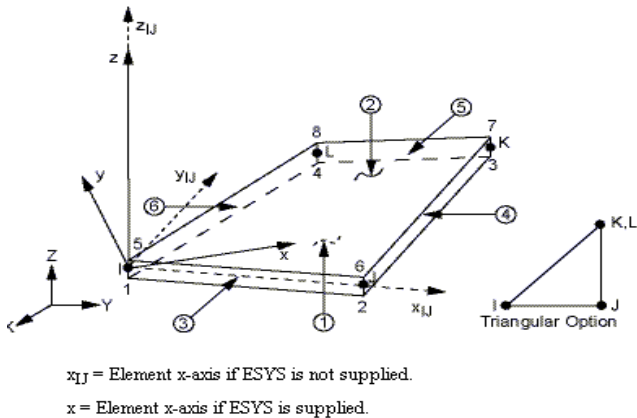

Figure -5.2.1 shows the Shell Element Description

SHELL63 has both bending and membrane capabilities. Both in-plane and normal loads are permitted. The element has six degrees of freedom at each node: translations & rotations in the nodal x, y, and z directions.

The geometry, node locations, and the coordinate system for this element are shown in the above Figure 1. The element is defined by four nodes, four thicknesses, elastic foundation stiffness, and the orthotropic material properties. The thickness is supposed to vary smoothly over the area of the element, with the thickness input at the four nodes.

As the vibration grader assembly is fabricated with thin sheet metal plates of hot rolled steel the meshing is done using shell 63 elements. Mid surface extraction was done on the geometric model and all the surface model of vibration grader is imported into Ansys APDL and shell mesh was created. The corresponding thickness of each plate was assigned as the real constant in Ansys. The total number of elements created were 48744 and number of nodes created are 48226. Springs were replaced with spring damper Combination 14 elements as shown in the below figure.

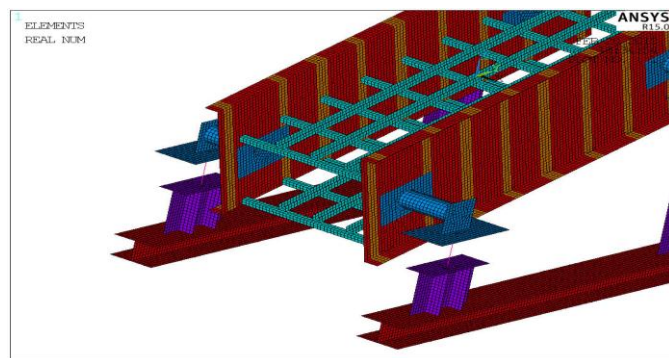

Figure -5.2.2 Finite element model of the structural members of Vibration grader assembly

5.3 Static Analysis of Vibration Grader Assembly

A static analysis can however include steady inertia loads and time varying loads that can be approximated as static equivalent loads. Static analysis is used to determine the displacements, stresses, strains and forces in structures or components caused by loads that do not induce significant inertia and damping effects. The objective of this analysis is to check the High stressed locations and deflections on the Vibration grader assembly for the applied loads and inertia load (self weight).

Boundary conditions applied on the Vibration grader assembly

- Base structural members constrained in all DOF as shown in the below figure.

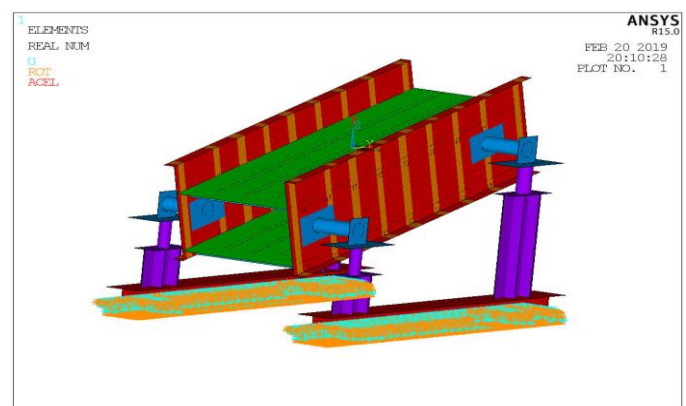

Figure -5.3.1 Base structure constrained in all DOF

- The weight of the coal particles is applied as a force load distributed over the screens as follows.

Coal Max. Weight on screen is = 679kg
 Force = 679*9.81 = 6664N (on top plate)
 Force = 679*9.81/2 = 3330N (on bottom plate)

- Gravity load of 9810 mm/s² is applied to apply self weight.

Results:

From the static analysis the deflections and stresses are calculated and plotted as shown in the below figures. Maximum deflection of 1.75 mm observed on the vibration grader.

Maximum VonMises stress of 54.7 Mpa is observed on the support structure of vibration grader as shown in the below figure. The yield stress of the material hot-rolled structural steel IS: 2062-1999, Grade A used for vibration grader is 250 Mpa. The obtained is VonMises stress is very much less compared to yield strength of the material. Therefore it is concluded that the vibration grader is safe for the above applied static loads with factor of safety of 410/54.7=7.4

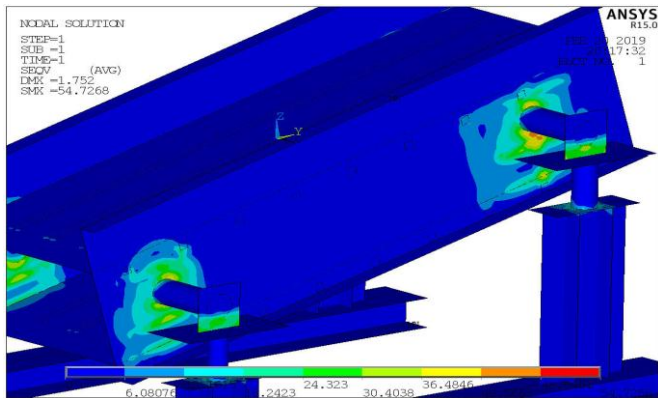

Figure -5.3.2: VonMises stress plot of vibration grader for static load

The summary of the results obtained for static analysis of vibration grader are tabulated in the below table.

S.No	Deflection (mm)	VonMises Stress (Mpa)	FOS
1	1.75	54.7	7.4

Table 5.3.1: Summary of results for static analysis

5.4 Dynamic Analysis of Vibration Grader Assembly

5.4.1 Model analysis:

Modal analysis was carried out to determine the natural frequencies and mode shapes of a structure. In general the large vibration graders operate in the range of 1500 - 7200 rpm (25 - 120 Hz). The vibration grader used in this project is a medium size grader which operates at 0 - 1500 rpm (0 - 25 Hz). Any structure will have 'n' of natural frequencies depending on its geometry and material. Since the maximum operating range of vibration grader in this project is 25 Hz, all the natural frequencies in the range of 0 - 25 Hz are calculated by doing modal analysis. The boundary conditions used in doing the modal analysis are:

- I sections base is arrested in all Dof for vibration.
- Gravity load is applied to include the self weight.

Results of Modal Analysis: A total of 7 natural frequencies are obtained in the frequency range of 0 - 25 Hz. The summary of the natural frequencies obtained is shown in the below table.

Mode No	Natural Frequency (Hz)	Natural Modes of Vibration
1	2.3609	Lateral Vibration along X-axis
2	8.7672	Oscillation vibration along Z-axis
3	10.672	To and Fro vibration along Y-

		Axis
4	14.135	Up and down Oscillation vibration along Z-axis
5	17.961	Side way Oscillation vibration along Z-axis
6	18.29	Front and Back oscillation vibration along Z-axis
7	21.539	Flexural oscillation of front and back of vibratory screen

Table 5.4.1.1: Modal calculation results of Vibration Grader

Mode shapes: Mode shapes gives the structure behavior at a particular natural frequency. The mode shapes for the natural frequencies mentioned in the above table are plotted as shown in the below figure.

Mode 1: The Mode 1 is obtained at a frequency of 2.36 Hz. The natural mode of vibration at this frequency is a Lateral Vibration along X-axis as shown in the below figure.

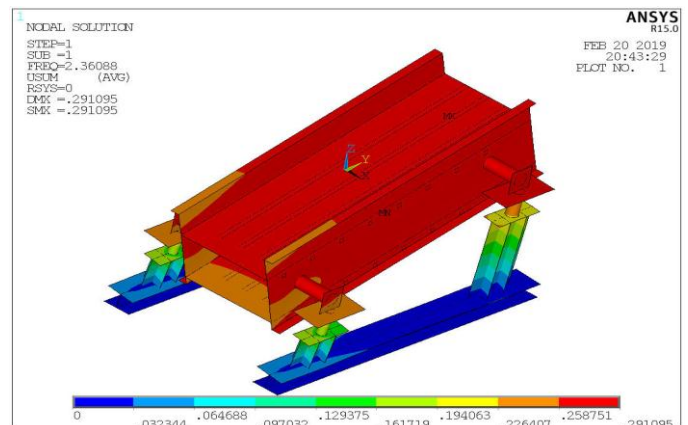

Figure -5.4.1.1: Mode 1@2.36 Hz for vibration grader

Mode 2: The Mode 2 is obtained at a frequency of 8.76 Hz. The natural mode of vibration at this frequency is a Oscillation vibration along Z-axis as shown in the below figure.

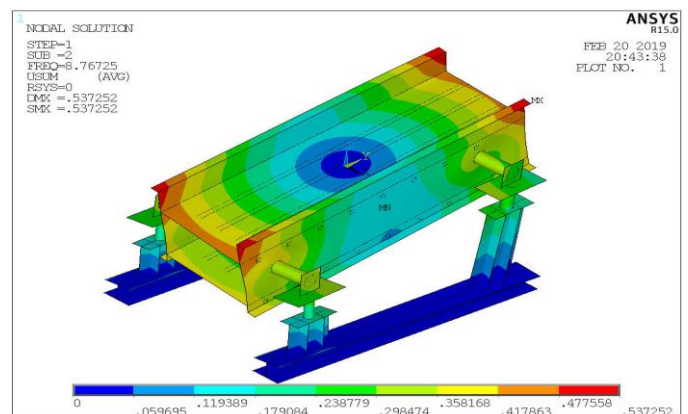

Figure -5.4.1.2: Mode 2@8.76 Hz for vibration grader

Mode 3: The Mode 3 is obtained at a frequency of 17.96 Hz. The natural mode of vibration at this frequency is a To and Fro vibration along Y-Axis as shown in the below figure.

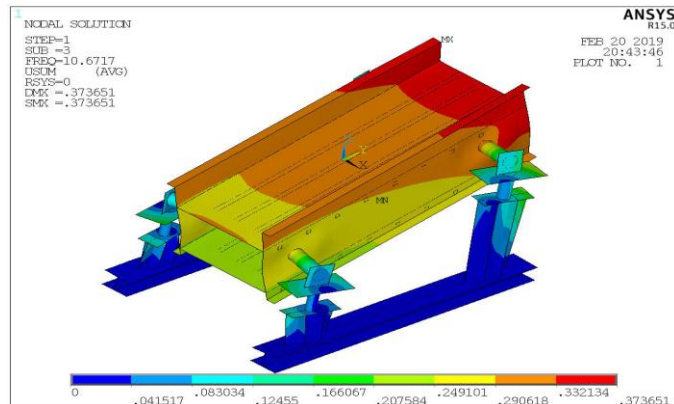

Figure -5.4.1.3: Mode3@10.67 Hz for vibration grader

Mode 4: The Mode 4 is obtained at a frequency of 14.13 Hz. The natural mode of vibration at this frequency is a Up and down Oscillation vibration along Z-axis as shown in the below figure.

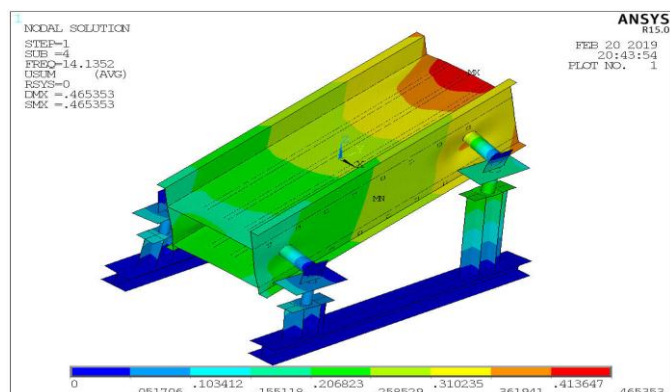

Figure -5.4.1.4: Mode 4@14.13 Hz for vibration grader

Mode 5: The Mode 5 is obtained at a frequency of 17.96 Hz. The natural mode of vibration at this frequency is a Side way Oscillation vibration along Z-axis as shown in the below figure.

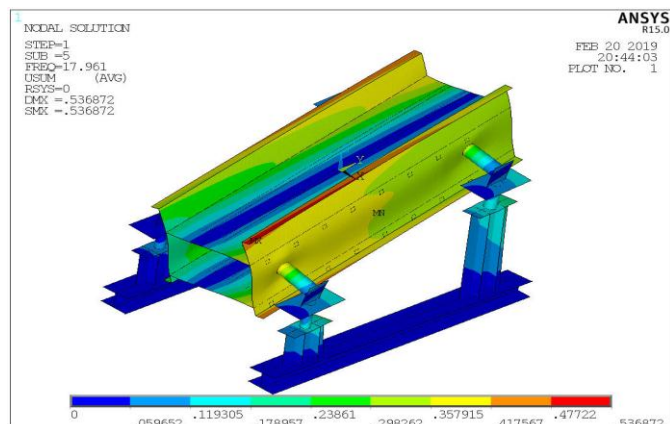

Figure -5.4.1.5: Mode 5@17.96 Hz for vibration grader

Mode 6: The Mode 6 is obtained at a frequency of 18.29 Hz. The natural mode of vibration at this frequency is a Front and Back oscillation vibration along Z-axis as shown in the below figure.

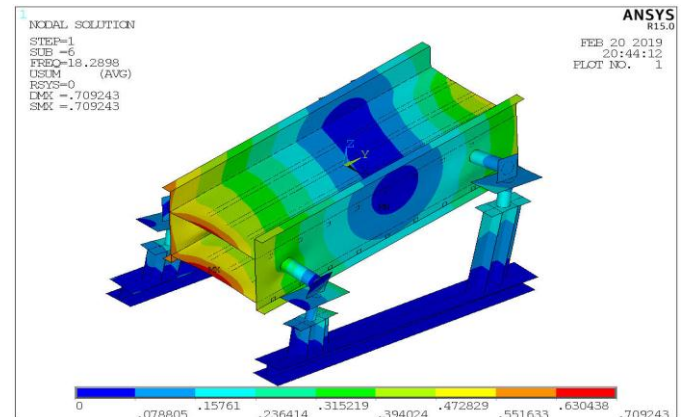

Figure -5.4.1.6: Mode 6@18.29 Hz for vibration grader

Mode 7: The Mode 7 is obtained at a frequency of 21.53 Hz. The natural mode of vibration at this frequency is a Flexural oscillation of front and back of vibratory screen as shown in the below figure.

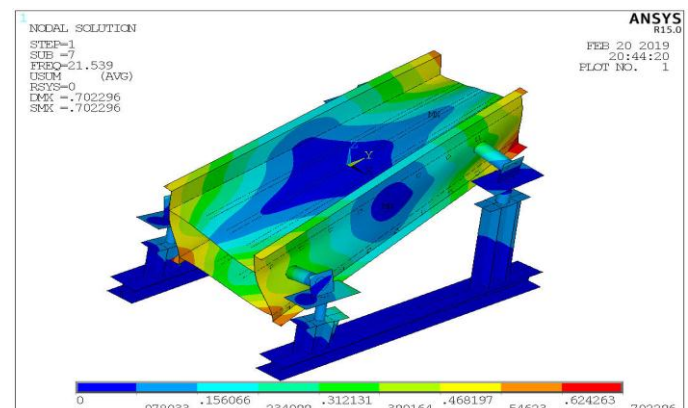

Figure -5.4.1.7: Mode 7@21.53 Hz for vibration grader

From the modal analysis it is observed that the first 6 vibration modes are deformable modes and modal frequency lies on the structural stiffness of the vibration grader. The 7th vibration mode is a flexural mode vibrating front and back. The result shows that the intensity of structure along the side plates is weaker and easy to break. This kind of vibration also does not help in screening of the particles. So the vibration Mode 7 is considered as the critical mode and it is required to shift this mode above the operating frequency of 25 Hz. However the mass participation of the vibrations modes are calculated to understand the structure behavior in detail at each of the natural frequency. The total mass of the structure is 18.18 Tons.

MODE	FREQUENCY (Hz)	EFFECTIVE MASS IN X-Dir (Tons)	EFFECTIVE MASS IN Y-Dir (Tons)	EFFECTIVE MASS IN Z-Dir (Tons)
1	2.36088	14.5653	1.39E-06	3.64E-06
2	8.76725	8.21E-03	6.35E-05	9.97E-05
3	10.6717	1.49E-05	11.4976	3.58E-02
4	14.1352	9.97E-05	0.167058	10.0001
5	17.961	8.55E-02	1.41E-02	4.52E-02
6	18.2898	2.18E-03	0.433991	0.730528
7	21.539	2.94E-03	3.87E-07	1.00E-04

Table 5.4.1.2: Mass participation in X,Y and Z directions for natural frequencies'

From the above table the following conclusions are made:

- The total mass of the structure is 18.18 Tons.
- A huge mass participation of 14.56 Tons (80 % of total mass) at a frequency of 2.36 Hz is observed in X-direction.
- A huge mass participation of 11.49 Tons (63 % of total mass) at a frequency of 10.67 Hz is observed in Y-direction.
- A huge mass participation of 10 Tons (55% of total mass) at a frequency of 14.13 Hz is observed in Z-direction.

Therefore when base excitation is given. To understand the structure behavior at the resonant condition and to find deflections and stresses at these frequencies a harmonic analysis has to be further carried out. To understand the structure behavior for base excitation and to find deflections and stresses at these frequencies

5.4.2 Harmonic analysis

Any continuous cyclic load will produce a continuous cyclic response (a harmonic response) in a structural system. Harmonic response analysis gives you the ability to calculate the continuous dynamic behavior of the structures, thus makes possible to verify whether or not the designs will successfully overcome resonance, fatigue, and other negative effects of forced vibrations. Harmonic response analysis is method used to determine the steady-state response of a linear structure to loads that vary sinusoidally (harmonically) with time. The method is to calculate the structure's response at several frequencies and obtain a graph of displacement versus frequency. Here we can identify peak responses on the graph and stresses reviewed at those peak frequencies.

Following three steps are useful under harmonic response analysis:

- Create and modify MODEL through design modular.
- Apply loads and supports to obtain the solution.

- Review and check the results.

Harmonic response takes place at forcing frequencies that match the natural frequencies of the structure. Before obtaining the harmonic solution, first determine the natural frequencies of the structure by obtaining a modal solution.

A harmonic analysis, by definition, assumes that any applied load varies harmonically (sinusoidal) with time. To completely identify a harmonic load, three pieces of information are usually required: the amplitude, the phase angle, and the forcing frequency range

Harmonic analysis was carried out to determine the operating frequencies, deflections and stress of a structure in the frequency range of 0 -25 Hz. The number of sub steps is given as 100, so that results are calculated at an interval of 0.25 intervals. The boundary conditions applied for harmonic analysis are as follows:

- Base structural members constrained in all DOF as shown in the below figure.
- The weight of the coal particles is applied as a force load distributed over the screens.

Coal Max. Weight on screen is = 679kg
 Force = 679*9.81 = 6664N (on top plate)
 Force = 679*9.81/2 = 3330N (on bottom plate)
 Gravity load of 9810 mm/s is applied to apply self weight.

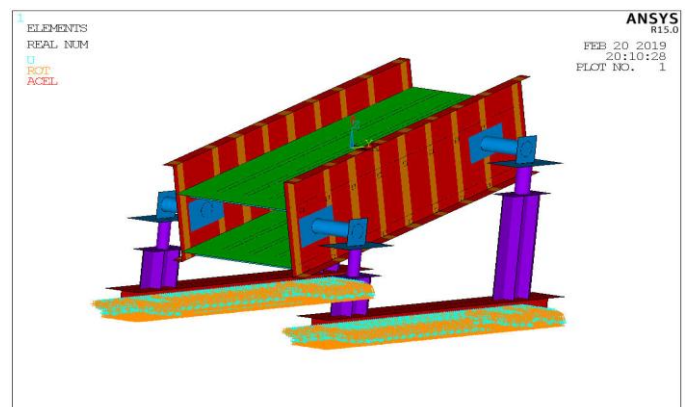
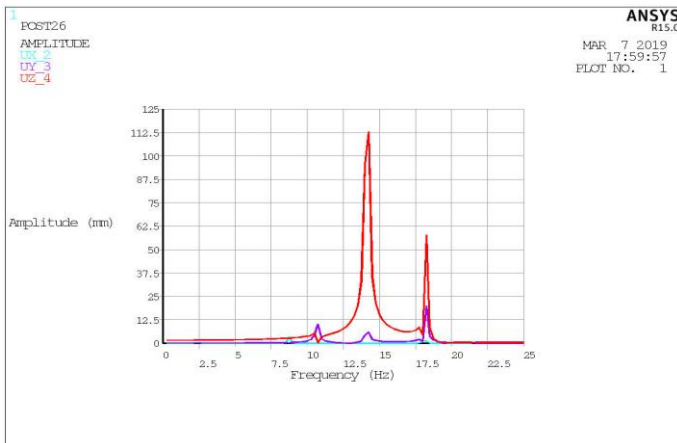

Figure 5.4.2.1: Base structure constrained in all DOF for harmonic analysis

Results of Harmonic analysis: From the harmonic analysis graphs are plotted between Frequency Vs Amplitude over the frequency range of 0 to 25 Hz to understand the amplitude at different frequencies. The graphs are plotted by taking four different locations (top plate, bottom plate, side plates and the supports).

Frequency Vs amplitude on top plate: Frequency Vs amplitude graph is plotted on the top plate of the vibratory grader as shown below. From the graph it is observed that the maximum amplitude of 112.5 mm is observed at 14.67 Hz in Z-direction.



Graph 5.4.2.1: Frequency Vs Amplitude on top plate of vibration grader

Frequency Vs amplitude on bottom plate: Frequency Vs amplitude graph is plotted on the bottom plate of the vibratory grader as shown below. From the graph it is observed that the maximum amplitude of 97 mm is observed at 14.67 Hz in Z-direction.

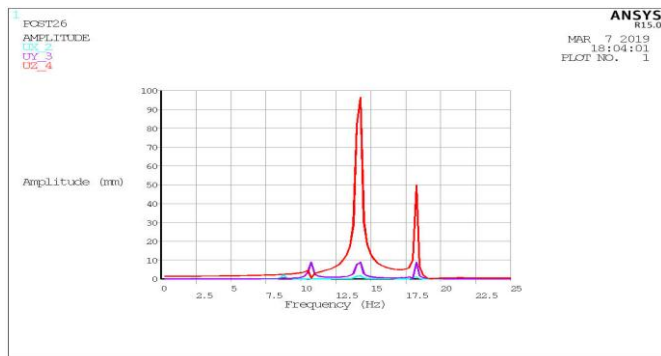

Graph 5.4.2.2: Frequency Vs Amplitude on bottom plate of vibration grader

Frequency Vs amplitude on side plate: Frequency Vs amplitude graph is plotted on the side plate of the vibratory grader as shown below. From the graph it is observed that the maximum amplitude of 80 mm is observed at 14.67 Hz in Z-direction.

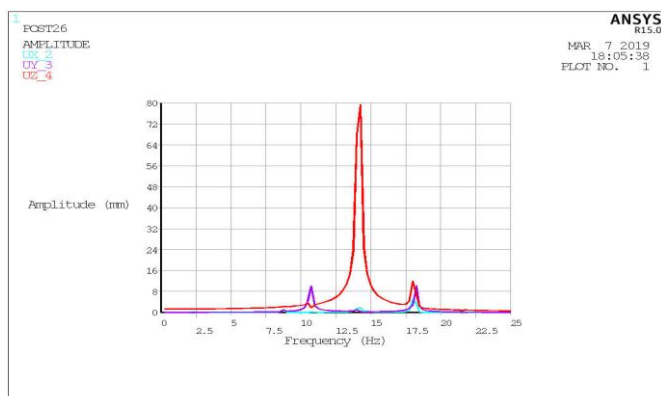

Graph 5.4.2.3: Frequency Vs Amplitude on side plate of vibration grader

Frequency Vs amplitude on support leg: Frequency Vs amplitude graph is plotted on the support leg of the vibratory grader as shown below. From the graph it is observed that the maximum amplitude of 56 mm is observed at 14.67 Hz in X-direction.

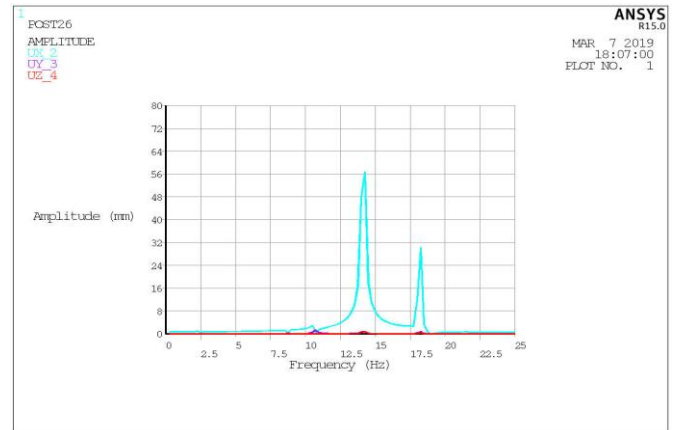

Graph 5.4.2.4: Frequency Vs Amplitude on support leg of vibration grader

Deflections and stresses at the critical frequencies:

Deflection and stresses are plotted at the resonant frequencies obtained from modal analysis to check whether the structure is withstanding the operating loads or sinusoidal loads at the resonant frequencies. The resonant frequencies obtained from the modal analysis are 2.36 Hz, 10.67 Hz and 14.13 Hz. The deflections and stresses at these resonant frequencies are plotted as shown below.

Deflection at 2.36 Hz: A maximum total deflection of 1.8 mm observed on the top plate of the vibration grader at a resonant frequency of 2.36 Hz as shown in the below figure.

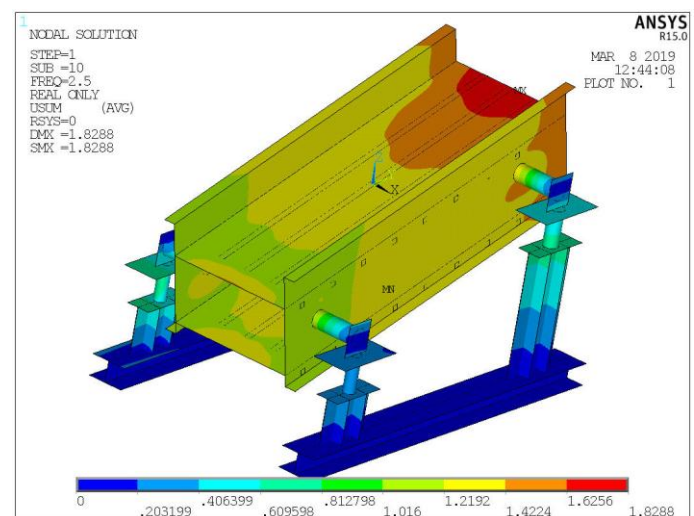

Figure 5.4.2.2: Total deflection of vibration grader at resonant frequency of 2.36 Hz

VonMises Stress at 2.36 Hz: Maximum VonMises stress of 56.2 Mpa observed on the side plate at a resonant frequency of 2.36 Hz as shown in the below figure.

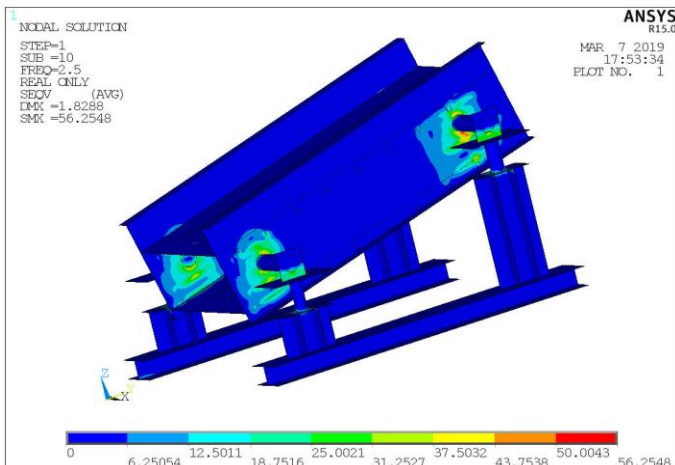

Figure 5.4.2.3: VonMises stress of vibration grader at resonant frequency of 2.36 Hz

Deflection at 10.67 Hz: A maximum total deflection of 11 mm observed on the top plate of the vibration grader at a resonant frequency of 10.67 Hz as shown in the below figure.

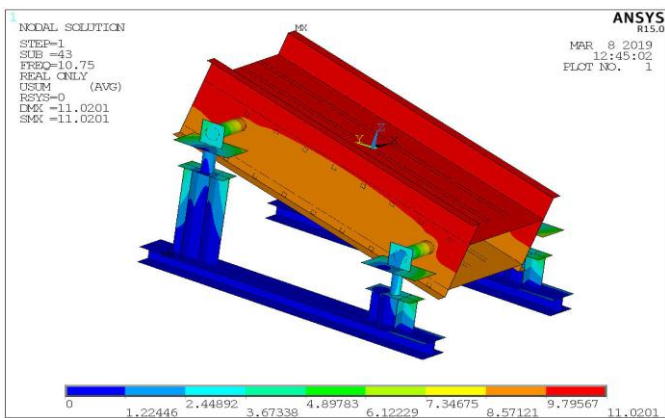

Figure 5.4.2.4: Total deflection of vibration grader at resonant frequency of 10.67 Hz

VonMises Stress at 10.67 Hz: Maximum VonMises stress of 340 Mpa observed on the side plate at a resonant frequency of 10.67 Hz as shown in the below figure.

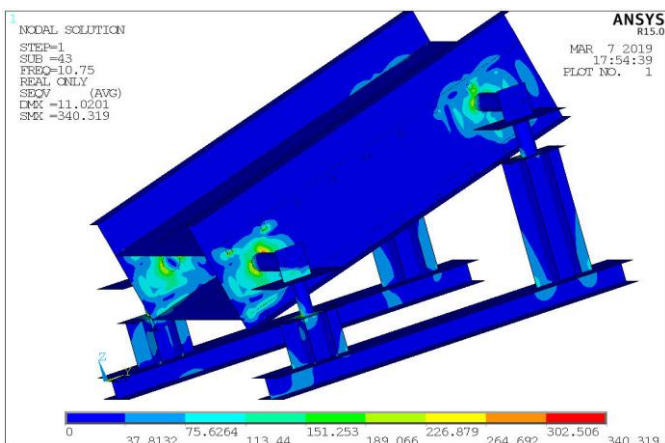

Figure 5.4.2.5: VonMises stress of vibration grader at resonant frequency of 10.67 Hz

Deflection at 14.13 Hz: A maximum total deflection of 104 mm observed on the top plate of vibration grader at a resonant frequency of 14.13 Hz as shown below .

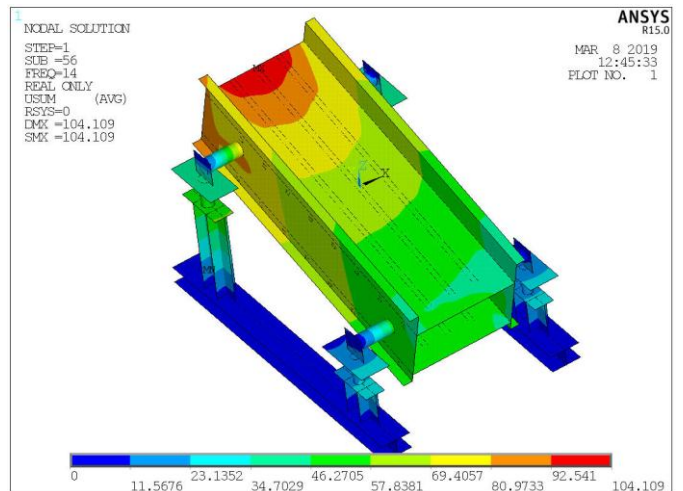

Figure 5.4.2.6: Total deflection of vibration grader at resonant frequency of 14.13 Hz

VonMises Stress at 14.13 Hz: Maximum VonMises stress of 3132 Mpa observed on the side plate at a resonant frequency of 14.13 Hz as shown in the below figure.

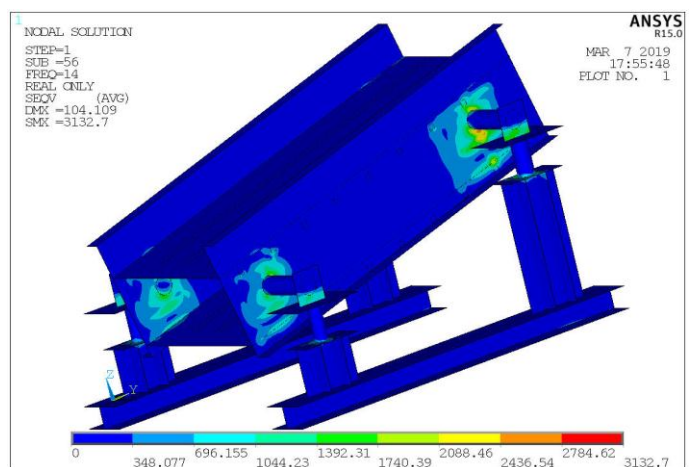

Figure 5.4.2.7: VonMises stress of vibration grader at resonant frequency of 14.13 Hz

The results obtained at the resonant frequencies from harmonic analysis are tabulated below as shown in the below table.

S.No	Resonant Frequency (Hz)	Deflection (mm)	VonMises Stress (Mpa)
1	2.36	1.8	56.2
2	10.67	11	340
3	14.13	104	3132

Table 5.4.2.1: Results summary at resonant frequencies

From the above results the following conclusions are made:

- The yield strength of the steel material used for vibration grader is 410 Mpa obtained from material properties.
- The VonMises stress obtained at resonant frequency of 2.36 Hz is 56.2 Mpa. The factor of safety (FOS) is $410/56.2 = 7.2$. As the FOS is more than 1, it is concluded that the vibration grader is safe for the resonant frequency of 2.36 Hz.
- The VonMises stress obtained at resonant frequency of 10.67 Hz is 340 Mpa. The factor of safety (FOS) is $410/340 = 1.2$. As the FOS is more than 1, it is concluded that the vibration grader is safe for the resonant frequency of 10.67 Hz.
- The VonMises stress obtained at resonant frequency of 14.13 Hz is 3132 Mpa. The factor of safety (FOS) is $410/3132 = 0.13$. As the FOS is less than 1, it is concluded that the vibration grader is not safe for the resonant frequency of 14.13 Hz.

Therefore the modifications are required on the vibration grader to shift the critical resonant frequencies by adding the stiffeners. The location of modifications required can be identified from the mode shapes obtained from the modal analysis. The modifications are made on the vibration grader assembly by adding gussets on side plate and additional rib for screen supports as shown in the below figures.

5.5 Modifications

Modification #1 : The support legs of the vibration grader are strengthened by adding the extra stiffeners.

Modification #2 : Gussets are added on the side plates of the vibration grader are as shown in the below figures

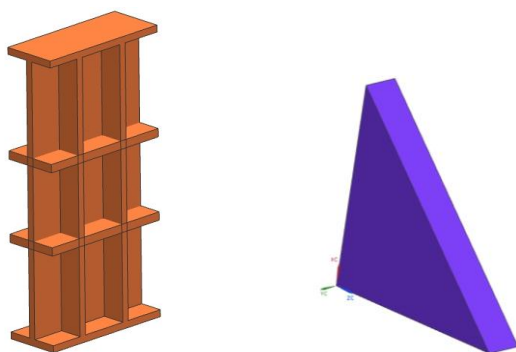

Figure 5.5.1: Extra ribs added for support legs, Gussets added to side plates of vibration grader

Modification #3 : Extra ribs added on the side plates of the vibration grader are as shown in the below figure.

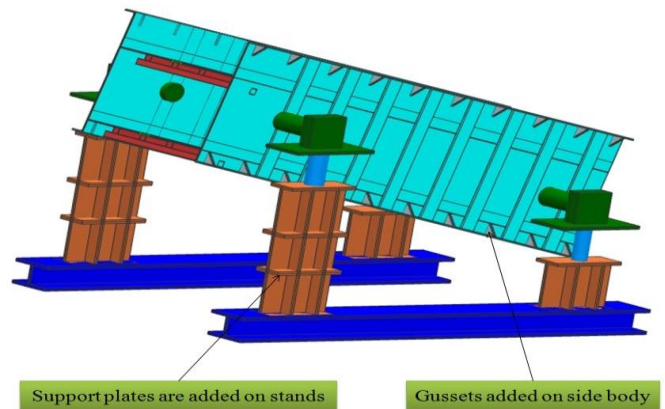

Figure 5.5.2: Modified model of the vibratory grader assembly

6. STRUCTURAL ANALYSIS OF MODIFIED VIBRATION GRADER ASSEMBLY

3D model of the modified vibration grader assembly was developed in UNIGRAPHICS from the analysis results obtained. The model was then converted into a parasolid to import into ANSYS. A Finite Element model was developed with shell elements. The elements that are used for idealizing the modified vibration grader assembly were described in the above chapters.

The elements that are used for idealizing the vibration grader assembly are Shell 63.

MATERIAL PROPERTIES:

All the components of the modified Vibration grader assembly are made using hot-rolled structural steel IS: 2062-1999, Grade A, Fe 410WA. All the components of the modified vibration grader assembly are assigned as per the below material properties.

Steel IS: 2062-1999 Mechanical Properties:

Young's modulus = 200Gpa
 Yield Strength = 410 Mpa
 Tensile Strength = 250 Mpa

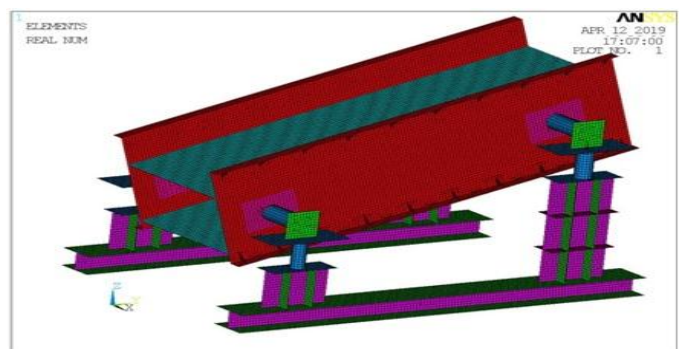

Figure 6: Finite element model of the Modified Vibration grader assembly

6.1 Static Analysis of Modified Vibration Grader Assembly

Static analysis was performed to check the High stressed locations and deflections on the Modified Vibration grader assembly for the applied loads and inertia load.

Boundary conditions applied on the Modified vibration grader assembly

The boundary conditions applied are same as applied to the original vibration grader as shown below.

- The weight of the coal particles is applied as a force load distributed over the screens.
- Coal Max. Weight on screen is = 679kg
- Force = $679 \times 9.81 = 6664\text{N}$ (on top plate)
- Force = $679 \times 9.81 / 2 = 3330\text{N}$ (on bottom plate)
- Gravity load of 9810 mm/s is applied to apply self weight.

Results:

From the static analysis the deflections and stresses are calculated and plotted as shown in the below figures. Maximum deflection of 1.14 mm observed on the vibration grader as shown in the below figure.

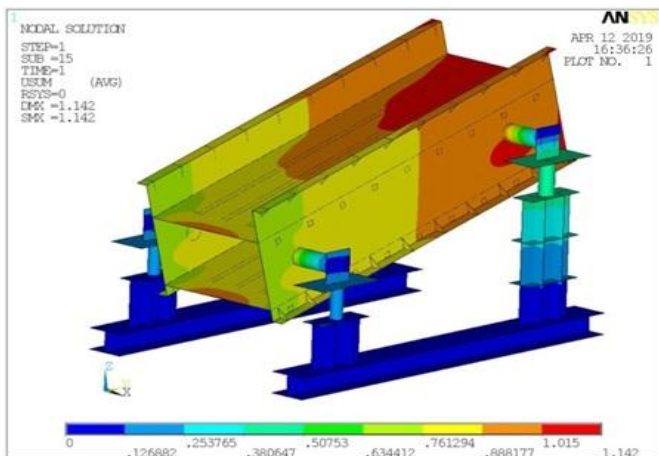

Figure 6.1.1: Total deflection of Modified Vibration grader assembly

Von mises Stress:

Maximum VonMises stress of 47.9 Mpa is observed on the support structure of vibration grader as shown in the below figure. The yield stress of the material hot-rolled structural steel IS: 2062-1999, Grade A used for vibration grader is 410 Mpa. The obtained is VonMises stress is very much less compared to yield strength of the material. Therefore it is concluded that the modified vibration grader is safe for the above applied static loads with factor of safety of $410/47.9=8.5$

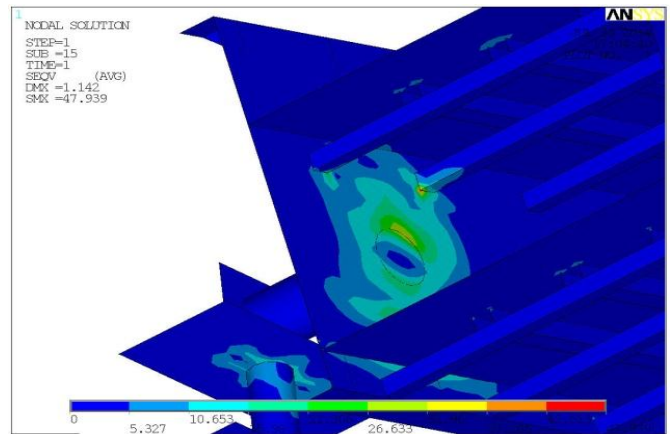

Figure 6.1.2: Von mises stress for Modified Vibration grader assembly

The summary of the results obtained for static analysis of modified vibration grader are tabulated in the below table.

S.No	Deflection (mm)	VonMises Stress (Mpa)	FOS
1	1.15	47	8.5

Table 6.1: Summary of results for static analysis for modified vibration grader

6.2 Dynamic Analysis of Modified Vibration Grader Assembly

Model analysis on modified vibration grader

Modal analysis was carried out to determine the natural frequencies and mode shapes of a structure. In general the large vibration graders operate in the range of 1500 - 7200 rpm (25 - 120 Hz). The vibration grader used in this project is a medium size grader which operates at 0 - 1500 rpm (0 - 25 Hz). Any structure will have 'n' of natural frequencies depending on its geometry and material. Since the maximum operating range of vibration grader in this project is 25 Hz, all the natural frequencies in the range of 0 - 25 Hz are calculated by doing modal analysis. The boundary conditions used in doing the modal analysis are:

- I sections base is arrested in all Dof for modified vibration Grader assembly.
- Gravity load is applied to include the self weight.

Results of Modal Analysis: A total of 4 natural frequencies are obtained in the frequency range of 0 - 25 Hz. The summary of the natural frequencies obtained is shown in the below table.

Mode No	Natural Frequency (Hz)	Natural Modes of Vibration
1	5.4	Up and down Oscillation vibration along Z-axis

2	10.24	Side way Oscillation vibration along Z-axis
3	11.69	Up and down Oscillation vibration along Z-axis
4	13.3	Up and down Oscillation vibration along Z-axis

Table 6.2.1 : Modal calculation results of modified Vibration Grader

Mode shapes: Mode shapes gives the structure behavior at a particular natural frequency. The mode shapes for the natural frequencies mentioned in the above table are plotted. as shown in the below figure.

Mode 1: The Mode 1 is obtained at a frequency of 5.4 Hz. The natural mode of vibration at this frequency is a Up and down Oscillation vibration along Z-axis.

Mode 2: The Mode 2 is obtained at a frequency of 10.24 Hz. The natural mode of vibration at this frequency is a Side way Oscillation vibration along Z-axis.

Mode 3: The Mode 3 is obtained at a frequency of 11.69 Hz. The natural mode of vibration at this frequency is a Up and down Oscillation vibration along Z-axis.

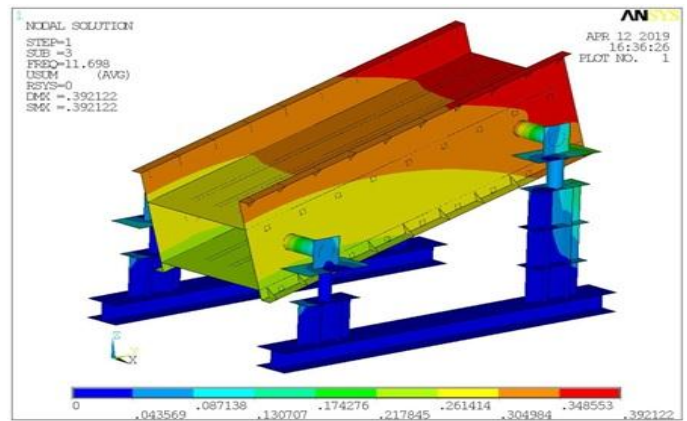

Figure 6.2.3: Mode shape 3@11.69Hz for Modified Vibration grader assembly.

Mode 4: The Mode 3 is obtained at a frequency of 13.32 Hz. The natural mode of vibration at this frequency is a Up and down Oscillation vibration along Z-axis as shown in the below figure.

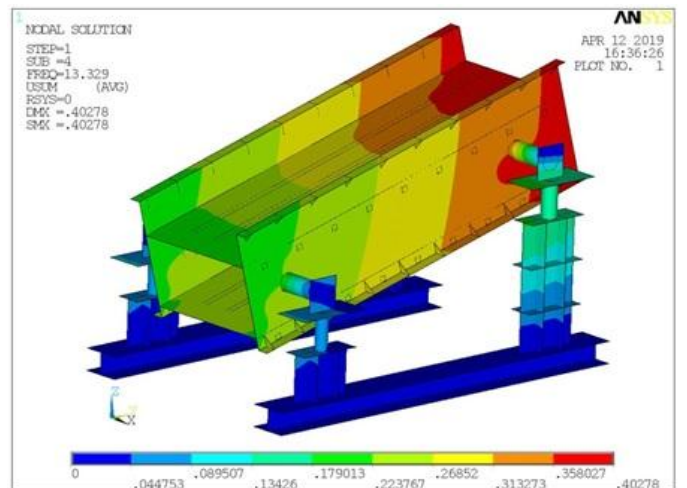

Figure 6.2.4: Mode shape 4@13.32Hz for Modified Vibration grader assembly.

From the modal analysis it is observed that the first 4 vibration modes are deformable modes and modal frequency lies on the structural stiffness of the vibration grader. However the mass participation of the vibrations modes are calculated to understand the structure behavior in detail at each of the natural frequency. The total mass of the structure is 20.1Tons.

MO DE	FREQUEN CY (Hz)	EFFECTIVE MASS IN X-Dir (Tons)	EFFECTIVE MASS IN Y-Dir (Tons)	EFFECTIVE MASS IN Z-Dir (Tons)
1	5.4	4.38	0.1E-06	0.2E-06
2	10.24	0.46	0.24E-06	0.25E-05
3	11.69	0.5E-09	1.12	0.91E-01
4	13.3	0.7E-05	0.29	3

Table 6.2.2 : Mass participation in all directions for natural frequencies for modified vibration grader

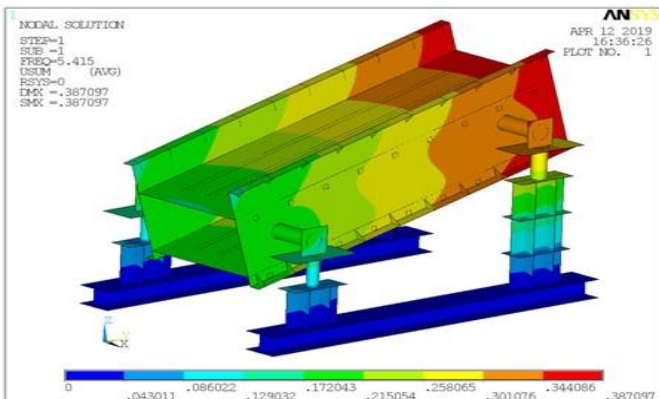

Figure 6.2.1: Mode shape 1@5.4 Hz for Modified Vibration grader assembly

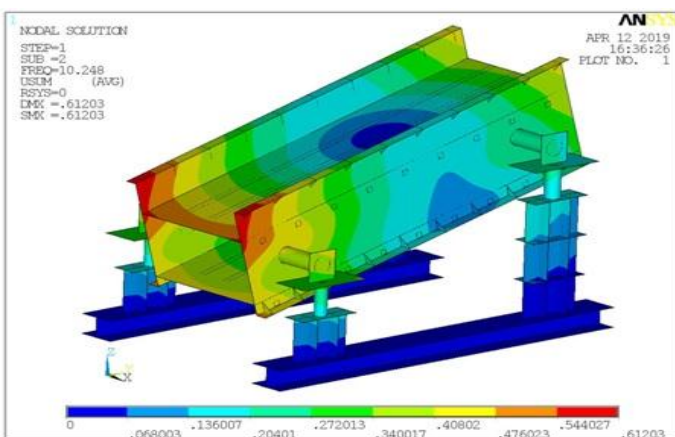

Figure 6.2.2: Mode shape 2@10.24Hz for Modified Vibration grader assembly.

From the above table the following conclusions are made:

- The total mass of the structure is 20.1 Tons.
- A mass participation of 4.38 Tons (21.1 % of total mass) at a frequency of 5.4 Hz is observed in X-direction.
- A mass participation of 1.12 Tons (5.5 % of total mass) at a frequency of 11.69 Hz is observed in Y-direction.
- A mass participation of 3 Tons (14.9 % of total mass) at a frequency of 13.3 Hz is observed in Z-direction.

Therefore the frequencies 4.38 Hz, 11.69 Hz and 13.3 Hz are having mass participations less than 25 % of the total mass. However these frequencies are likely to get amplified when a resonance occurs or when base excitation is given. To understand the structure behavior at the resonant condition and to find deflections and stresses at these frequencies a harmonic analysis has to be further carried out.

6.3 Harmonic Response Analysis of Modified Vibration Grader

Harmonic analysis was carried out to determine the operating frequencies, deflections and stress of a structure in the frequency range of 0 -25 Hz. The number of sub steps is given as 100, so that results are calculated at an interval of 0.25 intervals. The boundary conditions applied for harmonic analysis are as follows:

- Base structural members constrained in all DOF.
- The weight of the coal particles is applied as a force load distributed over the screens.

Coal Max. Weight on screen is = 679kg
 Force = 679*9.81 = 6664N (on top plate)
 Force = 679*9.81/2 = 3330N (on bottom plate)

- Gravity load of 9810 mm/s is applied to apply self weight.

Results of Harmonic analysis: From the harmonic analysis graphs are plotted between Frequency Vs Amplitude over the frequency range of 0 to 15 Hz to understand the amplitude at different frequencies. The graphs are plotted by taking four different locations (top plate, bottom plate, side plates and the supports).

Frequency Vs amplitude on top plate: Frequency Vs amplitude graph is plotted on the top plate of the modified vibratory grader as shown below. From the graph it is observed that the maximum amplitude of 0.105 mm is observed at 13.3 Hz in Z-direction.

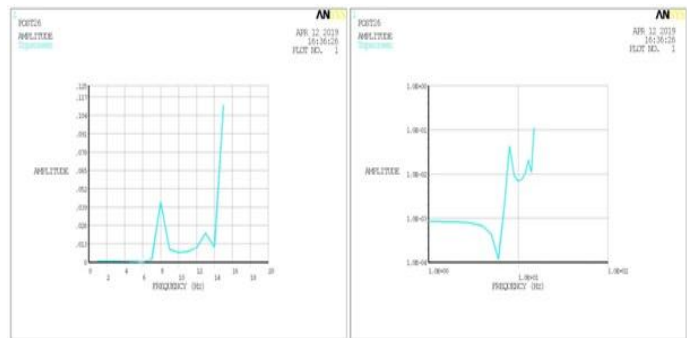

Graph 6.3.1: Frequency Vs Amplitude on top plate in linear and log scale for modified vibration grader

Frequency Vs amplitude on side plate: Frequency Vs amplitude graph is plotted on the side plate of the modified vibratory grader as shown below. From the graph it is observed that the maximum amplitude of 0.036 mm is observed at 5.4 Hz in X-direction.

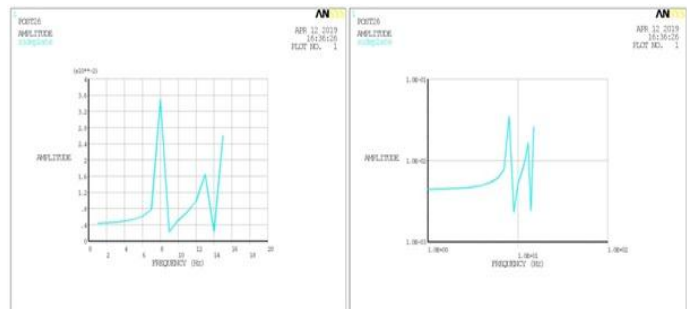

Graph 6.3.2: Frequency Vs Amplitude on side plate in linear and log scale for modified vibration grader

Frequency Vs amplitude on support leg: Frequency Vs amplitude graph is plotted on the support leg of the modified vibratory grader as shown below. From the graph it is observed that the maximum amplitude of 2.5 mm is observed at 13.3 Hz in Z-direction.

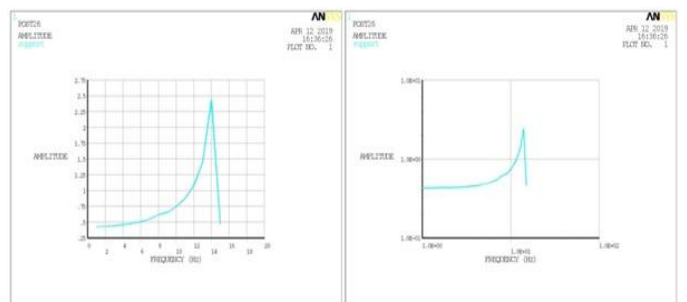

Graph 6.3.3: Frequency Vs Amplitude on support in linear and log scale for modified vibration grader

Frequency Vs amplitude on bottom screen: Frequency Vs amplitude graph is plotted on the bottom plate of the modified vibratory grader as shown below. From the graph it is observed that the maximum amplitude of 0.05 mm is observed at 13.3 Hz in Z-direction.

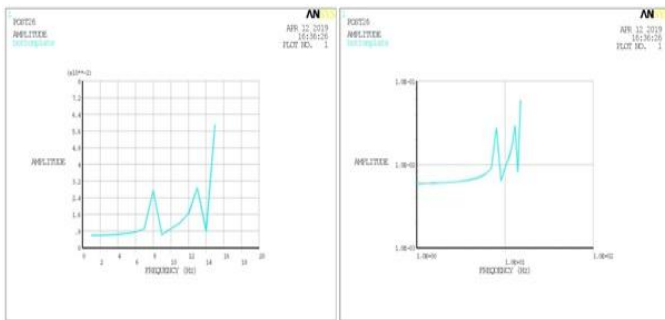

Graph 6.3.4: Frequency Vs Amplitude on bottom in linear and log scale for modified vibration grader

Deflections and stresses at the critical frequencies:

Deflection and stresses are plotted at the resonant frequencies obtained from modal analysis to check whether the structure is withstanding the operating loads or sinusoidal loads at the resonant frequencies. The resonant frequencies obtained from the modal analysis are 5.4 Hz, 11.69 Hz and 13.3 Hz. However the mass participation for 11.69 Hz is very less (5%), so the stresses and deflections are plotted only at 5.4 Hz and 13.3 Hz. The deflections and stresses nearest to these resonant frequencies are plotted as shown below.

Deflection at 5.4 Hz: A maximum total deflection of 1.5 mm observed on the top plate of the vibration grader at a resonant frequency of 5.4 Hz.

VonMises Stress at 5.4 Hz: Maximum VonMises stress of 60 Mpa observed on the side plate at a resonant frequency of 5.4 Hz as shown in the below figure.

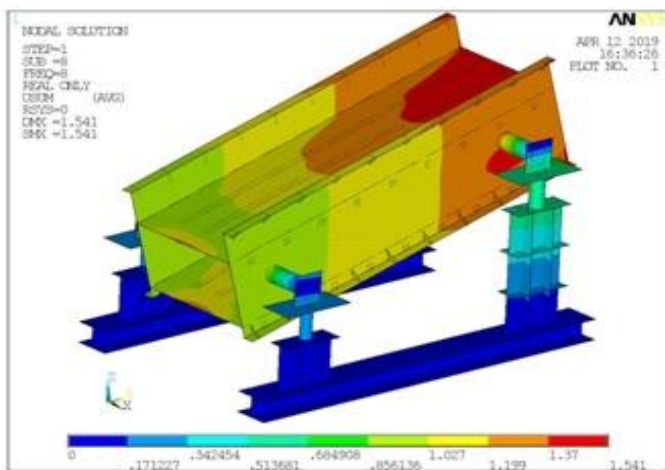

Figure 6.3.1: Total deflection of modified vibration grader at resonant frequency of 5.4 Hz

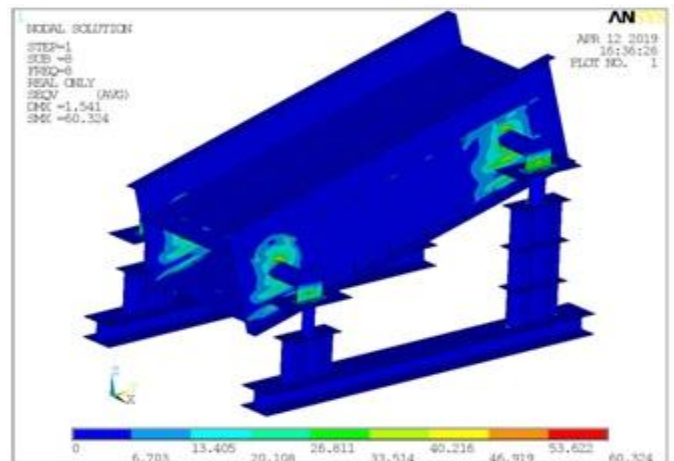

Figure 6.3.2: VonMises of modified vibration grader at resonant frequency of 5.4 Hz

Deflection at 13.3 Hz: A maximum total deflection of 3.5 mm observed on the top plate of the vibration grader at a resonant frequency of 13.3 Hz as shown in the below figure.

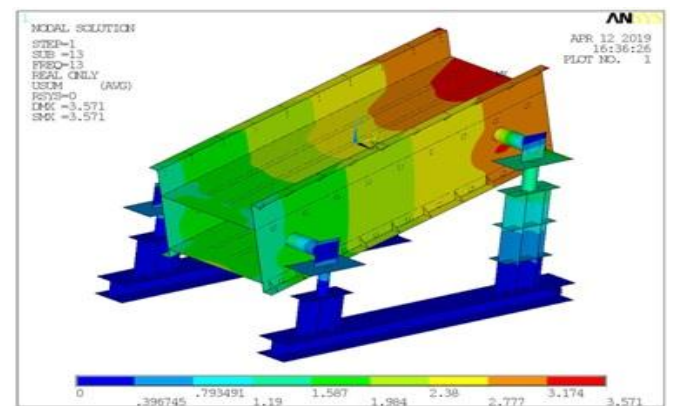

Figure 6.3.3: Total deflection of modified vibration grader at resonant frequency of 13.3 Hz

VonMises Stress at 13.3 Hz: Maximum VonMises stress of 100.3 Mpa observed on the side plate at a resonant frequency of 13.3 Hz as shown in the below figure.

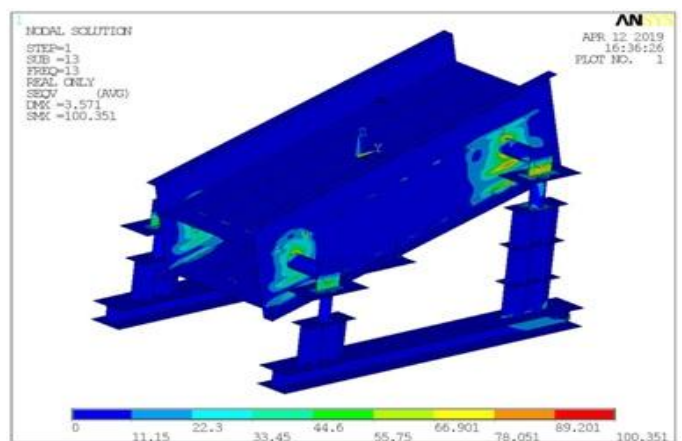

Figure 6.3.4: VonMises of modified vibration grader at resonant frequency of 13.3 Hz

The results obtained at the resonant frequencies from harmonic analysis are tabulated below as shown in the below table.

S. No	Resonant Frequency (Hz)	Deflection (mm)	VonMises Stress (Mpa)
1	5.4	1.5	60
2	13.3	3.5	100.3

Table 6.3 : Results summary at resonant frequencies

From the above results the following conclusions are made:

- The yield strength of the steel material used for vibration grader is 410 Mpa obtained from material properties.
- The VonMises stress obtained at resonant frequency of 5.4 Hz is 60 Mpa. The factor of safety (FOS) is $410/60 = 6.8$. As the FOS is more than 1, it is concluded that the modified vibration grader is safe for the resonant frequency of 5.4 Hz.
- The mass participation at 11.69 Hz is very less, i.e. only 5% of the total mass. So there will be no excitations at this resonant frequency because of low mass participation. Hence it is concluded that the modified vibration grader is safe for the resonant frequency of 11.69 Hz.
- The VonMises stress obtained at resonant frequency of 13.3 Hz is 100.3 Mpa. The factor of safety (FOS) is $410/100.3 = 4.08$. As the FOS is more than 1, it is concluded that the modified vibration grader is safe for the resonant frequency of 13.3 Hz.

7. RESULTS AND DISCUSSION

Structural analysis:

Static analysis is used to determine the displacements, stresses, strains and forces in structures or components caused by loads

- From the static analysis the deflections and stresses are calculated. Maximum deflection of 1.75 mm observed and Maximum VonMises stress of 54.7 Mpa is observed on the support structure of vibration grader and factor of safety of 7.4

Model analysis:

Modal analysis was carried out to determine the natural frequencies and mode shapes of a structure. The vibration grader used in this project is a medium size grader which operates at 0 - 1500 rpm (0 - 25 Hz)

A total of 7 natural frequencies are obtained in the frequency range of 0 - 25 Hz. The total mass of the structure is 18.18 Tons.

- A huge mass participation of 14.56 Tons (80 % of total mass) at a frequency of 2.36 Hz is observed in X-direction.
- A huge mass participation of 11.49 Tons (63 % of total mass) at a frequency of 10.67 Hz is observed in Y-direction.
- A huge mass participation of 10 Tons (55% of total mass) at a frequency of 14.13 Hz is observed in Z-direction.

Harmonic analysis: Harmonic response analysis gives you the ability to calculate the continuous dynamic behavior of the structures.

- The resonant frequencies obtained from the modal analysis are 2.36 Hz, 10.67 Hz and 14.13 Hz
- The VonMises stress obtained at resonant frequency of 2.36 Hz is 56.2 Mpa. The factor of safety (FOS) is $410/56.2 = 7.2$. As the FOS is more than 1, it is concluded that the vibration grader is safe for the resonant frequency of 2.36 Hz.
- The VonMises stress obtained at resonant frequency of 10.67 Hz is 340 Mpa. The factor of safety (FOS) is $410/340 = 1.2$. As the FOS is more than 1, it is concluded that the vibration grader is safe for the resonant frequency of 10.67 Hz.
- The VonMises stress obtained at resonant frequency of 14.13 Hz is 3132 Mpa. The factor of safety (FOS) is $410/3132 = 0.13$. As the FOS is less than 1, it is concluded that the vibration grader is not safe for the resonant frequency of 14.13 Hz

Structural analysis on modified structure:

- Static analysis was performed to check the High stressed locations and deflections on the Modified Vibration grader assembly for the applied loads and inertia load. Maximum deflection of 1.14 mm observed and Maximum VonMises stress of 47.9 Mpa is observed on the support structure and Factor of safety of 8.5

Model analysis on modified structure:

A total of 4 natural frequencies are obtained in the frequency range of 0 - 25 Hz. The total mass of the structure is 20.1 Tons.

- A mass participation of 4.38 Tons (21.1 % of total mass) at a frequency of 5.4 Hz is observed in X-direction.
- A mass participation of 1.12 Tons (5.5 % of total mass) at a frequency of 11.69 Hz is observed in Y-direction.
- A mass participation of 3 Tons (14.9 % of total mass) at a frequency of 13.3 Hz is observed in Z-direction.
- Therefore the frequencies 4.38 Hz, 11.69 Hz and 13.3 Hz are having mass participations less than 25 % of the total mass. However these frequencies are likely to get amplified when a resonance occurs

Harmonic analysis on modified structure:

- The VonMises stress obtained at resonant frequency of 5.4 Hz is 60 Mpa. The factor of safety (FOS) is $410/60 = 6.8$. As the FOS is more than 1, it is concluded that the modified vibration grader is safe for the resonant frequency of 5.4 Hz.
- The mass participation at 11.69 Hz is very less i.e. only 5% of the total mass. So there will be no excitations at this resonant frequency because of low mass participation. Hence it is concluded that the modified vibration grader is safe for the resonant frequency of 11.69 Hz.
- The VonMises stress obtained at resonant frequency of 13.3 Hz is 100.3 Mpa. The factor of safety (FOS) is $410/100.3 = 4.08$. As the FOS is more than 1, it is concluded that the modified vibration grader is safe for the resonant frequency of 13.3 Hz.

8. CONCLUSION

In this research the dynamic behavior of the vibration grader was studied by performing the finite element analysis. 3D model of the existing vibration grader was developed using NX_CAD software. Static analysis was carried out on the original model for operating loads and found that the design was safe for static loads. Modal analysis was performed followed by harmonic analysis to determine the resonant frequencies and found that the vibration grader was not safe for the resonant frequency of 14.13 Hz. Later modifications were made on the vibration grader assembly by adding gussets on side plate and additional rib for screen supports. Modal analysis was performed followed by harmonic analysis to determine the resonant frequencies and found that the modified vibration grader is safe at the resonant frequencies. From the analysis results it is concluded that the modified vibration screen is safe for the operating dynamic loads.

REFERENCES

- [1] Dynamic design theory and application of large vibrating screen by Zhao Yue-mina, Liu Chu-sheng, He Xiao-mei, Procedia Earth and Planetary Science 1 (2009) pp 776-784.
- [2] Design of Vibratory Screen used in Coal Mining Industry to Prevent Failure – A Case Study by DR. BHAVESH P. PATEL Vol. 1, Issue:1, February 2013 (IJRMEET) ISSN:2320-6586, pp 14-18.
- [3] Statics and modal analysis for large vibrating screen by He wen-feng, Xian a-man, ISSN: 1662-7482, Vols. 380-384, pp 136-139.
- [4] Dynamic analysis of large vibrating screen by. Wenying Li, Shibo Xiong
- [5] Noise controls for vibrating screen mechanisms by M.J. Lowe, D.S. Yantek, H.E. Camargo and L.A. Alcorn, Noise Control Eng J. 2013 March 1 pp 127-144.
- [6] Study and Analysis of Deck inclination angle on Efficiency of Vibration Screen by Gunaji Ashok Sawant, V. Murali Mohan, Sandip Ashok Sawant, 2016 IJEDR | Volume 4, Issue 1 | ISSN: 2321-9939, pp 631-634.
- [7] DEM simulation of screening operation of banana screens by liggghts by M. Jahani, A. Farzanegan, M. Noaparast, S.Z. Shafaei. 19-21, 2016 pp 1058-1072.
- [8] Failure and sensitivity analysis of a reconfigurable vibrating screen using finite element analysis Boitumelo Ramatsetse, Khumbulani Mpofu, Olasumbo Makinde. 9 (2017) pp 40-51
- [9] Intelligent Prediction of Sieving Efficiency in Vibrating Screens by BinZhang, JinkeGong, WenhuaYuan, JunFu, and YiHuang. Volume 2016, Article ID 9175417, 7 pages
- [10] Cam & Follower Operated Multi-Level Vibrating Screening Machine by Pawar Santosh R., Daunde Suyog A., Sonawane Ennath S., Dange Akash C., Asst. Prof. S.S. Aher, Asst. Prof. Darade P.P, Volume: 04 Issue: 04 | Apr - 2017, pp 75-77.
- [11] Nonlinear Model of Vibrating Screen to Determine Permissible Spring Deterioration for proper separation by cristian G.rodriquez, ManuelA.Moncada, Emilio E.Dufeu, Mario I razto. Volume 2016, Article ID 4028583
- [12] Dynamics Behavior Research on Variable Linear Vibration Screen with Flexible Screen Face by Changlong Du, KuidongGao, Jianping Li, and HaoJiang, Volume 2014, Article ID 95714
- [13] C. Zhang, One type of large vibrating screen with hyperstatic net-beam structure, China Patent No. 02112809.X(2003).
- [14] W. Heylen, S. Lammens, P. Sas, Modal analysis theory and testing, Prentice Hall Tnc. 1999.
- [15] P. Du, E. Gan, Y. Yu, Principle, model and application of finite element method, National Defence Industry Press, Beijing, 2004.
- [16] R. Wang, H. Yao, S. Xiong, Research on large-scale vibrating screen dynamic parameters based on test modal analysis technology, In: Proceedings of the 5th International Symposium on Test and Measurement, International Academic Publishers, China, 2003.
- [17] F. Ma, Dynamic characteristic analysis of vibrating screen, Coal Mine Machinery, 6 (1996)
- [18] H. Li, Vibration theory and engineering application, Beijing Institute of Technology Press, Beijing, 2006.
- [19] H. Jiao, Y. Zhao, Z. Luo, Parameters optimization of probability screen plane, Journal of China University of Mining & Technology.
- [20] Viperman, J.S., Bauer, E.R., and Babich, D.R., 2007, "Survey of noise in coal preparation plants," Journal of the Acoustical Society of America, Vol. 121 pp. 197-205.
- [21] Jiao H. G., Ma J., Zhao Y. M., Chen L. J. Study on the numerical simulation of batch sieving process. Journal of Coal Science and Engineering, Vol. 12, Issue 2, 2006, p. 80-83.
- [22] F. Wang, L. Liu, Dynamic characteristic analysis of screening machine, Coal Mine Machinery, 10 (1989) 41-43
- [23] F. Zhu, X. Yin, X. Xu, Dynamic characteristic analysis of body of single-pass and double-pass vibrating screen based on FEM, Coal Mine Machinery, 7 (2006) 60-62.