

DEVELOPMENT OF A MODIFIED TESLA TURBINE

Palle Anirudh¹, Shashank D. L.²

¹Graduate, Dept. of Mechanical Engineering, Institute of Aeronautical Engineering, Telangana, India

²Graduate, Dept. of Mechanical Engineering, CVSR College of Engineering, Telangana, India

Abstract - Modern history is adorned with a lot of machines working in modified Rankine or Brayton cycle using the principle of lift producing devices fixed to a rotor system. The inception of a bladeless unit fixed to a rotor which follows the principle of cohesion between the interactive medium of a finite surface and infinite fluid was done by Nikola Tesla in the early parts of the 19th century [12]. Usage of bladeless turbines has a physical advantage of ease of production with less cost making it a cost-efficient process in both mechanical and thermal platforms. Further, interaction of the surface and fluid is subjected to the boundary layer interaction between them. The efficiency of said systems are considerably higher in high RPM's where the surface interaction is conscripted. The power loss occurs due to less surface interaction and significantly lower RPM's.

Key Words: Cohesion, Boundary Layer Interactions, Surface Interactions, Rotor, Bladeless unit

1. INTRODUCTION

Tesla turbine also called as a bladeless turbine or a friction turbine is an alternative to the traditional bladed turbine that uses conventional energy such as fossil fuels, ignition fuels transferring it onto the surface of the blades for power production. Unlike the traditional method, one of a kind innovative idea about the bladeless turbine called as Tesla turbine was put forth by Nikola Tesla through his patent 'The Tesla turbine' in 1913 [12].

Tesla turbine is a distinctive type of turbomachinery which makes use of smooth disks instead of blades. The main principle behind the working of Tesla turbine are the properties of physics: Adhesion and Viscosity. As a contrast to the traditional bladed turbine where the properties of cohesion and adhesion produces an unenviable effect on the efficiency of the turbine, they allow an efficient rotation of the rotor in the Tesla turbine.

As the fluid is passed through a nozzle onto the surface of the disk the first layer of the fluid acts on the surface through viscosity to cause the movement of the rotor called the boundary layer effect and as the rotation takes place the fluid loses energy thereby getting sucked into the exhaust holes. The fluid in this experiment is compressed air sent through the nozzle with high velocity where it swirls onto the dimples present on the surface enabling the disk to rotate as different from the bladed turbine where the fluid is forced to impinge on the profile of the blade.

2. BACKGROUND STUDY

With an increase in the harmful means of energy production and uses of polluting fluids invention of Tesla turbine paved a path towards an effective low energy generation at lower costs and easy manufacturing. Tesla turbine finds its application not only in power generation for household needs but also can be used to tap geothermal energy from underground salt-brine all over the world [9].

In the disk turbine any relative velocity of the fluid for a fixed inlet pressure across the disk causes a viscous drag force that accelerates the rotor increasing the angular speed and decreasing the viscous drag [1]. The torque calculated from the experimentation decreases with increasing angular speed and the output power, efficiency initially increases with increasing angular speed before they reach maximum [1]. Comparison of the performances has been illustrated between the Tesla turbine and the bladeless turbine where it is shown that the performance of one is inversely proportional to other and each has a certain point beyond which a switch over between the two is sought [2].

Investigation on rotor disc surface, performance was done and came to an inference that the disc roughness equal to 0.28 indicated a smooth surface and the roughness equal to below the indicated value did not result in any shear stress generation whereas the maximum power generation were obtained at 3 and 4 bar respectively equal to 42.5W and 71.5W [4]. For more effective momentum transfer from fluid to the disk and efficient rotation of the disks the flow should be laminar [3].

Apart from using compressed air as a fluid working characteristics and systematic flow behavior inside the rotor channels was studied using three organic fluids R404a, R134a, R245fa where they show same efficiency tendency and the performance of R245fa slightly undergoes R134a due to lower critical pressure [5]. Designs for different nozzle types have been made through 3-D plastic rapid prototyping to explore the performance degradation in turbines due to nozzle impedance mismatch and reveal that with increase in the fractional volume of nano particle there is a pressure drop in the radial direction and tangential velocity at any point inside the computational domain tends to increase [6].

Development of a Tesla turbine as a green energy generator for household purposes such as to generate electricity using water supply from tap without significant head loss is an effective way to convert excessive energy

without disrupting the supply of water [7]. In order to attain higher rotor efficiency, the quantity of water flow rate must be made as low as possible that means a greater number of disks and larger rotor [7]. The highest value of efficiency appears when the distance or gap between the disks is made minimum or approximately equal to the double boundary layer thickness [11].

3. FABRICATION AND SET-UP

The bladeless turbine in the current analysis has been slightly modified for increasing the effect of boundary layer and principle of cohesion to work on the dimples of the surface plate. As illustrated in Fig. 2, disks of 10cm diameter with a series of variable depth dimples have been arranged on the periphery of the disk in a slow radial and angular schema against the direction of flow. Six exhaust holes of diameter 4mm have been fabricated around the center of the plate at a distance of 18mm from the center with the help of portable drilling machine.

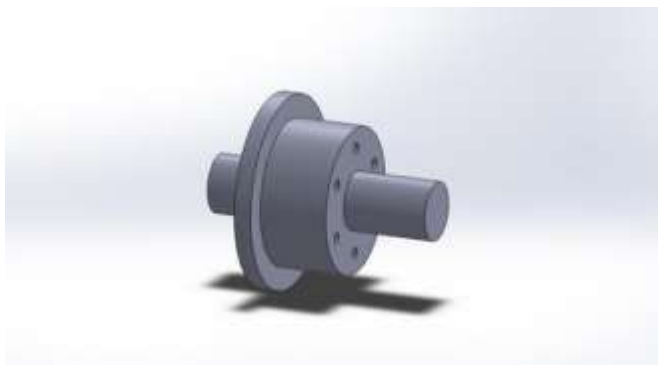

Fig -1: 3-D model of shaft with 6 internally threaded holes.

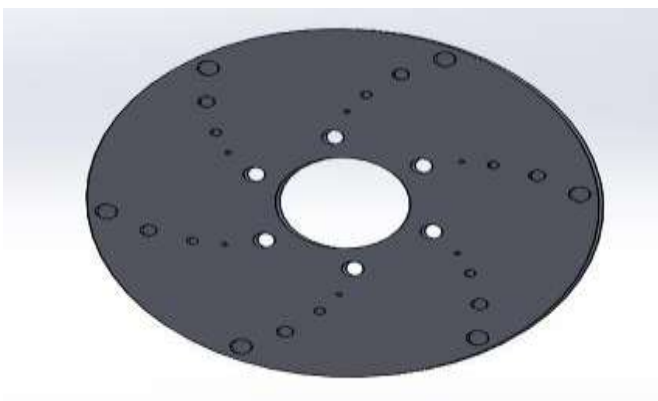

Fig -2: 3-D model of disc with Dimples on the periphery.

Three spacers of 2.2mm thickness are placed between the disks for increasing the cohesion of fluid flow over the space. As shown in Fig. 1, we have managed to design and fabricate a shaft with the steps of variable diameter 10mm, 33mm,

25mm, along the respective lengths with six 3mm internally threaded holes on the side of the shaft for joining the lock plate.

The lock plate is mounted on either side of the shaft for stationary and stable movement of the disks without any causes for vibration. The inlet chamber fixed on the L-shaped cut made on the casing acts as a fluid inlet at high pressure and velocity giving maximum adhesion to the disk surface finally generating a maximum boundary layer. The whole assembly is being held by two 9mm thick acrylic thermoplastic sheet as a casing cover joined to the lock plate by screws.



Fig -3: 3-D model of inlet chamber with fluid inlet at center.



Fig -4: 3-D model of casing with L-shaped cut section.



Fig -5: Fabricated Disc with Dimples.



Fig -6: Fabricated casing with an L- shaped cut section.

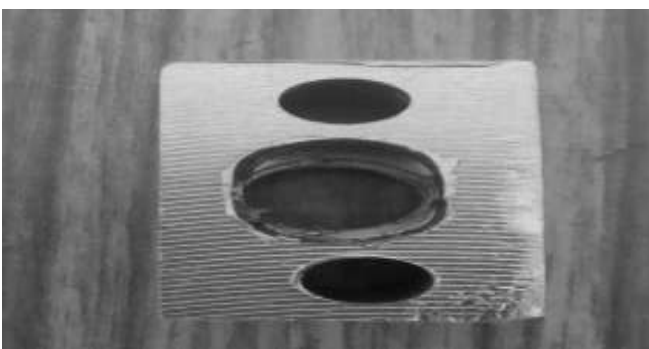

Fig -7: Fabricated Inlet Chamber with fluid inlet at center.

4. PRINCIPLE OF WORKING

The fluid adherence to the wall of the disk caused by the viscosity and turbulence of fluid give rise to shear stress that enables the disks to rotate. Tesla turbine consists of a series of disks arranged in the pattern of an array onto a shaft with the help of bearings that restrict the axial and vertical movement of disks enabling only 2 degrees of freedom that is the rotational movement in clockwise and anticlockwise direction.

All this setup is housed in a casing provided with nozzles that supplies high speed moving fluid and in case of this experiment it is compressed air which is nearly tangential to the rotor. As the fluid flows spirally onto the disks and dimples creating a boundary layer effect due to viscosity and turbulence, it allows the rotor to rotate and further rotating the shaft at higher RPM's and slowly when the fluid had lost its energy it exhausts through the exhaust holes provided on the disks near the shaft.

In this series of actions, the fluid slows down adding energy to the disks causing the motion before it finally spirals through the holes. As the fluid is injected tangentially the component of velocity vector is zero for the reference system corresponding to the disk surface so the only velocity component seen is towards the center of the disk which forces it through the discharge such that it looks like the fluid is spiraling around the disk before it discharges out.

5. RESULTS AND DISCUSSION

Discs with dimples of various sizes on one side of the disc are made and are compared with the results of those without dimples. It has been found that at a nominal inlet pressure of 5 bar the plates with dimples rotate at 13448 RPM whereas the plates without dimples rotate at 12000 RPM which proves that the increment of total surface area of the fluid adhesion by creating dimples during boundary flow has a better effectiveness compared to that of a flat surface plate without any dimples.

Table -1: Table shows the variations in Speed, Power and Torque with respect to pressure for disks with dimples.

PRESSURE	SPEED (RPM)	POWER	TORQUE
1	3500	48.963	0.13359
2	7500	209.842	0.26718
3	9500	398.711	0.40078
4	11400	637.945	0.53438
5	13448	979.301	0.66798

Table -2: Table shows the variations in Speed, Power and Torque with respect to pressure for disks without dimple.

PRESSURE	SPEED (RPM)	POWER	TORQUE
1	4500	62.95	0.13359
2	6000	167.874	0.26718
3	8000	335.756	0.40078
4	10000	559.601	0.53438
5	12000	839.400	0.66798

As a comparison between table 1 and table 2 it is clearly seen that modified disk with the dimples on the surface enhances the speed of rotation as the pressure is increased from 1 bar to 5 bar and so is the power generated that is obtained with dimples at 5 bar pressure and 14000 rpm is more when compared to power generated at 5bar pressure and 12000 rpm. Further clarity of the above deductions can be seen in the graphs below.

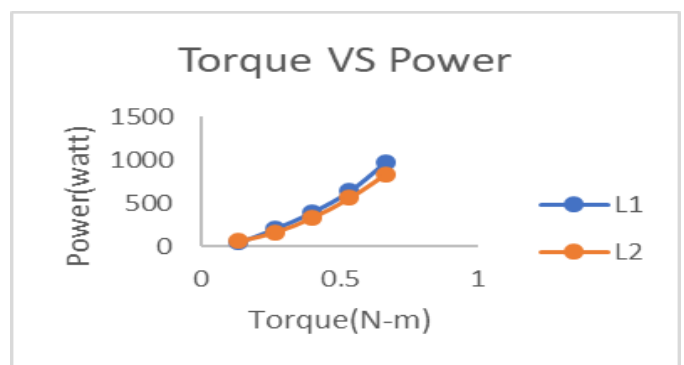

Chart -1: Distribution of Power with respect to Torque as L1 represents line for disk with dimples and L2 represents line for disk without dimples.

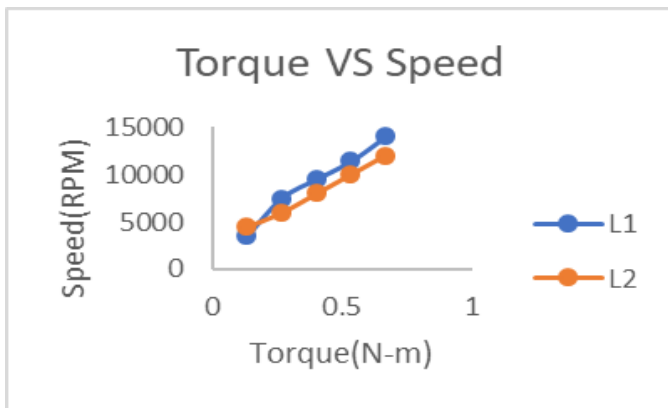

Chart -2: Distribution of Speed with respect to Torque as L1 represents the line for disk with dimples and L2 represents the line for disk without dimples.

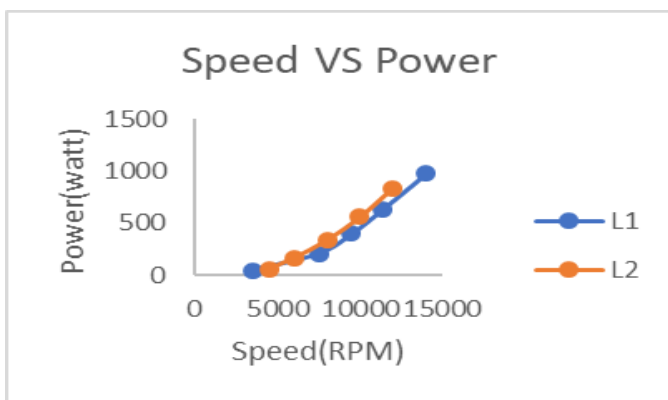

Chart -3: Distribution of Speed with respect to Power as L1 represents the line for disk with dimples and L2 as a line for disk without dimples.

6. CONCLUSION

The experimental analysis and a comparative study on bladeless turbines with and without changes in the profile and topography have been done and the following conclusions have been achieved. The current investigation proposes to promote the boundary interaction between the surface and the fluid by multiple optimized techniques. An experimental setup is also proposed to verify the claim of higher surface interactions. It is estimated that due to higher boundary interaction between surface and fluid the rate of power production might increase as a function of torque produced in the system under variable parameters of pressure, velocity and density. For low inlet pressure, around the range of 1 bar-2 bar (gauge). The bladeless turbine without any enhancements rotate at higher RPM. As the physics transits to compressible flow, the speed and RPM recorded for the enhanced plates are higher compared to that of the non-modified plates. Numerical analysis has been done and the results are validated by cross referring with practical experimental values. It has been found that the theoretical value has an error percentage of around 3-5 % in

comparison with the experimental value, which is normal in nature.

REFERENCES

- [1] Hoya G.P. & Guha A, "The design of a test rig and study of the performance and efficiency of a Tesla disc turbine", Proceedings of the Institution of Mechanical Engineers, Part A: Journal of Power and Energy, Vol. 223, 2009.
- [2] Harikishan Gupta E., Shyam P. Kodali, "Design and Operation of Tesla Turbomachine- A state of the Art Review", International Journal of Advanced Transport Phenomena, Vol. 02, No. 01, pp 7-14, 2013.
- [3] H.S. Couto, J.B.F. Duate & D. Bastos-Netto, "The Tesla Turbine Revisited", Proceedings of 8th Asia-Pacific International Symposium on Combustion and Energy Utilization, Oct 10-12, 2006.
- [4] K. Rusin, W. Wroblewski & M. Strozik, Experimental and Numerical Investigation on Tesla Turbine, Proceedings of XXIII Fluid Mechanics Conference (KKMP 2018)
- [5] L. Ciappi, D. Fiaschi, P. Niknam, L. Talluri "Computational Investigation of Flow Inside a Tesla Turbine Motor", Journal of Energy, 2019, DOI: <https://doi.org/10.1016/j.energy.2019.01.158>.
- [6] Nikhil Bankar, Anil Chavan, Sanket Dhole, Prashant Patunkar "Development of Hybrid Tesla Turbine and Current Trends in Application of Tesla Turbine", International Journal of Technological Research in Engineering, Vol. 3, Issue 7, 2016.
- [7] S.J. Foo, W.C. Tan & M. Shahril, "Development of Tesla Turbine for Green Energy Application", Proceedings of National Conference of Mechanical Engineering Research and Post Graduate Studies (2nd NCMER 2010).
- [8] Tamir A. Emran, Ryan C. Alexander, Chris T. Stallings, Mark A. DeMay, Matthew J. Traum "Method to Accurately Estimate Tesla Turbine Stall Torque for Dynamometer or Generator Load Selection", Proceedings of ASME Early Career Technical Conference, ASME ECTC, 2010, ASME Early Career Technical Journal.
- [9] V. Carey "Assessment of Tesla Turbine Performance for Small Scale Rankine Combined Heat and Power Systems", Journal of Engineering for Gas Turbines and Power 132(12), 2010.
- [10] Warren Rice "An Analytical and Experimental Investigation of Multiple Disk Turbine", Journal of Engineering for Gas Turbines and Power, Vol. 87, Issue 1, 1965.
- [11] Warren Rice "Tesla Turbomachinery", Proceedings of IV International Nikola Tesla Symposium, 1991.
- [12] U.S Patent 1,061,206 (1913).