

Power Allocation Methods for NOMA based Visible Light Communication

Bevara Siva Prasad¹, E.V. Narayana²

¹Department of Electronics and Communication Engineering, University College of Engineering, Kakinada, India

²Assistant Professor, Department of Electronics and Communication Engineering, University College of Engineering, Kakinada, India

Abstract – The design of efficient power allocation methods for Non-orthogonal multiple access (NOMA) technique is to improve achievable sum rate of multiple-input multiple-output (MIMO) based multiuser visible light communication (VLC) systems. In this paper we investigate that NOMA with normalized gain difference power allocation (NGDPA) method improves sum rate up to 47.6%. And compared with gain ratio power allocation (GRPA) method with six and seven users.

Key Words: Multiple-input multiple-output (MIMO), visible light communication (VLC), non-orthogonal multiple access (NOMA)

1. INTRODUCTION:

To increase the number of smart phones, tablet and data-required applications like video streaming, wireless data traffic is expected to increase by a factor of 100. In the year 2010 this requirement was as high as 3 Exabyte's. This requirement is expected to increase 500 Exabyte's by 2020[1]. Therefore future wireless networks require more network capacity. Several 5G technologies such as mm wave and VLC [2] and MIMO etc.. for supporting next generation high speed wireless communication systems require more capacity. VLC is one of the 5G technologies is promising for convenient deployment, natural confidentiality, low energy consumption etc. visible light communication(VLC) is particularly used in electromagnetic sensitive areas such as hospitals, aircraft cabin etc.

As a wireless broadband technology, it is essential that VLC systems can efficiently support multiple users with simultaneous network access [3]. Therefore multiple access techniques are essential in the multiuser VLC systems. Few multiple access techniques are time division multiple access (TDMA), FDMA, CDMA etc.. However these techniques cannot provide sufficient resource reuse. OFDMA is used to VLC systems to reduce required data rate due to the spectrum partitioning. NOMA has been recently proposed for 5G wireless networks due to its superior spectral efficiency [4]. NOMA system uses power domain for multiple users are multiplexed at the transmitter side by superposition coding and successive interference cancellation (SIC), is for multiuser signal separation at the receiver side [5]. Multiple-input and

multiple-output (MIMO) has been widely applied in VLC systems provides additional degree of freedom for future performance improvement. Few power allocation strategies are in MIMO-NOMA based VLC systems, such as fixed power allocation strategy (FPA), post detection [6], hybrid precoding and signal alignment [7] etc. However these methods have high computational complexity.

In this paper we apply normalized gain difference power allocation (NGDPA) method in MIMO-NOMA based VLC systems. It is shown that MIMO-VLC system can be greatly improving achievable sum rate by employing NOMA with the proposed NGDPA method in comparison to NOMA with gain ratio power allocation (GRPA).

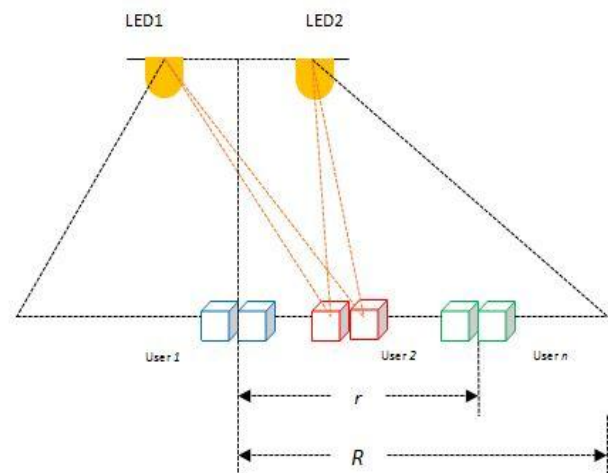

Fig. 1: Illustration of a 4 × 4 MIMO-NOMA-based VLC system with n users.

2. SYSTEM MODEL:

In section 2 we describe the mathematical model of a MIMO-NOMA based multiuser VLC system. Fig 1: shows that indoor 4×4 MIMO-NOMA based VLC system with n users. Each user is equipped with two photodiodes and each user can use entire modulation.

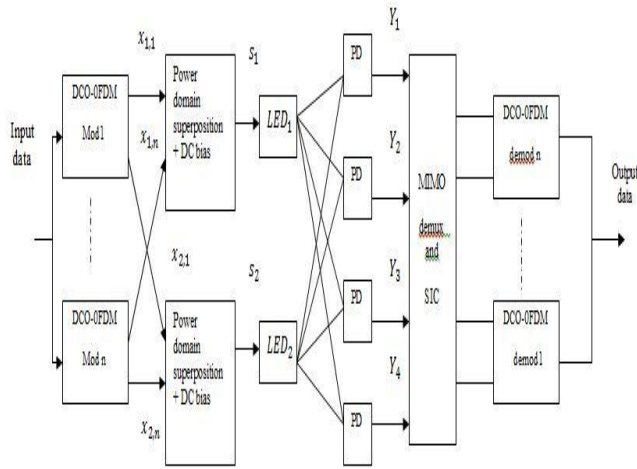

Fig.2. Block diagram of a 4×4 MIMO-NOMA- based VLC system using DCO-OFDM modulation with n users.

DCO-OFDM technique can improve the communication coverage area of indoor MIMO-VLC systems. Fig 2: illustrates the 4×4 MIMO-NOMA-VLC systems with n users. We present a general model of indoor MIMO-VLC systems using DCO-OFDM. The 2×2 MIMO-VLC systems using DCO-OFDM with one pair of LEDs were evaluated [3]. In this work we apply a general indoor 4×4 MIMO-VLC system using DCO-OFDM and it is analytically derived.

Fig 2: shows the 4×4 MIMO-NOMA-VLC system using DCO-OFDM modulation. Let $s_1(t)$ and $s_2(t)$ be the input signals of LED1 and LED2 respectively. After DCO-OFDM modulation power domain super position and DC bias addition. The obtained input signal of the j-th LED ($j=1, 2$), $s_j(t)$, can be represented by

$$s_j(t) = \sum_{n=1}^N \sqrt{\rho_{j,n}} x_{j,n}(t) + I_{DC}, \quad (1)$$

Where $x_{j,n}(t)$ is the signal intended for the n-th ($n=1,2,\dots,N$) user in the j-th LED, $\rho_{j,n}$ is the electrical power allocated for the n-th user in the j-th LED, and I_{DC} is the DC bias for each LED. To ensure a constant over all electrical power P_{elec} for each LED, the following power constraint is imposed.

$$\sum_{n=1}^N \rho_{j,n} = P_{elec} \quad (2)$$

Without loss of generality, let $P_{elec} = 1$.

$$Y_n = \gamma P_{opt} \xi H_n s + K_n, \quad (3)$$

where γ is the responsivity of the PD, P_{opt} is the output optical power of the LED, ξ is the modulation index, H_n is the 4×4 channel matrix of the n-th user, $S = [s_1 s_2]^T$ is the transmitted electrical signal vector where $[\cdot]^T$ is the

transpose operation, and K_n is the additive noise vector. The detailed calculation of the variances of the additive noises can be found in [3].

Assuming each LED in MIMO-VLC system follows a lambertian radiation pattern [2], the LOS optical channel gain between the j-th LED and i-th detector in the detector array of the receiver is calculated by

$$h_{ij} = \sum_{t=1}^L \frac{(m+1)A}{2\pi d_{ijt}^2} \mu \eta \cos^m(\varphi_{ijt}) \cos \theta_{ijt}, \quad (4)$$

where $m = -\ln 2 / \ln(\cos \Psi)$ is the Lambertian emission order; Ψ is the LED's semi-angle at half-power; L is the number of LED chips in one LED; A is the detector's active area; d_{ijt} is the distance between the t-th chip in the j-th LED and the i-th detector; μ and η are the gains of the optical filter and lens, respectively; φ_{ijt} is the emission angle; and θ_{ijt} is the incident angle. The important point is that the optical channel gain becomes zero if the incident light is outside the field of view (FOV) of the receiver. At receiver side to recover the transmitted data, MIMO demultiplexing, and zero-forcing (ZF) using channel inversion is used due to its low complexity. Finally to get the approximate electrical signal vector at the n-th user is obtained by

$$\tilde{S}_n = S + \frac{1}{\gamma P_{opt} \xi} H_n^{-1} K_n, \quad (5)$$

Where H_n^{-1} is the inverse of H_n . Later successive interference cancellation (SIC) is applied with respect to each LED at each user. To perform SIC at receiver side based on decoding order of the users with respect to each LED should be first determined. In this work we use the sum of the optical channel gains of each user with respect to each LED instead of individual optical channel gains to sort the users, without loss of generality, to sort the users according to their sum of optical channel gains in the decreasing order as follows

$$h_{1j,1} + h_{2j,1} > h_{1j,2} + h_{2j,2} > \dots > h_{1j,n} + h_{2j,n}, \quad (6)$$

The decoding order with respect to the j-th LED is

$$D_{j,1} < D_{j,2} < \dots < D_{j,n}. \quad (7)$$

Finally we get the data for six and seven users are obtained via DCO-OFDM demodulation.

3. POWER ALLOCATION METHODS:

In this section two types of power allocation methods are considered. One is gain ratio power allocation (GRPA) and the other one is normalized gain difference power

allocation (NGDPA). As illustrated in the following two subsections respectively.

3.1 GAIN RATIO POWER ALLOCATION (GRPA):

It is low complexity power allocation method is ensure to evaluate the achievable sum rate of MIMO-NOMA based VLC systems [8]. In GRPA, power allocation based on optical channel gain of each user. In this work we use sum optical channel gain instead of individual channel gain, the GRPA method can be generalised for MIMO-NOMA based VLC systems. In the 4x4 MIMO-NOMA-VLC system using GRPA, according to the decoding order in (7), the relationship between the electrical powers allocated to user n and user $n + 1$ in the j -th LED is given by

$$\rho_{j,n} = \left(\frac{h_{1j,n+1} + h_{2j,n+1}}{h_{1j,1} + h_{2j,1}} \right)^{n+1} \rho_{j,n+1} \quad (8)$$

3.2 NORMALIZED GAIN DIFFERENCE POWER ALLOCATION (NGDPA):

NGDPA is proposed for further improvement of the achievable sum rate of MIMO-NOMA based VLC system. In NGDPA power allocation depends on optical channel gain difference. Finally the power allocated to users n and user $n+1$ in the j -th LED have the following relationship

$$\rho_{j,n} = \left(\frac{h_{1j,1} + h_{2j,1} - h_{1j,n+1} - h_{2j,n+1}}{h_{1j,1} + h_{2j,1}} \right)^n \rho_{j,n+1} \quad (9)$$

We observed from (9), optical channel gain difference is used instead of sum of optical channel gains as in (8) then the power is reduced from $n+1$ to n .

TABLE-1 SIMULATION PARAMETERS

Parameter	Value
Vertical distance between the LED and users	2.15
LED semi angle Ψ	60°
Spacing between LEDS	1m
Optical power P_{elec}	10W
Modulation index	0.5
Signal bandwidth B	10MHZ
PD active area A	1 cm ²
PD responsivity γ	0.5A/W
Optical filter gain μ	0.9
Optical lens gain η	2.5
Total number of users n	7

4. SIMULATION RESULTS:

In this section we evaluate the performance of a 4x4 MIMO-NOMA based VLC systems with seven users. We set the normalised offset of user n with respect to user 1 as $\frac{r}{R}$.

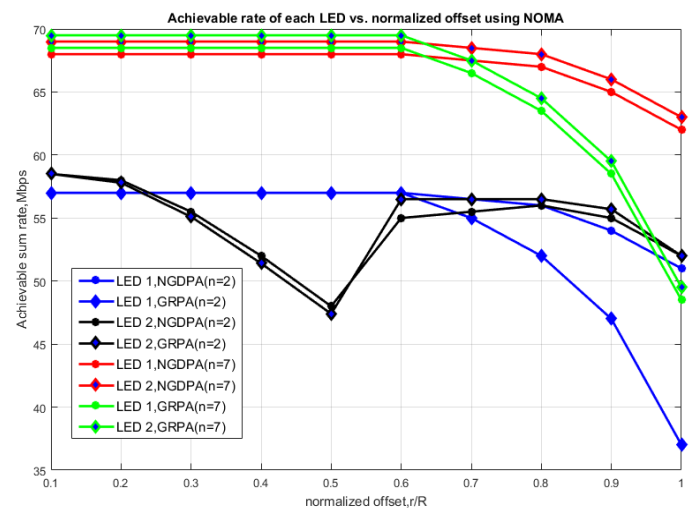

Fig.3. Achievable rate of each LED vs. normalized offset using NOMA with seven users ($n = 7$).

Fig3: shows the achievable rate of each LED in 4x4 MIMO-NOMA based VLC systems with seven users. It shows that achievable rate of LED1 is 68.8 Mbit/s when $0.1 \leq \frac{r}{R} \leq 0.6$ for GRPA and for NGDPA is 68.6 Mbit/s. when further increase of $\frac{r}{R}$, the achievable rate of LED1 using GRPA is greatly reduced to 49.6 Mbit/s at $\frac{r}{R} = 1$. By using NGDPA method the achievable rate is slightly reduced with the further increase of $\frac{r}{R}$ and the achievable rate is 64.1 Mbit/s at $\frac{r}{R} = 1$. as can also be seen the achievable rate of LED2 is almost same at different $\frac{r}{R}$ values for both GRPA and NGDPA methods. Further increase of $\frac{r}{R}$ that is at the end of users the achievable rate of LED2 using GRPA is greatly reduced and it is almost 49.9 Mbit/s at $\frac{r}{R} = 1$. In contrast the achievable rate of LED2 using NGDPA method is 65 Mbit/s at $\frac{r}{R} = 1$. Hence the performance of GRPA method is poor at far-end users.

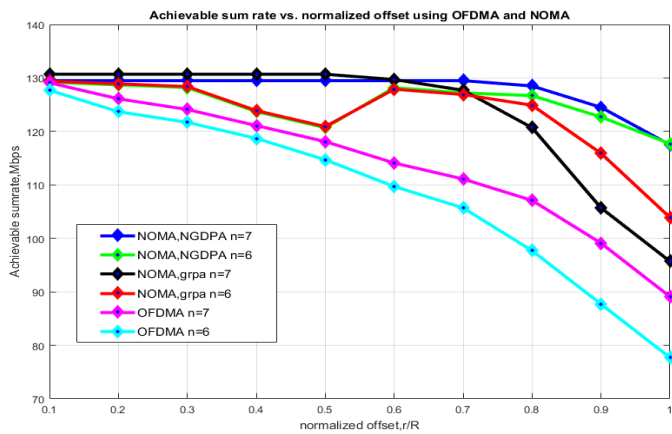

Fig.4. Achievable sum rate vs. normalized offset using OFDMA and NOMA.

Fig.4 shows the comparison of achievable sum rate in 4×4 MIMO-VLC system employing OFDMA and NOMA. As we can see that the achievable sum rate using OFDMA is continuously reduced with increase of $\frac{r}{R}$. By using NOMA with GRPA method the sum rate fluctuates with the increase of $\frac{r}{R}$. A fast decrease occurs when $\frac{r}{R} > 0.6$, indicating that NOMA with GRPA suffers from significant sum rate loss when $\frac{r}{R}$ becomes relatively large. When NOMA with NGDPA method is used the performance of achievable sum rate is improved compared with NOMA with GRPA method.

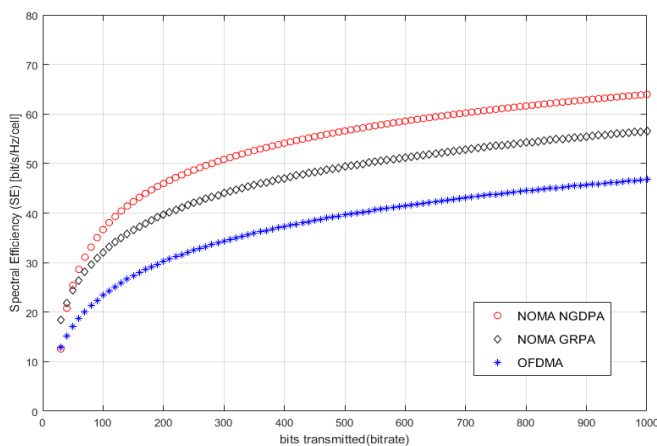

Fig.5. Spectral efficiency vs bit rate using OFDMA and NOMA

Fig.5 shows the comparison of spectral efficiency in VLC systems employing OFDMA and NOMA. As we can see that the bit rate employing OFDMA is reduced due to spectrum partitioning and hence the spectral efficiency of NOMA will be greater than OFDMA and it shown in the above fig.5.

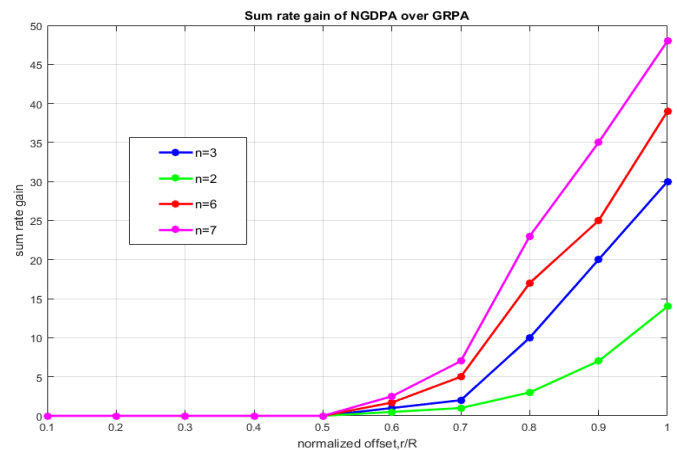

Fig. 6. Sum rate gain of NGDPA over GRPA in NOMA vs. Normalized offset.

Fig.6: shows the sum rate gain of NGDPA over GRPA versus $\frac{r}{R}$. Here we can see that the sum rate gain using NOMA with NGDPA is more efficient comparing NOMA with GRPA especially at far end of users. For example, when $\frac{r}{R} = 1$ that is user n is located at the edge of the system coverage the sum rate gains are 39.3% and 47.6% for n=6 and n=7 respectively.

5. CONCLUSION:

In this paper NOMA with power allocation methods are designed to allocate more power to users experiencing poor channel conditions. It is intended to enhance the data rate of edge users and alleviate the near-far effect without degrading the performance of central users. The simulation results shows that in an indoor 4×4 MIMO-VLC systems, NOMA with NGDPA method is improved sum rate than NOMA with GRPA method. In 4×4 MIMO based VLC systems using NOMA with NGDPA achieves sum rate up to 47.6% with seven users. Therefore, the sum rate of NOMA with NGDPA over GRPA method is more significant with more users in the VLC systems.

REFERENCES

- [1] J. G. Andrews, S. Buzzi, W. Choi, S. Hanly, A. Lozano, A. C. K. Soong, and J. C. Zhang, "What Will 5G Be?" IEEE J. Sel. Areas Commun., vol. 32, no. 6, pp. 1065–1082, Jun. 2014.
- [2] S. Dimitrov and H. Haas, Principles of LED Light Communications: Towards Networked Li-Fi. Cambridge University Press, 2015.
- [3] H. Haas, L. Yin, Y. Wang, and C. Chen, "What is LiFi?" J. Lightw. Technol., vol. 34, no. 6, pp. 1533–1544, Mar. 2016.
- [4] L. Dai, B. Wang, Y. Yuan, S. Han, C.-L. I, and Z. Wang, "Non-orthogonal multiple access for 5G: Solutions,

challenges, opportunities, and future research trends,” *IEEE Commun. Mag.*, vol. 53, no. 9, pp. 74–81, Sep. 2015.

[5] Z. Ding, Z. Yang, P. Fan, and H. V. Poor, “On the performance of non-orthogonal multiple access in 5G systems with randomly deployed users,” *IEEE Signal Process. Lett.*, vol. 21, no. 12, pp. 1501–1505, Dec. 2014.

[6] Z. Ding, F. Adachi, and H. V. Poor, “The application of MIMO to non orthogonal multiple access,” *IEEE Trans. Wireless Commun.*, vol. 15, no. 1, pp. 537–552, Jan. 2016.

[7] Z. Ding, R. Schober, and H. V. Poor, “A general MIMO framework for NOMA downlink and uplink transmission based on signal alignment,” *IEEE Trans. Wireless Commun.*, vol. 15, no. 6, pp. 4438–4454, Jun. 2016.

[8] L. Yin, W. O. Popoola, X. Wu, and H. Haas, “Performance evaluation of non-orthogonal multiple access in visible light communication” *IEEE Trans. Commun.*, vol.64,no.12 pp.5162-5175, Dec.2016.