

A RESEARCH PAPER ON DESIGN AND EXPERIMENTATION ON CONTINUOUS LOOP DEMULSIFIER

Divij Gupta¹, Ketan Singhvi²

^{1,2}B.E. Mechanical

Abstract - This paper explains the working of a Demulsifier used to separate water from crude oil. This separation is of utmost importance and economic relevance affecting the quality of crude oil. The water present in crude oil enhances corrosion in refineries, reduces quality of crude oil and its by-products, and catalysis occurs. Hence we have developed a practical and low cost model of a demulsifier that increases the demulsification rate and improves the oil quality.

Key Words: demulsifier, crude oil, demulsification, catalysis

1. INTRODUCTION

India imports more than 82% of its oil needs. Oil water separators or demulsifiers are hence of great importance today. Water molecules induced during extraction of crude oil from 4000 m below sea level, form an emulsion with the oil that corrodes the process equipment, drastically reduces oil quality and may render it poisonous. Therefore it is necessary to keep the water below 0.3% by volume and salt below 10 lbs PTB (per thousand barrels). Other separation processes like gravity separation, chemical demulsification, centrifugal separation etc. used currently either have high maintenance and running costs or low production rates.

Hence we are developing an electrostatic separator that is continuous. It will maintain the industry standards of crude oil. Also demulsifier will potentially reduce the cost of production of petroleum products. High voltage electricity is used to induce opposite dipole charges in small water droplets and coalesce the water droplets so that they fall under the action of gravity

2. LITERATURE REVIEW

In [1], the researchers showed that the dependency of water drop in emulsion (water and oil) in conductivity for specific phase of medium. The researchers used two method to do this experiment, one was cone-dimple method and other was cone-spray method. In the experiment of cone-dimple method was performed under the silicon oil and this was done by increasing its conductivity and inserting peperazine and D130. But the reason behind performing this experiment was difficult to explain as per the researchers, but they assumed that this can be due to high conductivity of medium to form the jet, unlike the dielectric medium. Thus, they concluded that this happen because the charge travel between the high conductivity medium and because of this it generates the tangential stress at the interface which results in formation of jet.

From this experiment that have observed that the coalescence of oil in a medium, cone dimple method is dielectric in medium conductivity due to properties of crude oil, and concluded that how electric field depends on coalescence method that affect the construction of parts like desalters and dehydrators and separation of water.

In [2], the authors shows that how the water drops id separated due to electrocoalescence process. This process can get more efficient by different methods like applying gravity, improvement in Stokeslet interaction in hydrodynamics, applying high electrostatics, electric field which is dependable that can be accomplished by high conductivity of drop. Hence, the authors finally concluded that in demulsifier process separation of drop can be achieved by verified experimental data.

In [3], the researchers checked the coalescence of uniform and non-uniform electric field in two mixture (water-in-oil mixture and oil-in-oil mixture). By the data the researchers observed that in water-in-oil mixture, the uniform and symmetric non-uniform electric is less advantages than the asymmetric non-uniform electric field and in case of oil-in-oil mixture it was completely opposite. Hence, the researchers concluded that for optimum results the electrode should be coated so that they can produce more asymmetric electric field and dependency of efficient electrode is on properties of dispersed and continuous phase.

In [4], the researchers shows that the angle between two drops should be less than 54.7° and 125.3° so that the electric field to be largest. From the experimental data they observed that at 0° angle the surface of drops can go under deformation that are facing each other. From this experiment researchers also understood that 2-D electrode can be designed by inducing electric field that is perpendicular between the imaginary lines drawn from center of two drops. The experimental data showed the researchers that the drop will vibrate when the electric field is same as the applied pulsed frequency. If the frequency is not

same that the drop will have small magnitude of vibration because this depends on continuous liquid phase. Hence, by these experimental data researchers concluded that electric field is necessary for water droplets separation and also shows the better design of demulsifier that can be developed so that it becomes more efficient.

3. MATERIAL AND COMPONENTS

3.1 Emulsion feeder:

A hollow tube with holes is used to properly distribute the flow of emulsion in the Demulsifier vessel. This ensures that separation starts as soon as emulsion leaves the emulsion feeder, since due to a uniform flow across the vessel length more emulsion is in contact with the electric field.

Material used: SS304

Dimensions: OD - 12 mm

ID - 7 mm

Orifice diameter - 1 mm

Length - 400 mm



Fig -1: Emulsion Feeder

3.2 Collector:

A hollow tube with holes with a pipe in the middle is used to collect pure oil after separation. Since oil is less dense it enters the collector from underneath through the holes and exits through the pipe due to pressure exerted on it.

Material used: SS304

Dimensions: OD- 16 mm

ID- 10 mm

Orifice diameter- 6 mm

Pipe diameter: OD- 8 mm

ID- 6 mm



Fig -2: Collector

3.3 Bi cylindrical rod Electrodes:

Two rod shaped Electrodes are used to create a uniformly distributed electrostatic field in the entire vessel. This cylindrical rod allows for a much strong and uniform electrostatic field. The voltage applied depends on the distance between the surfaces of these electrodes, which is to be roughly 1 kV/cm or more.

Material used: SS304

Dimensions: Main Rod Diameter- 10 mm

Length- 340 mm cylindrical

rod

Diameter- 6 mm Length-

120 mm

Pitch of Cylindrical rod- 20 mm

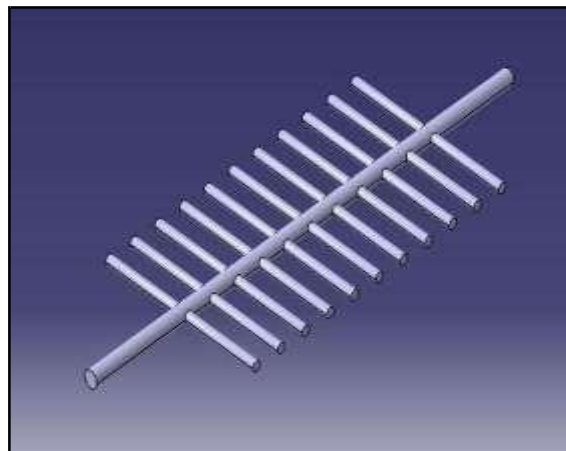

Fig -3: Bi cylindrical rod Electrodes

3.4 Pump:

A reciprocating plunger pump (dosing) is used to pump the emulsion in the vessel via the emulsion feeder. Specifications:

Company- Positive Metering Pumps Pvt. Ltd.

Capacity- 0-80 lph (variable flow rate)

Pressure- 10 kg/cm²

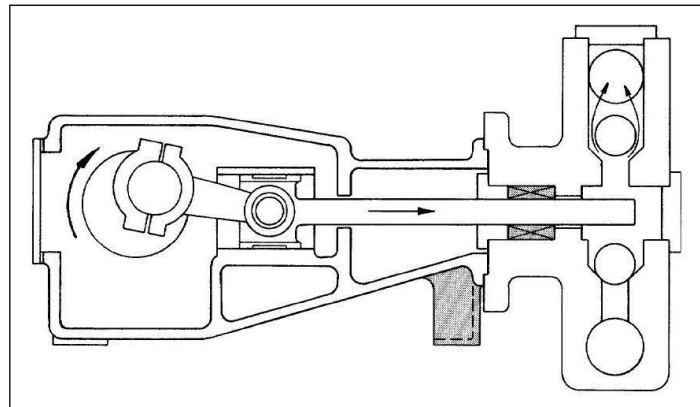

Fig -4: Pump

3.5 Demulsifier Vessel:

An acrylic vessel is used to mount all the components of the demulsifier and inspect the separation of the two liquids. Components are mounted in the following order from top to bottom- Collector, Electrode, Emulsion feeder, Electrode. In this vessel the actual coalescence and separation occurs.

Material used: Acrylic

Dimensions: Outer Diameter- 190 mm

Thickness- 5 mm

PCD for fasteners- 250 mm

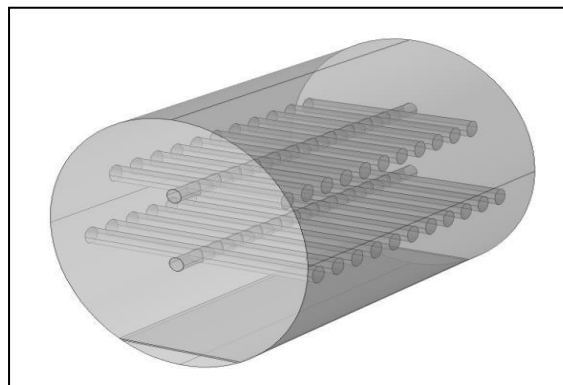

Fig -5: Geometry of Demulsifier

3.6 High Voltage Amplifier:

A High Voltage Amplifier is used to achieve desired voltage at the desired frequency. The voltage gain in the amplifier used is 2000.

4. WORKING PRINCIPLE

A Demulsifier works on the principle of electrophoresis. Due to the uniform electrostatic field between two electrodes, an electric dipole charge is induced in the micro droplets present in the crude oil resulting in a charge density. The polarity of the dipole charge developed in any droplet depends on the proximity of that droplet to the electrode. The droplets near the positive electrode develop a positive dipole and droplets near the negative electrode develop a negative dipole. The opposite dipole charges and charge density between carrying fluid and micro-droplets act on droplets causing them to move and coalesce to form large drops of water regimenting quickly under the due to gravity. This water is then drained via the drain valve. The separation percentage of water and its residence time depends upon various factors like intensity of electric field, flow rate of emulsion, electronic configuration etc.

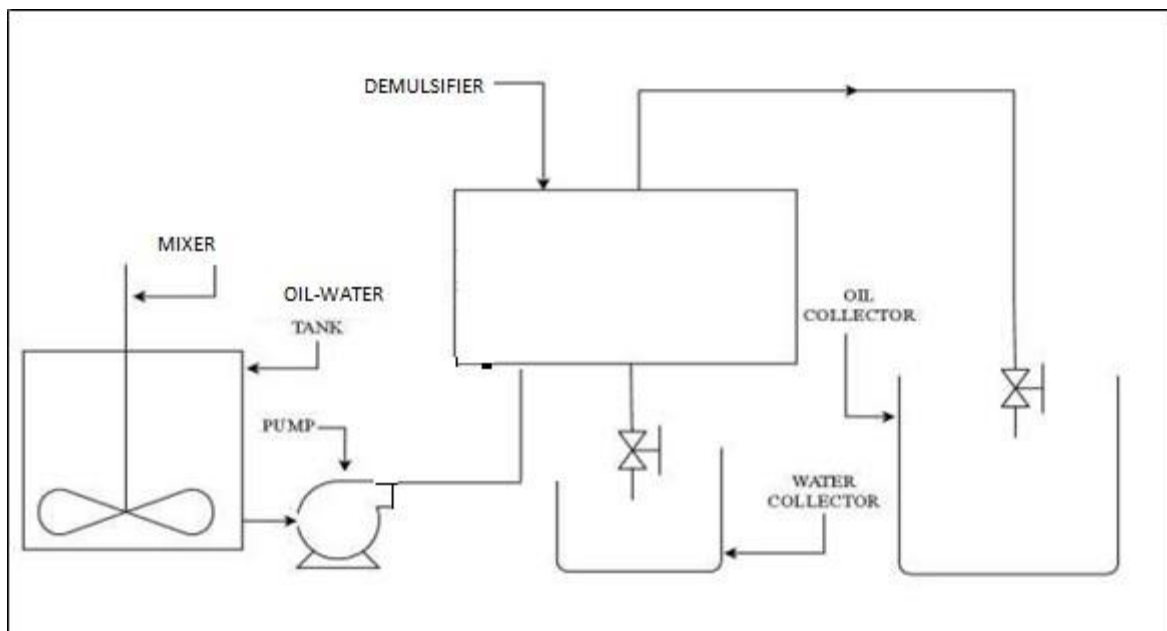

Fig -6: Diagrammatic Representation of Demulsifier

5. WORKING OF CONTINUOUS LOOP DEMULSIFIER

In this project we have built a model of Continuous Loop Demulsifier for experimentation and simulation purposes. The oil-water emulsion is prepared by mixing both liquids in an emulsion tank and continuous stirring. This emulsion is pumped using a metered dosing pump in the demulsifier vessel via the emulsion feeder. The two phase emulsion gets separated in this vessel due to the electrostatic field. The higher density water is drained through the drain valve in a water collector. While the lower density oil is collected in a separate tank via the collector.

6. EXPERIMENT SPECIFICATIONS

- 1) Emulsion contents: 9000 mL oil (Sunflower Oil)
1160 mL water (Milli-Q Water)
- 2) Electric Configuration- Electrodes live and vessel grounded.
- 3) Pump used- Reciprocating Pump: Capacity - 0-100 Lph
Pressure- 10 kg/cm²
- 4) Setting of Amplifier: Voltage- 5000 V AC
Frequency- 50 Hz

7. METHODOLOGY OF EXPERIMENTATION

1) Preparation of Emulsion:

An oil-in-water emulsion is prepared by mixing 90% oil and 10% water. This mixture is homogenized using a high-speed mixer for 3 minutes. A white homogenous emulsion is formed.

Emulsion contents: 9000 mL oil

1000 mL water

2) Assembly and Preparation of Setup:

The Demulsifier setup is assembled according to the required electric configuration to be used.

Voltage Applied- 5000 V AC

Frequency- 50 Hz

- 3) The emulsion is pumped into the coalescer vessel at a rate of 10 lph and the stopwatch is started. The experiments is conducted for about 30 minutes.
- 4) The Cylindrical rod Electrodes are supplied with 5000 V of electricity using a high voltage amplifier.
- 5) During the experiment as separation occurs, the oil is collected in an oil tank. Within regular intervals of 3 minutes samples are collected in numbered sampling tubes.
- 6) The collected samples are then tested for water percent by volume using Karl Fischer's titration.
- 7) Karl Fischer's Titration:
- 8) The percentages of water in the oil samples are noted and plotted against time.

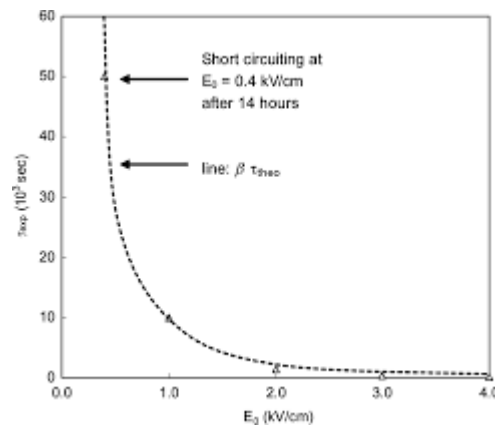

Fig -7: Performance Characteristics of a Demulsifier

8. RESULTS

8.1 Observations:

- 1) The water droplets start to coalesce as soon as the emulsion enters the electric field.
- 2) The droplets coalesced and form bigger drops.
- 3) These drops fall under the action of gravity and water gets collected in the lower part of the vessel due to higher density.
- 4) Pure unadulterated oil is collected through the collector in a separate tank.

5) Total water used-1160 mL

Total water separated-1100 mL

Percentage of water separated~95%

8.2 Results of Karl Fischer's Titration:

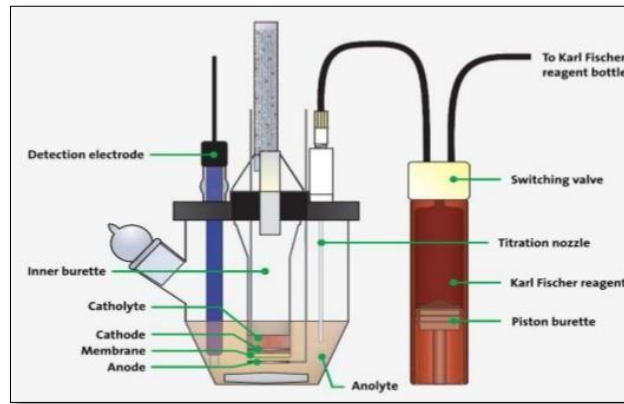

Fig -8: Karl Fischer's Titration Setup

Sample Number	Weight (mg)	Volume Displaced (ml)	% Moisture by weight
1	127.07	0.294	1.1744
2	129.60	0.289	1.1358
3	121.69	0.287	1.2013
4	132.46	0.261	1.0039
5	121.54	0.457	1.9128
6	131.19	0.180	0.6964
7	144.10	0.284	1.0003
8	136.78	0.010	0.0371
9	167.61	0.294	0.8903
10	130.95	0.292	1.1318

Table 1: Karl Fischer's Titration Result

- 1) Maximum percentage of moisture- 1.9128%
- 2) Minimum percentage of moisture-0.0371%
- 3) Average percentage of moisture- 1.0184%

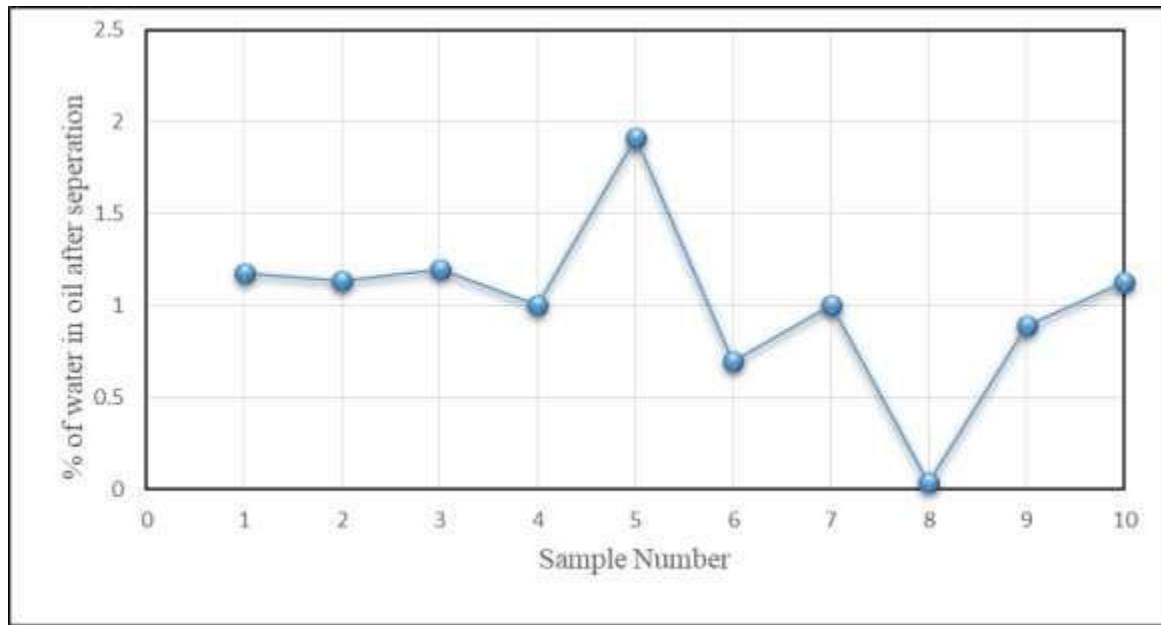

Chart -1: Sample number v/s percentage separation of water

9. CONCLUSIONS

- 1) The experimental setup successfully demulsifies the water-in-oil emulsion in a continuous loop.
- 2) Since there was no sparking in the setup, the electric field of 1 kV/cm is apt for electrocoalescence.
- 3) Satisfactory percentages of separation were achieved during the experimentation.

10. FUTURE SCOPE

- 1) Further experiments are to be conducted to find:
 - a) Variation of percentage of coalescence with change in frequency.
 - b) Dependence of separation and quality of oil on the flow rate of emulsion.
 - c) Residence time, position of emulsion feeder, electric field dependency on percentage water cut in emulsion.
- 2) Further analysis on optimum size of water droplets for coalescence to occur.
- 3) Designing of experiments to reduce sparking in coalesce due to water chain formation.
- 4) Design and development of systems with higher flow rate and lower residence time for faster production rate.

11. REFERENCES

1. Drop-drop coalescence in an electric field: the effect of applied electric field and electrode geometry." Prof. John S. Eow, Mojtaba Ghadiri, Date of Publications: 23 January 2003, Volume 219,
2. "The Electrocoalescers' technology: Advances, strengths and limitations, for crude oil separation". Simone Less, Regis Vilagines, Saudi Aramco, Research and Development Center, Dhahran, Saudi Arabia
3. Electrostatic and hydrodynamic separation of aqueous drops in a flowing viscous oil John S. Eow, Mojtaba Ghadiri, Adel O. Sharif. Department of Chemical and Process Engineering, University of Surrey, GU2 7XH Guildford, UK.
4. Electrostatic enhancement of coalescence of water droplets in oil: a review of the current understanding John S. Eowa, Mojtaba Ghadiri, Adel O. Sharif, Trevor J. Williams. Department of Chemical and Process Engineering, University of Surrey, Surrey, Guildford GU2 7XH, UK b Electrical Power Engineering Research Group, Department of Electronics and Computer Science, University of Southampton, Southampton SO17 1BJ, UK
5. https://en.m.wikipedia.org/wiki/Oil_and_gas_industry_in_India
6. http://pumps.org/Pump_Fundamentals_Positive_Displacement_Pumps.aspx
7. <https://www.slideshare.net/mobile/varinderkumar62/karl-fischer-titrationprincipleapparatus-titration-typesendpoint-detection>