

Air Pollution Monitoring System using the Internet of Things

Shivam Sharma¹, Nishu Soni², Shubhangi Sharma³

^{1,2}Dept. of CSE, Bharat Institute of Technology, Meerut, Uttar Pradesh, India

³Assistant Professor, Dept. of CSE, Bharat Institute of Technology, Meerut, Uttar Pradesh, India

Abstract - With the increase in population, pollution is increasing day by day due to industrialization, urbanization, and vehicles use. All these factors can affect human health directly or indirectly by respiration, intake of water, eating food and in many other ways. Air pollution monitoring system using the Internet of Things is used to control the quality of air over web server with the help of internet. When the quality of air reaches lower to a certain level, it will activate an alarm. It means when there is an increase in the level of harmful gases like NH₃, CO₂, NO_x, alcohol, smoke, benzene, etc. It shows the quality of air in PPM (part per million) on the LCD as well as on the server so that the pollution in the air can be monitored.

For monitoring the air quality, this system uses MQ135 and MQ6 sensors which can detect the most harmful gases and also measure their quantity accurately. The aim of this paper is to plan and execute an air quality monitoring device using the Internet of Thing which is also known as IoT for controlling air pollution and enhance the quality of air. This system measures the real-time air quality index, temperature, humidity which is displayed on a website with the help of internet. With implementing of this system, aware can be given to the people on the website to wear the anti-pollutant mask, they can change their track or pathway while traveling through any mode of transportation where the pollution in the air is very high. It provides consciousness among people about the level of air pollution and what is the way to reduce it from increasing.

Key Words: Internet of Things, Air Pollution, Sensors, Monitoring System, Arduino, MQ135

I. INTRODUCTION

The main aim of designing this is that increasing air pollution is a global issue. The problem related to health is growing at a faster rate because an increasing number of vehicles and industries produces a large amount of harmful gaseous pollutants. Due to an increase in air pollution, many diseases like heart disease, bronchitis, heart disease, pneumonia, lung problem, also irritation in the throat, eyes, and nose, etc. As per the observation, with the increase in the air pollution in worldwide, approximately 50,000 to 100,000 early or untimely deaths per year happen in the United State of America separately and about 300,000 to 3,000,000 deaths per year occur in European Union [1].

As we all know that various types of harmful emissions known as primary pollutants are emitted in the environment and after the certain chemical reaction, results in the formation of new types of pollutants which is basically known as a secondary pollutant. Many examples are seen in day to day life, according to the Intergovernmental Panel on Climate Change (IPCC) which come under the Fifth Assessment Report, about all climate-changing pollutants either it directly or indirectly (also by including the secondary pollutants which are present in the atmosphere) cause the severe form of health problem in the living beings [2]. Most of the citizens or people spend 90% of their daily time in the indoor atmosphere [3]. In the recent period of 10 years, the quality of air of outdoor area in the developed countries improved but indoor air quality decreases in the same time because of the some of the factors like decrease in ventilation, reserving of energy and also due to the new appliances used for the household purpose [4].

As we all know that the Internet of Things becomes very popular in the modern present era. In the air, there are enough amount of harmful gases like CO₂, benzene, smoke, alcohol, NH₃, NO_x, etc. With the help of this system, we can monitor the quality of air via a web server and ring the alarm where pollution goes beyond the threshold condition. It shows the quality of air in ppm on LCD module and on the webpage where it can be controlled very easily. Mostly in houses, LPG sensor can be used. It also shows the humidity and temperature. IoT based system can be used anywhere but mostly used in industries and houses where harmful gases are found and give an alert message when the system reaches its threshold value.

II. RESEARCH CONTRIBUTION

Using the analysis of the system, there are possible outcomes that can be achieved are the following:

- For some extent, we can reduce pollution when there is a rise in the number of harmful gases in the air.
- For some extent, we also try to reduce the cost which is affordable to everyone in this paper while the cost of the other system is very high in the present scenario.
- In the current technology, the system often using a snapshot of the project, but in our new technology, it will work in continuous live basis.

- D. As we all know that most of the system is using only by the expert person who has knowledge about the existing system but in this project, it is easy to use to each and every person.
- E. Many projects totally dependent on lab analysis but in this new technology, it is basically real-time without using lab analysis.
- F. In the current system, it established QA protocols, but in this new technology, it provides QA protocol gaps.
- G. We have to reduce industrialization and urbanization.
- H. Instead of using harmful fuel in the vehicles, we prefer the use of CNG which is not harmful.
- I. In the old technology, the government, industrialist, researchers have only the right to operate the system. But, in this new technology including these, the system has operated by communities and individuals, commercial groups, etc.

We people already know that in the former technology, data stored and describe only on government websites, but in this coming technology, data stored, shared, accessed can be done not only from government websites but also from non-government websites.

III. EXISTING MODEL

- A. Nowadays there are large varieties of different air monitoring and alarming devices are available in the market. Due to the massive size, high weight, and expensiveness constitute the failure of conventional monitoring system which leads to the insufficient deployment of the monitoring stations. As we all know that air pollution in metropolitan cities is due to human activities like construction works, locations with traffic jams have the worst air quality than average.
- B. By the help of air pollution monitoring system using IoT, the quality of air can be detected on the webserver using the internet by triggering the alarm when it crosses the certain threshold value means when certain harmful gases like CO₂, smoke, benzene, etc. are present in the atmosphere. The system can also be detected and monitored the temperature and humidity.
- C. Using the MQ6 sensor and MQ135 sensor for the purpose of monitoring the air quality, this system can detect the injurious gases and measures its amount precisely. It can also display the pollution level from any place using the PC and smartphones. The IoT based system can be installed anywhere and when the quality of air goes beyond a certain level, it triggers

the alarm and send message to the receiver so that the air quality can be controlled.



Fig -1: Planning Management for Air Quality

IV. PROBLEM STATEMENT

During last some decades, due to progress in urbanization and civilization, there is a wide increase in the industries which causes pollution, burning of waste materials in open space and heavy amount of dump materials produced at construction sites, substantial decrement in number of forests and vehicles (specially diesel vehicles) on roads which increase in health hazards related to pollution. Hence, it is necessary to monitor and control air pollution and reduce the hazardous effect of air pollution which causes the health-related problem.

This proposed system introduced advanced techniques to display air quality with the help of new technologies. Harmful pollutants present in the environment like CO₂, CO, availability of smoke, alcohol, LPG, humidity, and temperature can be monitored by some technology such as GSM, Bluetooth, Wi-Fi, Wireless Sensor Network, etc.

1. AIR QUALITY PARAMETERS

The main parameter considered in this project includes:

1.1. Carbon Dioxide (CO₂): It is an odorless, colorless and non-combustible gas. CO₂ is the essential gas for life on the planet because it is the only gas responsible for photosynthesis in which solar energy is converted into chemical energy. The main reason behind the increase in the concentration of CO₂ is the burning of fossil fuels. Furthermore, this is already examined under the type of suffocate gas [19]. It experiments that when the body remains without oxygen for more than 4-5 minutes it can cause severe brain damage or may also lead to the death of the individual. Outside air can be fulfilled the requirement of CO₂ and according to the standard, it should be less than 1000ppm [20]. Generally, it is found that CO₂ present in the outdoor atmosphere is less than 350ppm.

1.2. Carbon Monoxide (CO): It is highly poisonous, colorless and odorless gas. This is emitted only when there is no complete ignition of fuel and release in the atmosphere [1]. When it is released into the atmosphere, it is mixed with the hemoglobin which is present in the blood by respiration, it forms carboxyhemoglobin (HbCo) which results in a decrease in the oxygen-carrying capacity of the blood which causes deficiency of oxygen in the tissues that are hypoxia. With the release of 100ppm or more amount of CO in the air is harmful to the health of humans [16]. The problems like depression, confusion and memory loss can be caused by continuous exposure of carbon monoxide in the atmosphere. The conversion of carboxyhemoglobin to hemoglobin is done but the act of process is very slow due to the complexity of the molecule HbCo. The treatment of CO poisoning is although arguable or disputable but whether or not it provides necessary results, oxygen therapy is provided to the patient so that they may be recovered from the problem [17]. By using the non-rebreathable mask, about half of the carbon monoxide gas can be reduced 1/4th times i.e. from 320 minutes to 80 minutes in presence of normal air by handling the amount of oxygen [18].

1.3 Sulphur Dioxide (SO₂): SO₂ is a colorless gas that can be detected by unique odor and taste. It also due to the burning of fossil fuel. If the concentration of SO₂ goes beyond a certain level it may cause respiratory problems.

1.4 Nitrogen Dioxide (NO₂): It is a brownish gas and can be easily detected by its odor, highly corrosive and highly oxidant nature. Likewise SO₂, a higher amount of NO₂ in air will leads to an increase in respiratory diseases.

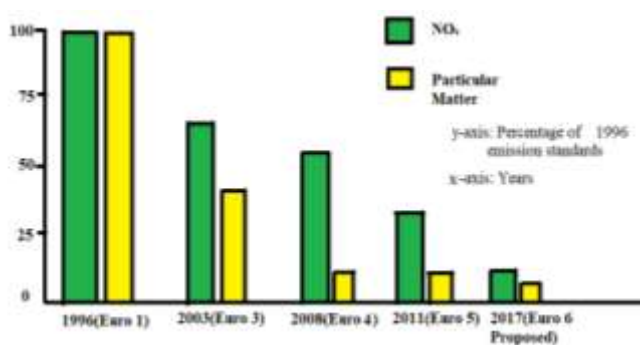

Fig-2: Emission standards for new heavy-duty engines

1.5 Smoke: The smoke generated from the industries and factories will lead to a high amount of pollutants discharged into the air which is really hazardous to living organisms. In a survey, it has been found that in developing countries, about one million people of the majority of the population used tobacco smoking [21].

According to the 2007 report, due to the usage of tobacco smoking, nearly 4.9 million people were died [22]. Therefore, smoking is the severe problem related to health in the worldwide that is about 49,000 deaths every year including of all age groups due to tobacco smoke.

1.6 LPG: It is a colorless, odorless and liquid gas. LPG is commonly known as highly flammable gases. LPG leakage can be normally identified by adding some amount of odorant into it. It can be also put under the category of mutagen and carcinogen when butadiene content is more than 0.1%. Liquefied Petroleum Gas has chances of leakage in any form that is in the form of liquid or in the form of gas which is poisonous to everyone. It causes burning with high combustion when it comes in the contact of ignition.

1.7 Humidity and Temperature: Both humidity and temperature play a vital role in our life. Humidity is responsible to prevent us from the harmful effects of the UV Rays (Ultraviolet Radiation). It is also a crucial part in maintaining the climate of the earth. Humidity plays an important role in various storage and food processing facilities. But when humidity rises, the temperature of the earth get increases which cause in higher temperature. Measurement of temperature is very important because it affects the living being and nature widely. Greenhouse effect also can be calculated with the help of temperature. We compare the temperature of the area with the past days and the present day and analyze that how much it increases or decreases in a particular area and how it affects the weather and climate of a particular area.

2. WHY THIS PROJECT

As we all know that pollution degrades the health of living being which causes a serious problem in day to day life. Due to various human activities and natural sources, there is an increase in hazardous pollutant emission. Pollution of any area can be measured by the Air Quality Index. With the increase in air quality index, there is a severe health problem in the living organism. The impact of the increase in air quality index by which living being effect can be shown in the table given below:

Table - 1: Air Quality Index in India

Air Pollution Level	Air Quality Index (AQI)	Associated Health Impacts
Good	0-50	Negligible influence or affect.
Adequate	51-100	May cause a slight breathing problem to delicate people.

Fairly polluted	101-200	May impact on people faces with lung problems such as asthma and also causes breathing problem to people with heart diseases, older people and children.
Poor	201-300	Discomfort to the people suffering from heart disease and also cause discomfort to the people on longer exposure.
Very Poor	301-400	Cause severe effect to the people who are suffering from heart and lung diseases and also cause respiratory disorder to the people on prolonged exposure.
Severe	401-500	Also affects healthy people. It may cause a respiratory-related problem and a serious problem for people suffering from heart and lung diseases. This can also impact on physical activity on healthy people.

3. BLOCK DIAGRAM

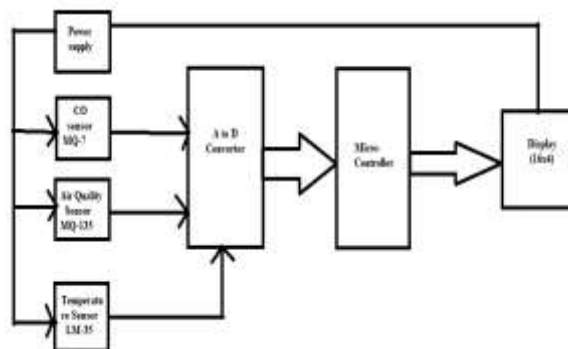

Fig-4: Block Diagram

4. AIR QUALITY MONITORING DEVICE

The different components used in the project are discussed below with their purpose:

4.1. Arduino UNO: It is a widely used hardware platform based on ATmega328P which is coded using Arduino IDE. It contains 6 analog pins and 14 digital pins. Also, it is open-source microcontroller and easily worked with different types of sensors. It can be operated by 9V DC power supply. For uploading a code we need to connect the Arduino to a system with the help of USB cable. The Arduino microcontroller has many applications. Due to its ability to achieve an intentional goal, it is not only used for a technical audience but it is also used by the artists and designers due to its focus of usability on its design [23]. It is an essential part of the framework. It can be accessible to any platform either it is software or hardware platform due to this it is also known as open-source microcontroller equipment. Arduino is compatible with many sensors available in the market. It has a board which contains everything available needed for its working. In this device, the only USB cable is required to set up connectivity with the computer or it may be using a power supply with the help of a battery source to get it started. Also, it is not costly with respect to other devices and accessed by free open-source software known as IDE (Integrated Development Software). It can be operated very easily because there is an availability of a large number of codes available on the internet. In today's scenario, there are a large number of increasing online community which are working on Arduino consist of programmer like us who share their working and becomes a reliable platform and helps the new users who start working with this microcontroller.

4.2. NodeMCU: It is an open-source IoT platform that contains firmware which works on ESP8266 Wi-Fi SoC and hardware based on the ESP-12 module. It is also known as System on Chip (SoC) Wi-Fi. It is an

In the last decades, the level of pollution due to increase in the population rising very rapidly, making it critical to have a trusted and in what way to improves the technology for controlling the air pollution and monitor the quality of the air to reduce the pollution.

We developed a device using Arduino UNO that monitors the presence of pollutants in the air. It contains various sensors for collecting different gases readings. The data collected by sensors are uploaded to the Thingspeak cloud where it is visualized, it also has an LCD module which also shows the readings. The main advantage is that it has very cost-effective than other devices that are already available in the market. The system uses very less expensive sensors to control air pollution and gives the live result of the given data. We have designed the system which is affordable to every people of the country for the purpose of reducing air pollution.

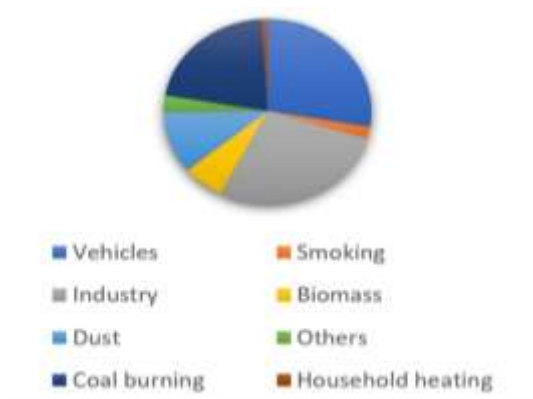

Fig-3: Sources of Pollution

integrated circuit which integrates all the basic part of the computer or other electronic devices. It connects over the internet for the application of Internet of Things and the projects related to similar technology. As compared with Arduino ATmega328P, NodeMCU is the more powerful processor which has 4MB flash memory and much more RAM. It has almost everything that Arduino does work. It has much more advantages in the field of Internet of Thing.

4.3. MQ135 Gas Sensor: It is composed of SnO₂ which is a sensitive material. The conductivity material used to manufacture MQ135 is very low in the fresh air. The value of conductivity will increase as pollutants increases in the air. It can sense gases like ammonia gas, sulphide, benzene, and carbon dioxide. The range of detection is 10-10000 ppm. It works on a voltage of 5.0±0.1 volts. In clean air, the conductivity of a material is low. The conductivity rises with the rise of the pollutants the in air. The main features of this sensor are less cost, simple circuit design, long life span, and good knowledge to hazardous and toxic gases. It has many applications in the field of industrial sites as it is largely used with commercial gas alarm, portable gas detector and also in domestic gas alarm [24]. MQ135 is used for monitoring of CO₂ present in the atmosphere. As per the examination, the value of carbon dioxide presents in the atmosphere is equal to 400 PPM [25] and on the basis of these standards, the gas sensor is calibrated.

4.4. Buzzer Module: It is an audio signaling device, which is used for the purpose of beeping. Whenever the air pollution goes above the certain threshold value or limit, the buzzer starts beeping which showing the sign of danger.

4.5. DHT11 Temperature and Humidity Sensor: Temperature and humidity are two major parameters which are important to be monitored. Everybody needs to know the temperature and humidity in the surroundings to carry on the work. DHT11 is a sensor used to measure the temperature and humidity present in the atmosphere. It generates the output in the form of a calibrated digital signal by using temperature and humidity sensing technology [29]. For the measurement of temperature, the sensor consists of a Negative Temperature Coefficient and to measure humidity, it uses resistive type components. Each and every person can view the value of temperature and humidity on the webserver or on the display unit.

5. WORKING

Firstly, all the equipment's are connected to the Arduino. For connecting the sensors to Arduino jumper wires are used. The most important step is to collect all the libraries

required for the sensors can be downloaded from the GitHub for MQ135 Gas sensor and ESP8266 Wi-Fi module. After connecting all the modules to the Arduino the code is uploaded to the Arduino by including the libraries for the sensors and the API key and Wi-Fi Credentials are also included in the code. As the code is uploaded the readings are starting to appear on the LCD display and Thinkspeak cloud. When there is an increase in the harmful gas the buzzer starts ringing.

MQ135 gas sensor is used to detect NH₃, Nitrogen Oxide Benzene, Alcohol, Smog, Carbon dioxide, and various other gases, that's why this is the best gas sensor for using in this project. When the sensor is connected to the Arduino then it will start detecting the gases present in the air and reading will start to appear on the LCD and Web Server. MQ135 generates the output in the form of voltage levels which is changed to the PPM. For that a library is used for MQ135 is used in the code. The operating range of MQ135 sensor is 0 to 10000 PPM. The value of good air is set to be 350 PPM. If the value exceeded over 1000 PPM it will alarm by beeping the buzzer and LCD show "Unhealthy Air". If reaches above 2000 then the buzzer will start beeping and LCD will show "Highly Polluted Air! Go to clean Air" and if the value is below 1000 it will show "Fresh Air".

V. CONCLUSION

With the use of the Internet of Things, there is an improvement in the process of monitoring of various pollutants present in the air. By the use of MQ135 gas sensor, it can sense various types of hazardous gases and Arduino in which controls the entire process. Node MCU provides connectivity to the internet and for displaying the output LCD module is used. The buzzer starts beeping when the quality of air degraded in a very severe manner and monitor it by sending an alert message to the user and related precaution have been taken. The air quality monitoring system conquers the problem with high-polluted places. It provides support to the latest technologies, also it is very cheaper than other devices available in the market. There is also a feature of showing the data on the smartphone by installing the application from the internet. It is proposed that this project get good market support because this system helps in reducing the air pollution by using the IoT technology and furthermore, it will also acceptable at a global level using their complete monitoring system.

REFERENCES

[1] Tudose, D. Ş., Pătraşcu, N., Voinescu, A., Tataroiu, R., and Țăpuş N., "Mobile Sensors in Air Pollution Measurement.", in Positioning Navigation and Communication (WPNC), IEEE, pp. 166-170, 7 Apr 2011.

- [2] TERI. 2015. Air Pollution and Health. Discussion Paper by The Energy and Resources Institute: New Delhi by Rinki Jain (Associate Fellow, TERI), Karnika Palwa (Research Associate, TERI)
- [3] João Ramos Maria, João Dias, "Analyses of Indoor Environmental Quality and Ventilation in a Building of a School of Higher Education in Portugal", in the 4th Advanced Research in Scientific Areas conference, pp. 273-278, 1 Nov 2015.
- [4] Dias, M. J. et al., (2010). "Indoor Air Quality Evaluation in School Buildings Ventilated by Natural and Mechanical Systems". Clima pp. R6TS62-0P02, Turkey: REHVA. ISBN Code of the CD 978-975-6907-14-6, 2010.
- [5] Olesen, B. W., & Brager, G. S., "A Better Way to Predict Comfort: The New ASHRAE Standard 55-2004", ASHRAE Journal, pp.20-26, 8 Aug 2007.
- [6] Al-Haija, Q. A., Al-Qadeeb, H., & Al-Lwaimi, A., "Case study: Monitoring of air quality in king Faisal University using a microcontroller and WSN", Procedia Computer Science, volume 21, pp. 517-521, 31 Dec 2013.
- [7] Sricharan, K. S., Shrivasan, M. A., & Kumar, S. S., "An Intelligent Automated Emission Quality Monitoring System Designed to Test the Vehicles in the Signal", in Green Computing, Communication and Conservation of Energy (ICGCE), International Conference on IEEE, pp. 590-593, 12 Dec 2013.
- [8] Zhang, S., & Zhang, H., "A Review of Wireless Sensor Networks and its Applications", in Automation and Logistics (ICAL), IEEE International Conference on pp. 386-389, 15 Aug 2012.
- [9] Mahmoudzadeh, B., & Faez, K., "HCTT&R: A Complete Scheme for Object Tracking and Recovery of Lost Objects in Cluster-Based Wireless Sensor Networks", in Telecommunications (IST), Sixth International Symposium IEEE conference, pp. 691-696, 6 Nov 2012.
- [10] Qasem Abu Al-Haija, "Toward Secure Non-Deterministic Distributed Wireless Sensor Network Using Probabilistic Key Management Approaches", Journal of Information Assurance and Security, Vol-6, issue-1, pp. 10-18, 2010.
- [11] Polastre, J., Szewczyk, R., Sharp, C., & Culler, D., "The Mote Revolution: Low Power Wireless Sensor Network Devices", in Hot Chips, Vol. 16, pp. 22-24, 22 Aug 2004.
- [12] Jeffrey M. Sadler, Daniel P. Ames, Rohit Khattar, "Open-Hardware Meets Open Software for Environmental Monitoring", in International Environmental Modelling and Software Society (iEMSs), San Diego, CA, USA, 2014
- [13] Wang, H., Wu, T., & Wu, G., "Air Quality Monitoring System Based on Frequency Hopping System", in Intelligent Control and Information Processing (ICICIP), IEEE Conference, pp. 641-64, Aug 2010.
- [14] Raja Vara Prasad Y, Mirza Sami Baig, Rahul K. Mishra, P. Rajalakshmi, U. B. Desai⁵ And S.N. Merchant,, "Real-Time Wireless Air Pollution Monitoring System" Ictact Journal On Communication Technology: On Next Generation Wireless Networks And Applications, Vol. 2, Issue 2, June 2011.
- [15] Devarakonda, S., Sevusu, P., Liu, H., Liu, R., Iftode, L., & Nath, B., "Real-time Air Quality Monitoring Through Mobile Sensing in Metropolitan Areas", in Proceedings of the 2nd ACM SIGKDD International Workshop on Urban Computing, pp. 15, Aug 2013.
- [16] Prockop, L. D., & Chichkova, R. I., "Carbon Monoxide Intoxication: An Updated Review", Journal of the neurological sciences, Vol. 262, Issue 1, pp.122-130, 15 Nov 2007.
- [17] Buckley, N. A., Isbister, G. K., Stokes, B., & Juurlink, D. N, "Hyperbaric Oxygen for Carbon Monoxide Poisoning: a Systematic Review and Critical Analysis of the Evidence", Toxicological Reviews, Vol. 24, Issue 2, pp. 75-92, 1 Jun 2005.
- [18] Weaver LK, "Clinical practice. Carbon Monoxide Poisoning". The New England Journal of Medicine, Vol. 3601, Issue 12, pp. 1217-1225, Mar 2009.
- [19] Asmi, A., Putra, J. C. P., & Rahman, I. B. A., "A Study of Indoor Air Quality of Public Toilet in University's Building", in Humanities, Science and Engineering (CHUSER), IEEE Colloquium ,pp. 403-408, 3 Dec 2012.
- [20] Raza A. Khan¹ et al, "Impact of HVAC Systems on IAQ in Building Environment" International Journal of Advance Research, in Science And Engineering, IJARSE, Vol. 3, Special Issue1, Sep 2014.
- [21] "Tobacco Fact Sheet N°339". May 2014. Retrieved on 13 Mar 2016.
- [22] West, Robert and Shiffman, Saul, "Fast Facts: Smoking Cessation. Health Press Ltd." pp. 28. ISBN 978-1-903734-98-8, 2007.
- [23] Diakopoulos, D., & Kapur, A., "HIDUINO: A Firmware for Building Driverless USB-MIDI Devices Using the Arduino Microcontroller", in NIME, pp. 405-408, May 2011.
- [24] Ali Al-Dahoud et al., "Monitoring Metropolitan City Air-quality Using Wireless Sensor Nodes based on ARDUINO and XBEE", International Conference on Circuits, Systems, and Signal Processing, communication and computers, pp. 121-125, Mar 2015.