

Car Accident Detection and Notification: An Analytical Survey

Mantra Sanathra¹, Angel Parmar², Kelvin Parmar³, Dhruvil Patel⁴, Mittal Darji⁵

^{1,2,3,4}Research Scholar, G.H. Patel College of Engineering and Technology, V.V. Nagar, Gujarat, India

⁵Assistant Professor, G.H. Patel College of Engineering and Technology, V.V. Nagar, Gujarat, India

Abstract — We lose a considerable amount of people due to road accidents around the globe. To reduce this, an automated system can be helpful which can improve the chances of immediate treatment to save the injured. Some work in this direction is already achieved by researchers and in this paper, such work was studied. Also, a system is proposed from the review which can detect the incident of accident using sensors and notify the nearby ambulance to seek immediate help. Victim's relatives can also be notified using this system. This kind of a system can be of prime use when the accidents occur at a remote place. As many references assure that 90% of road-traffic accidents occur at low speed of the vehicle [1]. Proposed system work in two phases: detection is the first where sensors like speed, vibration and collision are used identify the accident. Second phase is of notification where the system uses GSM and GPRS to send the message asking for a help with the location of the victim.

Keywords- Automated accident detection, Sending notification, Sensing mechanism, Location detection, Smart phones

1. INTRODUCTION

A Road accident due to traffic control issues is a problem worldwide. The number of people caused injuries or death due to road accidents are large in number. According to statistical projection of traffic fatalities, the two-year comparison of total driver participation in mortal crashes presented a three percent increase from 43,840 in 2011 to 45,337 in 2012. Additionally 184,000 young drivers (15 to 20 years old) were injured in vehicle crashes, in 2012, an increase of two percent from 180,000 in 2011.[2]

In majority of the cases, the injured person cannot receive the immediate treatment due to some reasons. The accident might have happened at some remote or lonely place or the person is too injured and unable to call a help himself immediately. If in this kind of cases, we can build a system which can do this task of asking immediate help, we can save many lives. Accident detection sensors can be installed on the roads but this solution seems very time taking and costly. Instead of this, if we develop detection mechanism in the vehicle itself, it would become cheaper and feasible too.

These days' smart phones are easily available with everyone and users carry their phones all the time. We can take the help of smart phones for sending notifications to ambulance and relatives of the victim.

In this paper further reviews are provided of the existing work proposed or implemented by researchers. From these, a similar system is proposed using sensor technology, GSM and GPRS which can perform the task of accident detection and notification.

II. RELATED WORK

According to a journal published in International Journal of Advanced Research in Electrical, Electronics and Instrumentation Engineering developed by C.Prabha, R.Sunitha and R.Anitha; at present criteria, we cannot detect where the accident has occurred and hence no information related to it, leading to the death of an individual. The research work is going on for tracking the position of the vehicle even in dark clumsy areas where there is no network for receiving the signals. In this project GPS is used for tracking the position of the vehicle, GSM is used for sending the message and the ARM controller is used for saving the mobile number in the EEPROM and sends the message to it when an accident has been detected. Hence with this project implementation we can detect the position of the vehicle where the accident has occurred so that we can provide the first aid as early as possible. [3]

Abha Damani, Hardik Shah, Krishna Shah published a journal in International Journal of Computer Applications which is concentrated on determining location using GPS module. Global Positioning System is globally used for the tracking and navigation purpose. GPS is mainly used in the military, farming, civil, transportation and commercial users around the world. In their review paper, they have described how GPS Tracking System works and where it is useful in real world environment. They have compared different algorithms like Localization algorithm, kalman filter algorithm and methodologies like GPS, GPRS, GSM, GIS, GSM and RFID and have identified some problems of GPS. [4]

Wattanawisuth published a conference paper in IEEE conference in January 2012, which presents an overview of wireless black box using MEMS accelerometer and GPS tracking system which is developed for accidental monitoring. The system consists of cooperative components of an accelerometer, microcontroller unit, GPS device and GSM module. In the event of accident, this wireless device will send mobile phone short message indicating the position of vehicle by GPS system to family member, emergency medical service (EMS) and nearest hospital. The threshold algorithm and speed of motorcycle are used to determine fall or accident in real-time. The system is compact and easy to install under rider seat. The system has been tested in real world applications using bicycles. The test results show that it can detect linear fall, non-linear fall and normal ride with high accuracy. [5]

A conference paper published by Hoang Dat Pham in IEEE conference in December 2013; represented the ability to track vehicles which is useful in many applications including security of personal vehicles, public transportation systems, fleet management and others. Furthermore, the number of vehicles on the road globally is also expected to increase rapidly. Therefore, the development of vehicle tracking system using the Global Positioning System (GPS) and Global System for Mobile Communications (GSM) modem is undertaken with the aim of enabling users to locate their vehicles with ease and in a convenient manner. The system will provide users with the capability to track vehicle remotely through the mobile network. This paper presents the development of the vehicle tracking system's hardware prototype. Specifically, the system will utilize GPS to obtain a vehicle's coordinate and transmit it using GSM modem to the user's phone through the mobile network. The main hardware components of the system are u-blox NEO-6Q GPS receiver module, u-blox LEON-G100 GSM module and Arduino Uno microcontroller. The developed vehicle tracking system demonstrates the feasibility of near real-time tracking of vehicles and improved customizability, global operability and cost when compared to existing solutions. [6]

A conference paper published in IEEE conference in August 2012, by Fogue, focused on the detection of an accident and providing faster assistance. In this paper, e-NOTIFY system is presented, which allows fast detection of traffic accidents, improving the assistance to injured passengers by reducing the response time of emergency services through the efficient communication of relevant information about the accident using a combination of V2V and V2I communications. The proposed system requires installing OBUs in the vehicles, in charge of detecting accidents and notifying them to an external CU, which will estimate the severity of the accident and inform the appropriate emergency services about the incident. This architecture replaces the current mechanisms for notification of accidents based on witnesses, who may provide incomplete or incorrect information after a long time. The development of a low-cost prototype shows that it is feasible to massively incorporate this system in existing vehicles. [7]

III. PROPOSED SOLUTION

Based on the review, in this section, a system is proposed in order to provide fast and accurate rescue services for the injured people in accidents. The developed system, called Car Accident Detection and Notification, consists of two phases; the detection phase, explained in the next section 3.1., which is used to identify the occurrence of accident and notification phase, explained later in the section 3.2., which is used to inform nearest emergency center or ambulance for a fast response and recovery.

3.1. Automated Detection



Figure 1. Accident detection

In the first part of the system, detecting the accident is based on the hardware parts. It contains three different sensors to detect the accident. The sensors used for the sensing mechanism are vibration sensor, speed sensor and collision detection sensor. The vibration sensor is set default with a valid amount of vibration that can occur while car is being driven. Whenever the accident occurs, the vibration level of the car gets drastically changed. This change in vibration is sensed by

the vibration sensor which helps to detect the accident accurately. The second sensor used is the speed sensor, which basically works on the major amount of change in the speed of car. The collision detection sensor is a dedicated sensor developed to identify collisions between two solid bodies. Whenever a vehicle collides with something, a built-in pin in this sensor gets pressed and occurs a rapid change in the voltage which helps detecting the collision. These sensors detect changes and notify the smart phone application about the accident.

3.2. Sending Notification

The second part of our system is 'Sending Notification' which relies on the android application developed. Just after the accident being detected by the hardware part of the system, it is necessary to forward this message to the nearest hospital and to the relatives of the victims according to our aim. This task is performed by the application, which is connected with two modules: GPS and GSM attached to the hardware part. The exact location of the car accident has to be identified in order to get the help or to call the ambulance. This task is done using GPRS module, which helps determining the location of the car by sensing the latitude and longitude values of the car accurately. Once the location of the car is derived, the application searches for the nearest hospital to obtain ambulance service and sends the message notification to them using GSM module. The ESP32 microcontroller chip can be used to connect the GPRS and GSM modules with sensors and to provide an interface between hardware components and software application. The application also sends a notification to the victim's close relatives using GSM module. This way, we can develop our application for sending the message notification. From some experts' advice and experimental work, we were introduced to an issue of the developed device considering a very normal or little change in the default levels of speed and vibration as an accident and sending notification for rescue. This situation was really unwanted and serious which needed to be fixed. To provide a solution to this problem, we updated our application that now asks the user or the accident victim if they really need the help of an ambulance or first aid. This message gets displayed on the screen of user's mobile phone for 10 seconds. If the user doesn't want any help, he can simply click on the 'No' button and no notifications will be sent. In the case of user being heavily injured, or phone being damaged, immediately after 10 seconds of no response from the user, the application considers it as an accident and sends a message notification in order to get help.

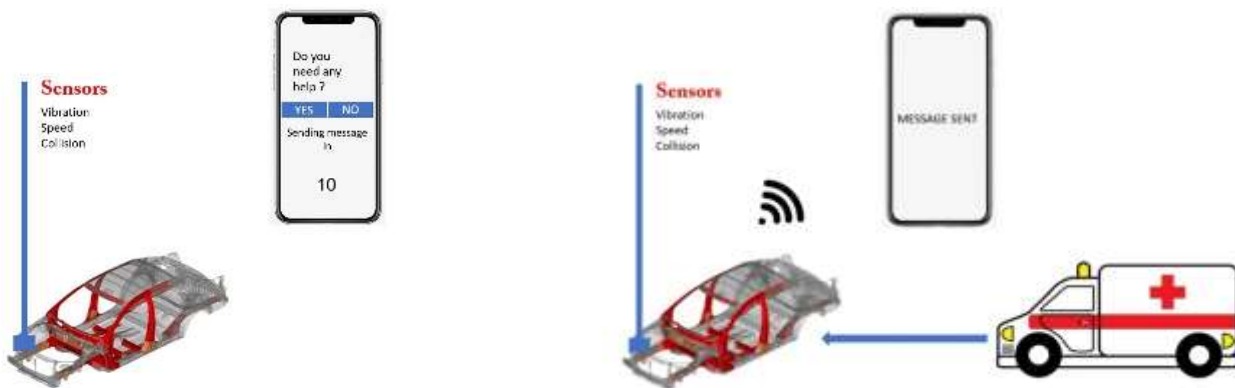

Figure 2. Sending notification

3.3 System block diagram

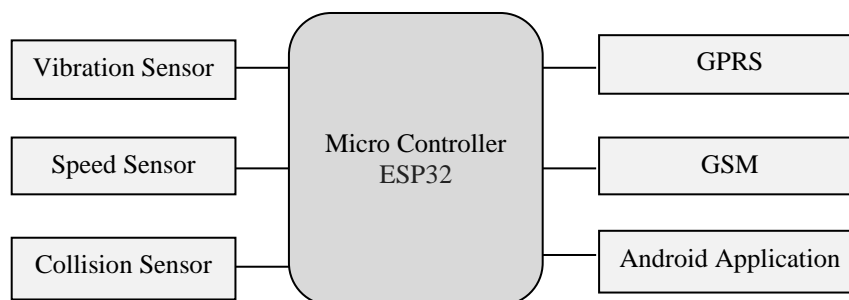

Figure 3. Proposed system

IV. CONCLUSION

Related experimental work and experts' suggestions have been considered in the troubleshooting part and we can say that the proposed system would work well in various situations. The detection part can detect the accident and collisions accurately with the help of three sensors used and the software application can send the notification to rescue service rapidly using GSM and GPS modules. Thus, the developed system can be of tremendous help in critical situations of accidents. Using this kind of systems in vehicles, we can reduce the death rate due to road accidents.

V. REFERENCES

- [1] Evanco and William M., "The Impact of Rapid Incident Detection on Freeway Accident Fatalities", technical report available from Mitretek (centre for information system), McLean, Virginia, USA, report No .WN 96W0000071, June 1996.
- [2] National Highway Traffic Safety Administration (NHTSA), Dept. of Transportation (U.S),"Traffic safety facts 2012: Young Drivers", Washington (DC), April 2014.
- [3] C.Prabha, R.Sunitha and R.Anitha, "Automatic Vehicle Accident Detection and Messaging Using GSM ans GPS Module" International Journal of Advanced Research in Electrical, Electronics and Instrumentation Engineering (An ISO 3297: 2007 Certified Organization) Vol. 3, Issue 7, July 2014.
- [4] Abha D., Hardik S., Krishna S., "Global Positioning System for Object Tracking" International Journal of Computer Applications (0975 – 8887) Volume 109 – No. 8, January 2015.
- [5] Watthanawisuth N., "Wireless black box using MEMS accelerometer and GPS tracking for accidental monitoring of vehicles", IEEE conference in Jan, 2012.
- [6] Hoang Dat Pham, "Development of vehicle tracking system using GPS and GSM modem" IEEE conference in Dec, 2013.
- [7] Fogue, M. "Automatic Accident Detection: Assistance Through Communication Technologies and Vehicles", IEEE conference in August, 2012.
- [8] T Kalyani, S Monika, B Naresh, Mahendra Vucha "Accident Detection and Alert System", IJITEE, ISSN: 2278-3075, Volume-8 Issue-4S2 March, 2019.
- [9] Tanushree Dalai, "Emergency Alert and Service for Automotives for India", International Journal of Advanced Trends in Computer Science and Engineering (IJATCSE) Mysore India, vol. 2, no. 5, pp. 08-12, 2013.
- [10] Nimisha Chaturvedi, Pallika Srivastava . "Automatic Vehicle Accident Detection and Messaging System Using GSM and GPS Modem ",Volume: 05 Issue: 03 | Mar-2018.