

INVESTIGATION OF DESIGN PARAMETERS THAT AFFECT THE PERFORMANCE OF ANGULAR CONTACT BALL BEARING: A REVIEW

Priya Tiwari¹, Samant Raghuwanshi²

¹M.E. Scholar, Department of Mechanical Engineering, Jabalpur Engineering College, Jabalpur, India

²Assistant Professor, Department of Mechanical Engineering, Jabalpur Engineering College, Jabalpur, India

Abstract - Angular contact ball bearing can take both radial and axial loads and thus are widely used in high speed applications. Therefore, it is important to analyse the various factors that affect the bearing life and its performance. This research mainly focuses on the design and analysis of angular contact ball bearing and aims for determining the parameters affecting the performance of the angular contact ball bearing. This paper represents the literature review of the ball bearing. The bearings subjected to various working conditions are analysed using analytical and FEA stimulation method. The different parameters that affect the bearing performance and its fatigue life are investigated and discussed in this paper. This will help in optimizing the bearing performance which will give high load carrying capacity, reduce weight, improves wear resistance as well as fatigue life of the bearing.

Keywords: angular contact ball bearing, bearing life, FEA stimulation, bearing performance, load carrying capacity.

1. INTRODUCTION

The rolling bearing consists of four main parts namely inner race, outer race, ball or roller and retainer. The inner race is carried by the rotating shaft and the outer race mounted on the bearing housing is mostly stationary. The balls or roller are held in angularly spaced relationship by retainer. The rolling elements provide relative motion between surfaces by action of rolling with small amount of slip. Therefore, frictional force acting between the surfaces is due to rolling resistances. Angular contact ball bearing are the rolling bearing elements that can be subjected to both radial and axial loads or only axial load depending on the magnitude of the contact angle. The inner and the outer race are so designed that the line of action makes an angle with the axis of the bearing. The load carrying capacity of single row angular contact ball bearing is higher than that of deep groove ball bearing.

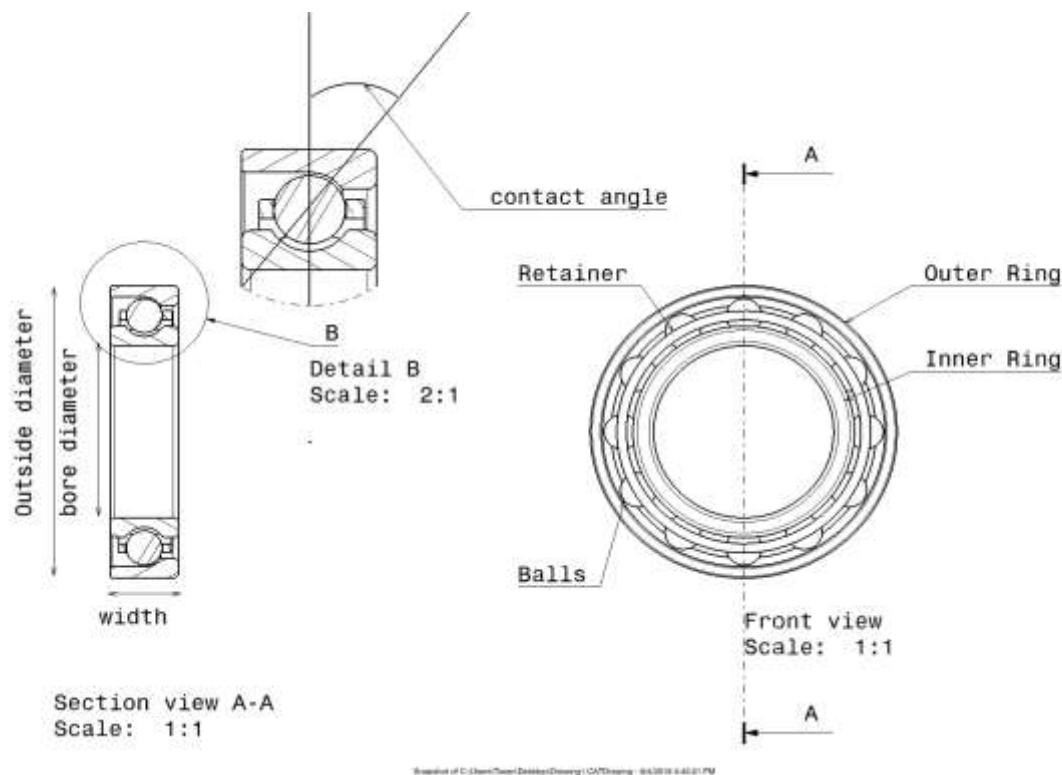

Figure no.1-Schematic arrangement of angular contact ball bearing

1.1 Objective

1. To investigate the parameters which affect the performance of the ball bearing
2. To optimize these parameters of the bearing for improving the performance giving low weight, high load carrying capacity and wear resistance, and provides maximum fatigue life and minimum deformation.

2. LITERATURE REVIEW

Fengtao Wang et al[1]

In this paper, the investigation is carried out to study the effect of the structural parameters and working conditions on the judgemental factors such as contact angle, contact stiffness, contact angle and edge distance of the ball bearing. For this, a six degree dynamic model with time varying contact stiffness was developed and a comparison validation is carried out. The results have shown that initial contact angle, number of balls, inner raceway curvature factor, axial load and shaft speed have great influence on the judgemental factors of the ball bearing. Also, inner raceway misalignment gives more harmonics frequency and influence the stable motion of the ball bearing.

Anoopnath P.V. et al[2]

This paper considers deep groove ball bearing for the analysis of ball raceway contact mechanism based on hertz contact theory and MESYS tool analysis. The calculation of maximum contact pressure is done at different loads to perform the analysis for contact pressure between inner raceway and the ball of single row deep groove ball bearing. The analytical and MESYS results are compared and are found to be in good agreement.

Wei Guo et al[3]

This paper investigates the fatigue life of 7311B angular contact ball bearing by considering a quasi-static model. The bearing is subjected to various working conditions such as radial load, axial load and rotational velocity. The coupling model of life and damage which considers the mechanical property of bearing is established to predict the fatigue initiation life of bearing parts and quantitatively verified through accelerated life test. The results have shown that as rotational velocity increases, the fatigue life of inner race and the roller increases while that of outer race decreases. It is also observed that the fatigue life of three parts decreases with increase in axial load. Also, the fatigue life of outer race and the roller decreases while that of inner race increases a little bit as the radial load increases.

Shubham B. Kadam[4]

The investigation is carried out to analyse the effect of different material and its selection for the reliable performance of the ball bearing. This is done using FEA stimulation and experimentation for optimizing the ball bearing material. For this, comparative analysis of different materials such as stainless steel, aluminium oxide, zirconium oxide and silicon nitride, is performed under different loads. The results have shown that zirconium oxide that is having less density, high wear resistance and lower coefficient of thermal expansion, is better than other materials for the ball bearing.

Darshan Adeshara et al[5]

This paper considers development of the integrated clutch lifter angular contact bearing in place of deep groove ball bearing. A review is done to replace the deep groove ball bearing by angular contact ball bearing in two and three wheeler clutch. It concluded that the angular contact ball bearing when used in two wheeler clutch increases the bearing fatigue life, minimizes the assembly time, reduced the cost as well as weight when compared to deep groove ball bearing arrangements in two wheeler clutch.

Baomin Wang et al[6]

This paper investigates the effect of different materials fatigue life of inner race, ball and outer race of angular contact ball bearing. The bearings which are selected for the investigation are full steel bearing, hybrid ceramic bearing and full ceramic bearing. The results have shown that bearing fatigue life is mainly determined by the fatigue life of outer ring. The contact load is mainly affected by change of contact angle and centrifugal force of ball. Bearing fatigue life is maximum for full steel angular contact ball bearing and for moderate and high speed, bearing fatigue life is maximum for hybrid ceramic ball bearing.

Putti Srinivas Rao et al[7]

The static structural and transient dynamic analysis is carried out for 6200 deep groove ball bearing using ANSYS software. The bearing is subject to different radial loads and materials (for simple ball bearing-steel and aluminium oxide, and for hybrid ball bearing-zirconium oxide and aluminium oxide) for determining total deformation, Von-Mises stress, equivalent strain, deformation and contact pressure. The results have shown that the ceramic ball bearing shows better results than steel and the impact load bearing capacity of ceramic bearing is higher than that of hybrid and steel bearings. Also, theoretical and ANSYS results when compared are found to be in good agreement. And results obtained from transient dynamic analysis and static structural analysis are approximately the same.

3. CONCLUSION

In this paper the emphasis is laid to review and summarize different parameters that affect the bearing performance and its fatigue life. From the above literature survey, we can conclude that the factors that affect the bearing performance are material, raceway groove curvature factor, number of balls, preloads, loading conditions such as radial load and axial load, shaft speed, contact angle, friction coefficient, contact stiffness, ball sizes and raceway misalignment. An effort should be made to design the bearing that optimizes these parameters and results in minimum deformation, increases the bearing performance which will give high load carrying capacity, low weight, and high wear resistance, and at the same time maximizes the fatigue life of the bearing.

4. REFERENCES

- [1]Fengtao Wang, Minquig Jing, Hongwei Fan, Yaobing Wei, Yang Zhao and Heng Liu, "Investigation on contact angle of ball bearings", Institution of mechanical engineers, Vol. 231(1) 230-251,2016.
- [2]Anoopnath P.R., V. Suresh Babu, Vishwanath A.K., "Hertz contact stress of deep groove ball bearing", ELSEVIER, Proceedings 5 3283-3288, 2016.
- [3]Wei Guo, Hongrui Cao, Zhengjia He and Laihao Yang, "Fatigue life analysis of rolling bearings based on quasistatic modeling", Hindawi Publishing Corporation, Article ID 982350, Volume 2015.
- [4]Shubham B. Kadam, Prof. P.G. Patil, Prof. R.Y. Patil, "Contact stress analysis & material optimization of ball bearing using Hertz contact theory", Volume 5, Issue 1, International Research Journal of Engineering and Technology, IISN: 2395-0072, 2018.
- [5]Darshan Adeshara, Dr. Pranav Darji, "A review of design and analysis of angular contact ball bearing for two wheeler clutch", International Journal of Advanced Engineering and Research Development", Volume 2, Issue 5, 2015.
- [6]Baomin Wang, Chao Gao, Bing Du, Wu Zaixin, " The effect of materials on fatigue life of angular contact ball bearing", International Journal of Stimulation Systems, Science & Technology, Volume 2017.
- [7] Putti Srinivasa Rao, Narise Saralika, "Static structural and transient dynamic analysis of 6200 deep groove ball bearing", SSRG International Journal of Mechanical Engineering, IISN: 2348-8360, 2017.
- [8] Bharat Bhushan, "Introduction to Tribology", second edition, Wiley Publication.