

# Design and Analysis of Progressive Die for Industrial Component Tail Gate Stricker

Jayshree M. Gadhe<sup>1</sup>, A. Yadao<sup>2</sup>

<sup>1,2</sup>Department of Mechanical Engineering, G. H. Raisoni College of Engineering & Management, Pune, India.

\*\*\*

*Abstract: In sheet metal manufacturing, Design and development of different components is one of the important phase. This is a highly complex process and leads to various uncertainties. These uncertainties can induce heavy manufacturing losses through premature die failure, final part geometric distortion and production risk. Progressive die is a press tool of collective operations performed on the sheet metal. The various operations are carried out in a single stroke. The design of progressive die is largely depends on material of sheet metal, thickness of sheet metal and complexity of design and operations. This press tool has significance like high rate of production and minimum per unit cost of product. In progressive die the variety of operations are performed at common work station. In present project the intensions is given on quality improvement along with production rate and cost minimization. Progressive die components are modeled in CATIA with selected dimensions for sheet metal plate. Finite element analysis is conducted for Progressive die obtaining deformation and stresses on sheet metal component by using ANSYS software.*

*Keywords- Sheet metal, Die, Catia, Ansys*

## I. INTRODUCTION

The design and manufacture of press tools, or punches and dies, is a branch of production technology that has extended into many lines of engineering manufacture over the past seventy years. There is no doubt that the accuracy achieved by new ideas in design and construction applied by the press tool designer, coupled with increased speed and rigidity of the presses etc. used have all contributed toward maintaining this form of metal tooling well to the force as a means of obtaining pleasing, yet strong, durable articles that can withstand severe day-today usage. Design of sheet metal dies is a large division of tool engineering, used in varying degree in manufacturing industries like automobile, electronic, house hold wares and in furniture. There is no doubt that accuracy achieved by the new ideas in design and construction applied by the press tool designer, coupled latest development made in related fields made more productive, durable and economical. Hardened and toughened new martial & heat treatment process made the design easy.

Progressive die can perform many operation compared to other dies and also it can able to eliminate the loading & unloading time which results in faster production rate.

It has become the practice more and more to produce from sheet metal by some form of pressing process, work pieces that would have been made from bar, forging or casting two or three decades ago. Also, the handling of both strip material and semi-finished components has assumed an importance simply because fast and efficient movement means cheap products from operators who do not suffer fatigue from the handling of awkward or heavy components. However, it should not be forgotten that press design has made many advances in recent years in common with, for example, the machine tool industry, and machines are now available that are capable of withstanding the heavy stresses set up in many modern production process. So development of a computer-aided progressive die design and machining is become beneficial because of the ability to build precision tooling in less time and at a lower cost. The component to be formed in this project is known as tailgate striker of an automobile vehicle head/backlight assembly. It is assembled with nut bolt to fit with other parts in assembly. This project is divided into following parts:

- 1) Design of a progressive die according to the dimensions of the component.
- 2) 2D & 3D modelling of a progressive die.
- 3) Static structural and modal analysis of a progressive die for evaluation of frequencies and stresses.
- 4) Manufacturing of progressive die and result interpretation.
  - i) Design of a progressive die according to the dimensions of the component. Various design steps are followed for design of progressive die by using standard references. From the dimensions of given component the die is designed.
  - ii) 2D & 3D modelling of progressive die- By using the design data, we develop a 2D & 3D models of progressive die. For 2D model we used AutoCad and for 3D Unigraphics NX is used.
  - iii) Static structural and modal analysis of a progressive die for evaluation of

frequencies and stresses. After developing the 2D & 3D models finite element analysis is done on the 3D model. Static structural and modal

AutoCad and for 3D Unigraphics NX is used.

iii) Static structural and modal analysis of a progressive die for evaluation of frequencies and stresses. After developing the 2D & 3D models finite element analysis is done on the 3D model. Static structural and modal analysis are carried out and frequencies and stresses are evaluated for further analysis of results.

iv) Manufacturing of progressive die and result interpretation. After analysis is done the die is manufactured and experiments are carried out for result interpretation. Sufficient area to prevent undue wear. It has even expansion under thermal load should be free as possible from discontinuities

## II. METHODOLOGY

Project started with collecting necessary information. Literature related to progressive die and also various research papers are gathered and studied. For execution of project which methods to be implemented are studied and discussed.

The dimension of the product is given by the enterprisers. By calculating the dimensions required for required progressive die we will go for the 3D model of. By using 3D software we will develop a 3D model. We used AutoCad for 2D model and Uni-graphics NX for 3D model.

After development of 3D model finite element analysis is done. In that we have performed static structural and nodal analysis for evaluation of various stresses and frequencies respectively.

Later on the basis of results of FE analysis we manufactured a required progressive die. Then experiments are performed on it.

After that we prepared the results.

## III. DESIGN AND CALCULATION

Design Considerations of a component

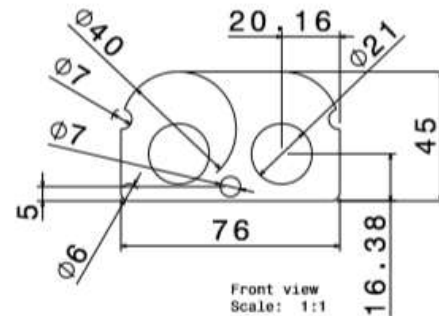

Material	MS
Thickness of Material	= 1mm
Shear Strength	= 400 N/mm <sup>2</sup>
Length	= 76mm
Width	= 45mm
Pierce diameter d <sub>1</sub>	= 21mm
Pierce diameter d <sub>2</sub>	= 7mm
Fillet radius R <sub>1</sub>	= 20mm
Fillet radius R <sub>2</sub>	= 3mm

We will perform piercing and blanking operations for development of a component. Material HCHCr is selected for die as it is hardened material.

### Punch and Die Size for Piercing Holes:

In piercing punch is made equal to component while die is made larger (component size+2C) Where, C is cutting clearance,  

$$C = 0.01 \times t \times 3\sqrt{\tau_{max}/10}$$
 = 0.06mm per side  
 Thus, die size, Ø7.12mm and Ø21.12mm

### Punch and Die Size for Complete Blanking:

Length = 76mm,  
 Width = 45mm,

R1 = 20mm,  
R2 = 3mm

Here, size of die would be same as size of the original blank.

**Cutting Force Calculations:**

Cutting force,  $F_{sh} = L \times t \times \tau_{max}$  Where,  
 $L =$  blanking periphery + piercing periphery Also  
 $= 376.665m$  Thickness of  
 area of cutting=  $2000mm^2$  Thus, cutting  
 material = 1mm  $F_{sh} = 376.665 \times 1 \times 400$   
 force, =  
 $150666 N$   
 $15.06Ton$

**Actual Press Tonnage,** Press  
 tonnage =  $1.3 \times F_{sh}$  = 1.3  
 $\times 15.06$   
 $19.578 \approx 20 ton$  = **Die**

**Plate Thickness** Here,  $T_d =$   
 $\sqrt{(3F_{sh}/\tau) \times [(B/A)^2/1 + (B/A)^2]}$  Where,  $B =$   
 width of blank  
 $A =$  length of blank =  
 $\sqrt{(3 \times 1500666/400) \times [(45/76)^2/(1 + (45/76)^2)]}$   
 $= 17.12$   
 $17.12 + 3mm$  ...(for standard size 3mm is added to  $T_d$ )  
 $= 20.12mm$   
 $= 22mm \approx 25mm$  ...(25mm  $D_2$  material block standard  
 size Considered

for deflection,  $\delta = FL^3/192EI$   
 where,  $I = bh^3/12$   
 $150666 \times 330^3/192 \times 2.1 \times 10^5 \times 221833.34$   
 $0.6053 mm$  = **Top**

**Plate** Top plate=  
 $2 \times$  die thickness =  $2 \times 22$   
 $= 44mm \approx 45mm$  For  
 deflection,  $\delta =$   
 $FL^3/48EI$   
 $150666 \times 330^3/354 \times 2.1 \times 10^5 \times 1898437.5$   
 $= 0.2829mm$  =

**Bottom Plate** Bottom plate =  $2 \times$  die plate thickness =  
 $2 \times$  die plate thickness =  
 $2 \times 22$   
 $44mm \approx 45mm$  For  
 deflection,  $\delta =$   
 $FL^3/354EI$   
 $150666 \times 330^3/354 \times 2.1 \times 10^5 \times 1898437.5$   
 $0.03836mm$  =

**Guide Pillar Calculations**

Shut  
 Height=160mm  
 Press tonnage= 20 tons  
 So we will use 4 pillars here  
 For single pillar force tonnage=  $20/4$   
 $= 5 ton/per pillar$   
 Here the load that will act on pillar is the crippling load  
 For crippling load,  
 $P = \pi^2 EI/L_e^2$   
 $5000 \times 9.81 = \pi^2 \times 2.1 \times 10^5 \times I/320$   
 $I = 2423.37mm^4$   
 Crippling Stress for M.S.  
 $\sigma_{cr} = 250 MPa$   
 $\pi^2 E/\lambda^2$  thus,  $\lambda =$   
 $91.05$   $\lambda =$   
 $L_e/K$   $91.05$   
 $= 320/K$   $K =$   
 $3.514mm$  Now,  $I =$   
 $AK^2$   $2423.37 = A \times (3.514)^2$   
 $A = 196.25mm^2$   
 Where,  $A = (\pi/4) \times d^2$   $D =$   
 $15.08mm$  For  
 safety it is taken as twice of calculated Thus,  
 $D = 30mm$   $A =$   
 $706.85mm^2$  Now again,  
 $I = AK^2$   $2423.37 = 706.85 \times K^2$   
 $K = 1.851mm$   $\lambda =$   
 $L_e/K$  =  
 $320/1.851$  =  
 $172.82$   $\sigma_{cr} =$   
 $\pi^2 E/\lambda^2$  =  
 $69.39N/mm^2$  which is safe for M.S.

**Strip Layout**

Here, Area  
 Area of Product=  $3000mm^2$  Area  
 of Sheet=  $102.5 \times 10^3 mm^2$  Total  
 number of blank per sheet Total  
 length of sheet= 1250mm Total  
 length of single product=51mm Number of  
 blank=  $1250/5$  = 24.5  
 Thus number of blank per sheet=24  
 Total area of single product=  $3000mm^2$   
 Now for 24 product=  $3000 \times 24$   
 $= 72000mm^2$  For  
 utilization of sheet Utilization of  
 sheet =  $(72000/102.5 \times 10^3) \times 100$   
 $70.24\%$  =

#### IV. FINITE ELEMENT ANALYSIS

##### Cad Modelling

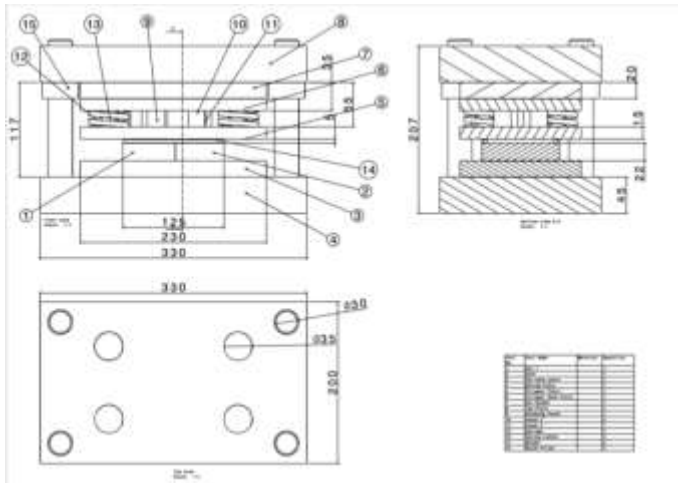

Fig 01: Assembly of Progressive Die

##### Solid Modelling

NX is a multi-use, multi-platform CAD software suit. NX also called as Unigraphics is 3D model developing software. It is most user friendly software.

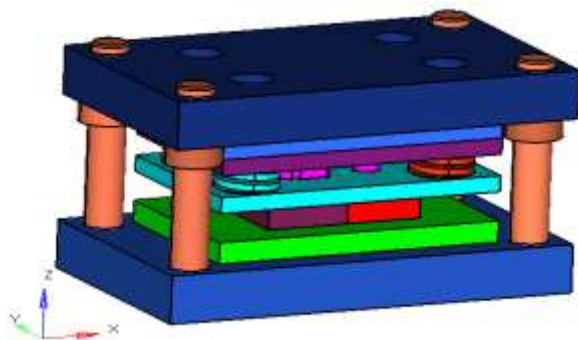

Fig 2: 3D model of progressive die

##### Spring Modelling

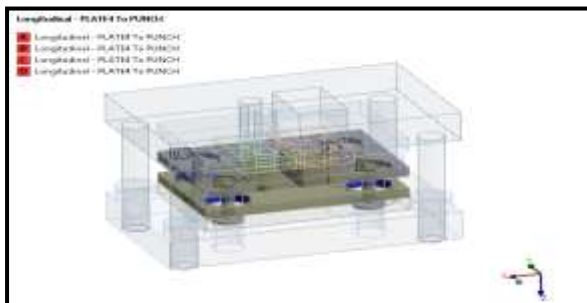

Fig 3: Spring modelling using Ansys connection tool

##### Model Meshing

No. of Nodes = 3,67,437

No. of Elements = 2,26,883

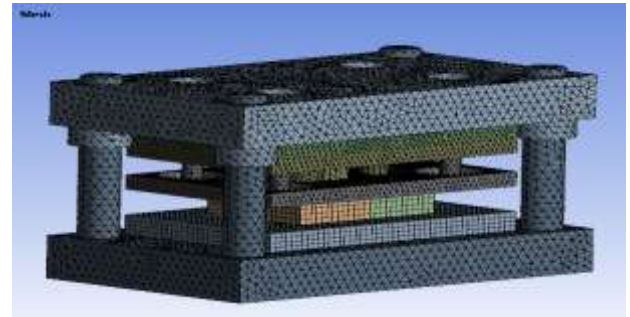

Fig 4: Meshed model as whole assembly

##### Modal Analysis of an assembly

- The boundary conditions applied to the assembly during modal analysis is frictionless support.
- X-direction displacement is fixed at supports.

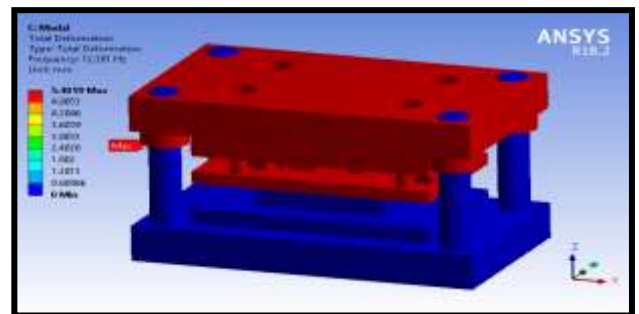

Fig 5: 1<sup>st</sup> frequency

- The 1<sup>st</sup> natural frequency is 12.38 Hz.
- When the operating frequency 12 Hz coincides with this frequency, resonance will occur and shaft may fail during twisting.

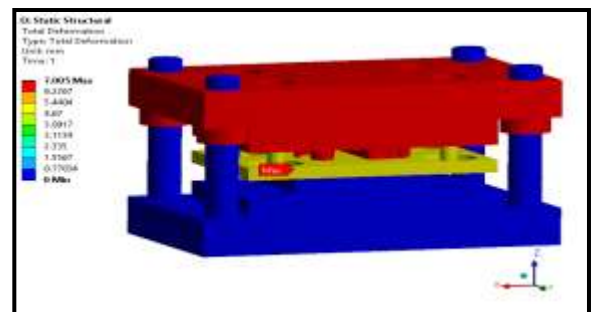

Fig 6: Displacement of assembly



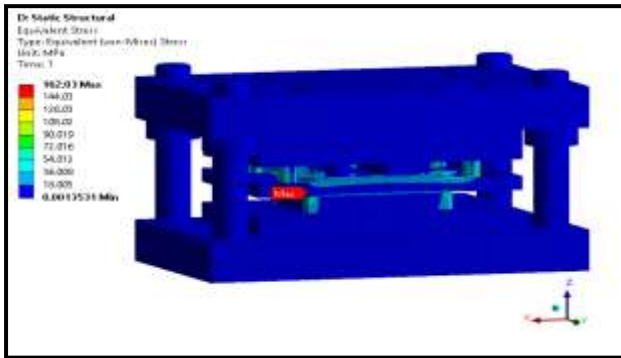

Fig 7: Von Misses Stresses generated

**V. RESULTS AND DISCUSSIONS**

We have analyzed Von Misses stresses with help of ANSYS. After comparing results, it is concluded design is safe.

Modes	Natural Frequency(Hz)	Result
1	12.38	No Resonance
2	119.6	No Resonance
3	143.91	No Resonance
4	404.59	No Resonance
5	497.07	No Resonance

Table 01: Modal Analysis Results

Sr. No	Parameters	Von Misses Stress (Mpa)	Yield Stress (Mpa)	Results
1	Die	162	827	Within Limit
2		107	370	
3		55	370	
4	Punch	140	827	Within Limit
5		13	370	
6		14	370	

Table 02: Structural analysis results

Here we calculated all permissible stresses which are in limit of standard stress of material used. Thus the design is safe.

The observations taken for 1minute, from that it is observed that for 1 minute the parts produced are 6 in number and for 1 hour parts produced are 360 in number.

**VI. CONCLUSIONS**

- From the results obtained from modal analysis we concluded that the vibrations on the die are bearable and there is no formation of resonance
- From the results obtained from structural analysis we concluded that the equivalent stresses acting on the assembly are within limit and thus design is safe for operations
- From the experimental results we obtained that time required for operation is 50 % less than old time. Also production rate obtained is 50% increased than old
- So the aim of designing progressive die with factors productivity, cost reduction, product quality is achieved.

**REFERENCES**

[1]. Prakash H. Joshi, Press tolols design And Construction, A. H. Wheeler and Co. Ltd., 411, Surya Kiran, K. G. Marg, New Delhi.

[2]. Ivana Shcy, Handbook of Die Design, 2nd edition Mc Grawth-Hill, 2006.

[3]. Gashaw Desie1 and Yonas Mitiku Degu2 1, 2, School of Mechanical and Industrial Engineering, Bahir Dar Institute of Technology Bahir Dar University, Bahir Dar, Ethiopia ,“ Progressive Die Design for Self Explosive Reactive Armor Holder (Case Study at Bishoftu Motorization-Industry-Ethiopia)”,The International Journal Of Engineering And Science (IJES) ISSN (e): 2319 – 1813 ISSN (p): 2319 – 1805.

[4] Taylan Altan, Metal Forming Hand book, Schuler, Berlin Heidelberg, 1998.

[5] Ch. Mastanamma1, K. Prasad Rao2, Dr. M.Venkateshwara Rao3, “Design and Analysis of Progressive die”, Vol.1, Issue 6, Aug. 2012 IJERA.

[6] Jyothi Bhaskar1, G Sathya Prakash2, “Die design and analysis of progressive tool for can lid lever” International Journal of Research in Engineering & Advanced Technology, Volume 1, Issue 4, Aug-Sept, 2018.