

HAND GESTURE BASED CAMERA MONITORING SYSTEM USING RASPBERRY PI

MARELLA NAGENDRA BABU¹, P.MURALI KRISHNA²

²Professor, Dept. of Electronics and Communication Engineering, SKU College of Engineering and Technology, Anantapuramu, Andhra Pradesh, India.

Abstract - Now a day's gesture control of appliances is increasing. We can thus create a gesture movements for camera monitoring and household applications, etc. In this hand gesture movements system the password is set with the predefined gestures by the user itself into the devices. Then a camera is used to capture the gesture from user. These gestures are compared with the previously defined gestures and if they occur to be same then the output produced must unlock or movements appliance via camera monitoring, door locks, etc. Here the image processing algorithms must capture the hand gestures from camera and compare it with the database gesture image. If they match then the gesture password is true or else it is false. This can also be integrated into mobile phones. Upon matching of the gestures the wireless signal via sent to the lock through nRF24l01. The gesture upon receiving the signal the micro controller movements itself. Here we are not using any remote to move the camera in all directions and hence there is no problem of handling the ir remote. Here if this transmitter signal system is used for staff room camera, then we can connect the receiver system with class room camera so that if the hand gesture captured by the transmitter camera and transmit the signals through nRF24l01. The receiver system receives signals based on signals the class room camera moves.

Key Words: Raspberry pi, Arduino Uno, Pi Camera, ESP-CAM, Servo, nRF24L01 Transceiver

1. INTRODUCTION

The basic intention of developing this new system of hand gesture based camera monitoring system using raspberry pi is to avoid use of external sensors, connecting bands and remotes. Gesture is nothing but a action of hands or any other human body part which are composed to accentuate speech. Generally Gesture formed by the movements of hands and face. There are mainly two types are gestures. In that dynamic and static gesture. Dynamic gesture means real time hand movements will there based on that movement camera capture. Static gesture means is not real time capture and compare.

Here, this system is to control the camera movements based on the hand gesture the camera will place where we want to monitor the place. In this system the camera place at the class room and master system at the control room.

We are using hand gesture to move the camera in different direction in the prewise system camera will rotate continuously they can stop the rotation using of remote but in our system whenever we want stop the rotation we can stop by using of simple hand gesture without any external hardware I used components in this system are companion computer like raspberry pi, low cost and easy to interface pi camera, for live video streaming camera is ESP32-CAM, for gesture data transmission and reception used nRF24l01 this will transfer and receive data nearly 500 meters.

2. Proposed system

The system design is two modules one is Master module this module will place master room. Master module will capture the gesture and sends to class module. Class module placed in the class room in this class module one Arduino and camera. Camera movements controlled by the servo motors up and down, right and left.

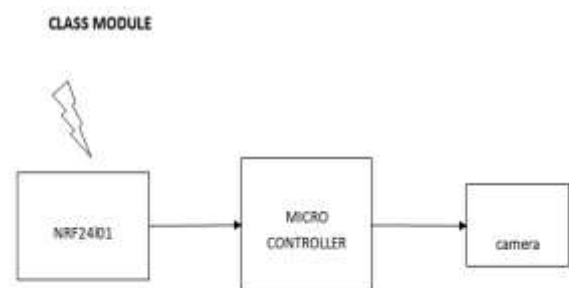

Fig-1: Block diagram of Class Module

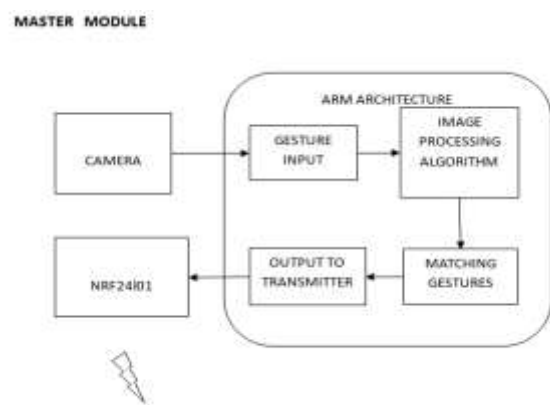

Fig-2: Block diagram of Master Module

2.1 Master Module

The Master Module placed in the master room from there hand gestures are detected by using of companion computer like raspberry pi and pi camera after detecting of hand gesture send data through wireless module nRF24L01 which is used for long range .The frequency band at 2.400 - 2.4835GHz. It will interface to microcontroller using SPI communication.

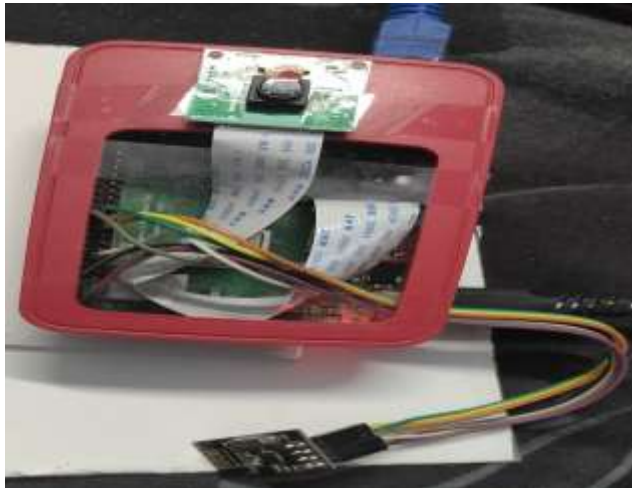

Fig-3: Master Module

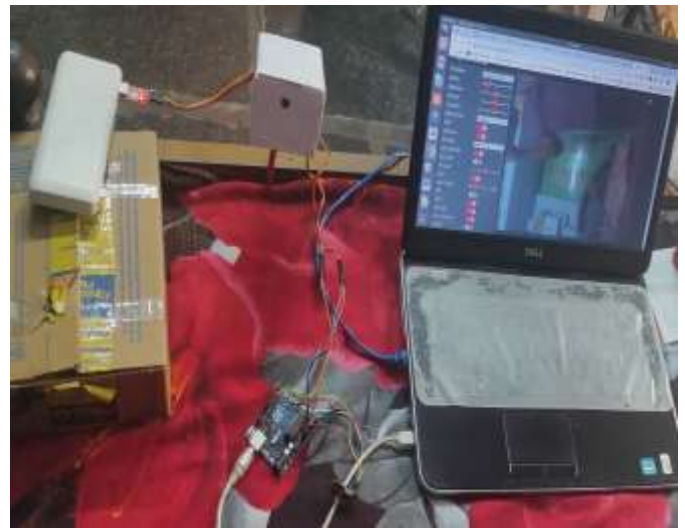

Fig-5 Class Module

2.3 ESP32-CAM

ESP32-CAM is a small size camera and low cost. It has so many features in built face recognition and SD card slot to store the captured images. There is disadvantage in this module there is usb port to upload the program. We have to upload program by using of FTDI module.

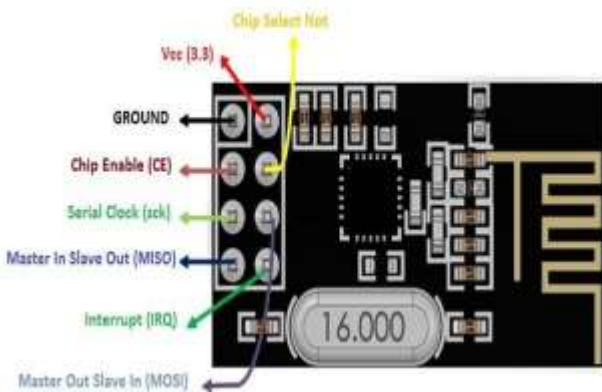

Fig-4: nRF24L01 Transceiver

2.2 Class Module

Class module consists of nRF24L01 acts as a receiver, Arduino uno it as a microcontroller to process the data, servo motor to rotate the camera and ESP32-CAM is used for the live video streaming and face recognition system Master Module has a send data through transmitter and Class Module receive the data from receiver and process the through Arduino uno and based on that servo motor with camera rotate and monitor the class of each and every student



Fig-6: ESP32-CAM

3. Flowchart

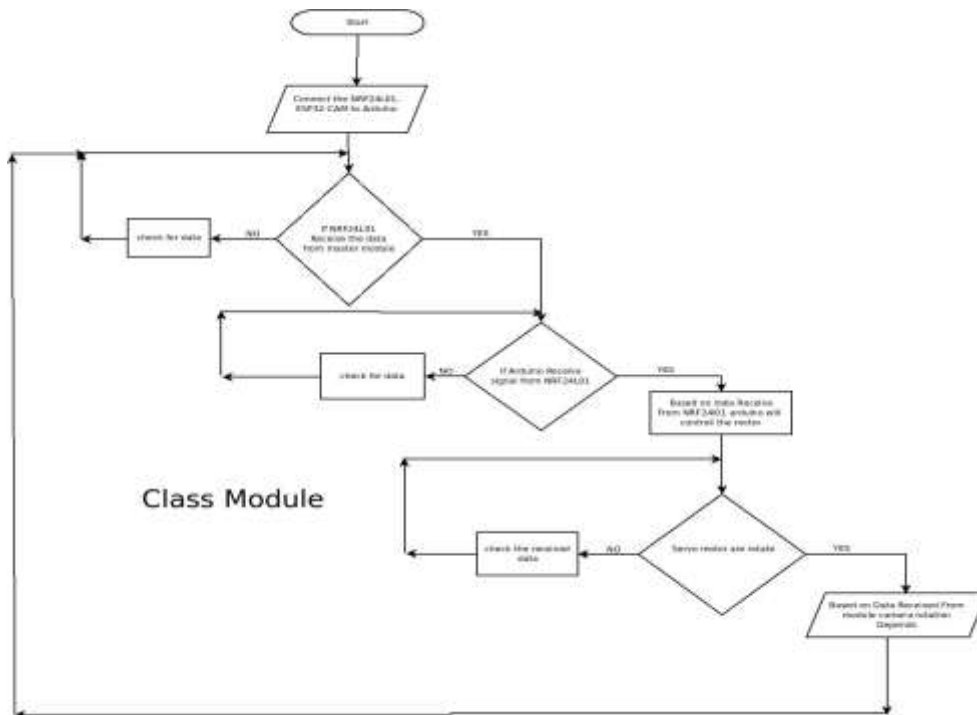

Fig-7: Flowchart for Class Module

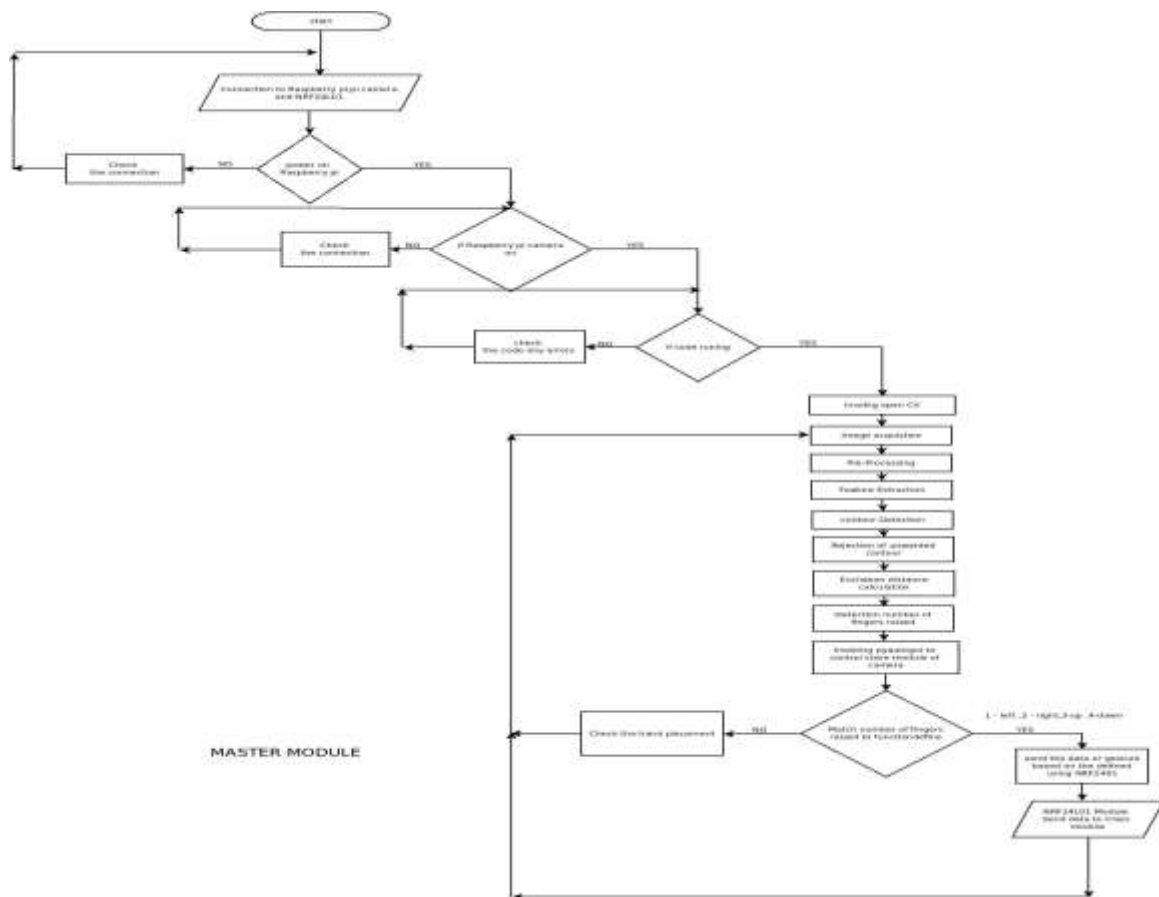

Fig-8: Flowchart for Master Module

4. Applications

Gesture based recognition system can be used to monitor employees in offices.

Gesture based system can be used to operate home appliances remotely

Gesture based recognition can be used to control robots to do risk involved activities such as bomb disposal and fire accidents

5. Results

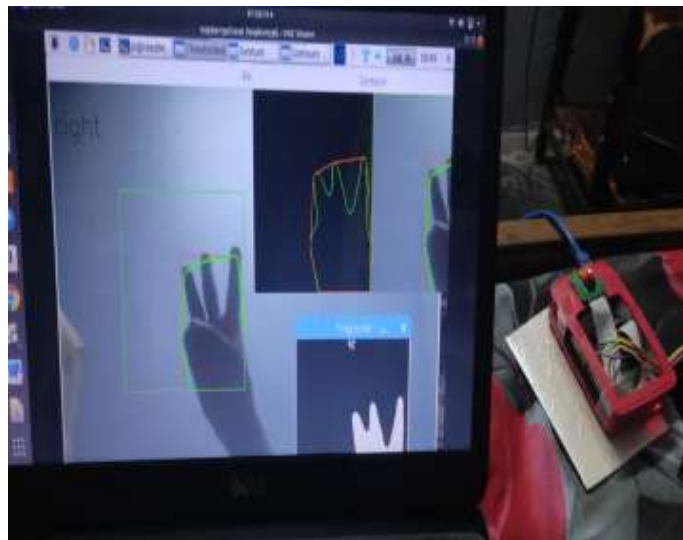

Fig-9: Camera Right turn Gesture

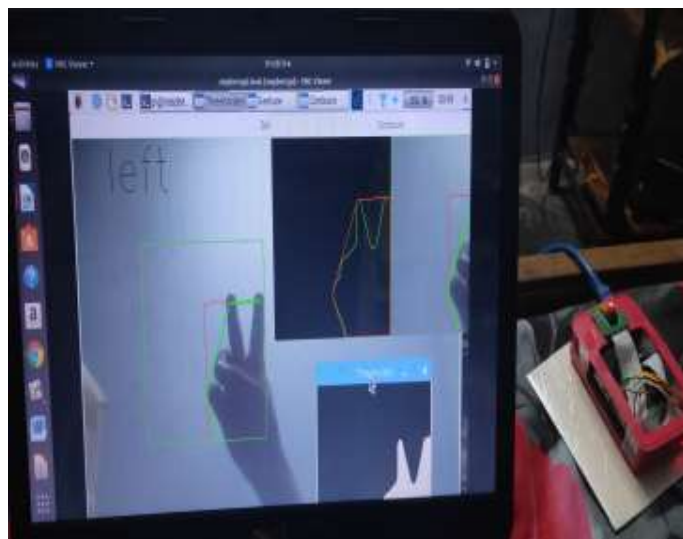

Fig- 10: Camera Left turn Gesture

6. Gesture Action Table

NO OF FINGERS	ACTION PERFORMED
2	camera turn left position
3	camera turn right position
4	camera move up position
5	camera move down position

Table1: Gesture Action Table

7. Conclusion

The objective of this project is to develop such a system which will help monitoring classrooms effectively and recognize the face of students and give their details. Based on the number of fingers show to raspberry pi camera specific type of action is triggered and the camera in classroom is moved accordingly and then the facial recognition is done

8. Reference

- [1] Jyoti Jadhav and Prashant Avhad," Hand Gesture Based Home Appliances Control System", IRJET, 2017
- [2] Salman Shaikh, Raghav Gupta, Imran Shaikh and Jay Borade "Hand Gesture Recognition Using Open CV",IJARCCE, 2016
- [3] Ali A. Abed and Sarah A. Rahman," Python-based Raspberry Pi for Hand Gesture Recognition", IJCA, 2017
- [4]<https://randomnerdtutorials.com/esp32-cam-video-streaming-face-recognition-arduino-ide/>
- [5]http://invent.module143.com/daskal_tutorial/raspberry-pi-3-wireless-pi-to-arduino-communication-with-nrf24l01/