

## Affordable Rehabilitation using GFRG Panels

**Bijimol Joseph, Amal Joe Abraham, Jowin Mathew John, Rahul P R, Vyshagh M**

*Assistant Professor, Department of Civil Engineering, VJCET, Kerala, India.*

*UG Student, Department of Civil Engineering, VJCET, Kerala, India.*

\*\*\*

**Abstract** — Affordable rehabilitation possibility is one of the most sought after things after a major calamity. Kerala is currently facing such a need. Kerala is in the aftermath of an unprecedented flood havoc. The calamity has caused immeasurable misery and devastation. Around thousands of homes were totally destroyed and many more were partially damaged. At present Kerala is going through the phase of rebuilding. 'Rebuild Kerala' is a Kerala State Government initiative in consultation with KPMG, for crowd funding of projects envisaged for rebuilding Kerala. The virtual platform provides an opportunity for all willing individuals and institutions to contribute to the rebuilding measures. On the houses rebuilding initiative, which is a priority area, Pre- Fabrication is planned to be used wherever possible and agencies executing the same will be those empaneled by BMTPC (Building Material Technology Promotion Cell of Government of India) ensuring reliability of the structure. At this time, not only there is a need to construct these houses rapidly, they have to be made affordable and sustainable considering shortage of funds and local resources. In this project we are studying the affordability aspect of GFRG panels over conventional materials in rehabilitation.

**Key Words:** Affordable Rehabilitation, Rebuild Kerala, GFRG

### I. INTRODUCTION

GFRG panels are comparatively affordable and rapid form of construction. The panels are currently manufactured nearby at FACT-RCF BUILDING PRODUCTS,

Ambalamedu and hence readily available. The major raw material, Gypsum is obtained as a by-product from fertilizer manufacturing unit at FACT Udyogamandal Kochi. Hence it is also a green building material. These panels are manufactured with dimensions 12m length and 3m height and a thickness of 124mm. These panels contain cavities between flanges and rib which can be filled with RCC for additional strength.

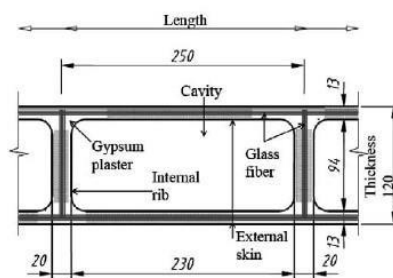

**Fig -1:** Cross section of GFRG panel

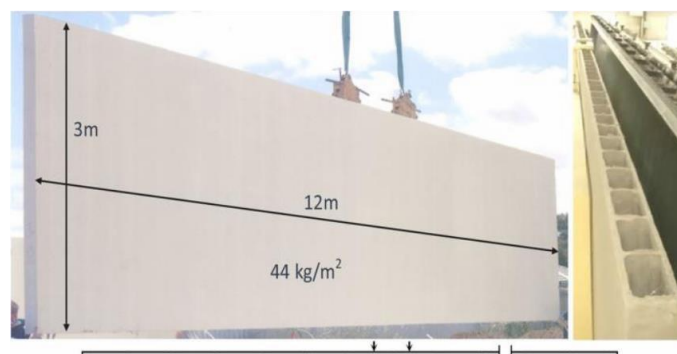

**Fig -2:** Elevation and cross – section details of GFRG panel

## 2. OBJECTIVES

- To determine the affordability and feasibility conditions of GFRG panels for rehabilitation purposes
- To compare GFRG construction with conventional methods.
- To analyze methods by which cost could be reduced for rehabilitation.

[2004]Y.-F. Wu; in his paper discusses about the structural behavior and design aspects of GFRG panels. This method was developed in Australia in early 1990's and was subsequently adopted in any Asian countries. GFRG panels were approved to be eligible for carbon credits by World Bank under Kyoto protocol

**Table 1.** Strength characteristics of GFRG panels

Weight- light weight	40 Kg/ sqm
Axial load capacity	160 kN/m{ 16 tons/ m}
Compressive strength	73.2 Kg/cm <sup>2</sup>
Unit Shear strength	50.90 kN/m
Flexural strength	21.25 kg/cm <sup>2</sup>
Tensile Strength	35 KN/ m
Ductility	4
Fire resistance 4 hr rating	withstood 700-1000 °C
Thermal conductivity	0.617
Thermal Resistance R	0.36 K/W
"U "Value	2.85W/M <sup>2</sup> K
Elastic Modulus	3000-6000Mpa
Sound transmission{STC}	40
Water absorption	< 5%

## 3. LITERATURE REVIEW

[2018] K. Alagusankareswari et al; in this paper studied about the change in physical and mechanical characteristics of empty panel using different experiments. The paper mainly deals with properties like Water absorption rate, Vertical Load bearing capacity, Flexural strength of empty panel, including some physical properties. They can be used in the areas which have been struck with calamities and for restoring the lifeline of the area rapidly. This is the major aspect considered for the purpose of rehabilitation. If a common plan is adopted for mass housing projects, the panels could be cut in similar sizes thus reducing time for manufacturing.

[2017]Shinto Paul et al., this paper gives study on GFRG panel. GFRG buildings can completely avoid cement plastering, and uses much less quantities of steel, cement sand and water compared to conventional buildings. Painting and plastering is mostly skipped for mass housing projects by government mainly because it consumes more time and involves more expenses in terms of resources and skilled labor. GFRG panel contain less carbon footprint and is a sustainable product which has been manufactured from industrial waste gypsum contributing to sustainable development. Study on its use as a material for super structures and mass housing.

[2016]Mohamed Said et al; in this paper, the cost analysis for GFRG panels is done. It was found that direct cost involved 6 major categories. These are Panel itself, Accessories for supporting or transporting panels, Crane cost for erection of walls, Labour and RCC cost, and transporting cost. The panel cost is calculated in meter square. According to the paper GFRG panels saves a lot in terms of construction time which reflects in terms of total construction cost. For this proper planning has to be made before making the building plan to make use of its advantages.

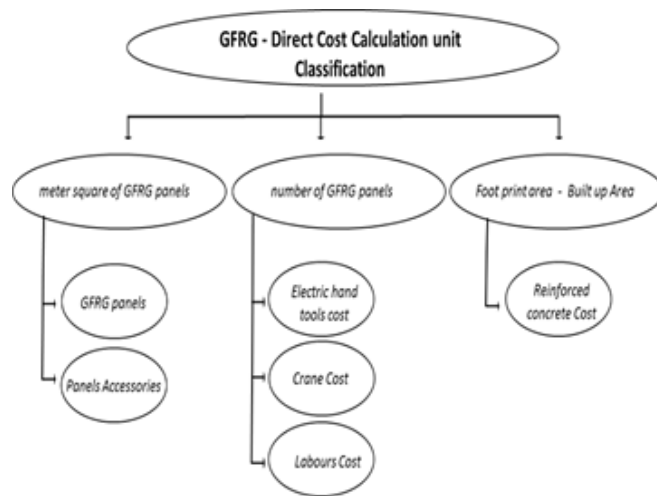

**Fig -3:** Cost calculation categorization of GFRG panels

[2015] K. Kalaipriya et al., in this paper a comparison of estimate of a GFRG wall paneled house with hat of conventional building materials is carried out.

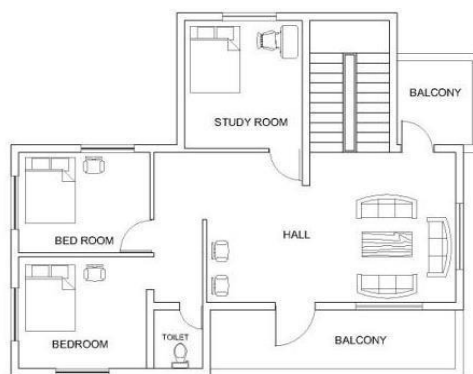

**Fig -4:** First floor plan



**Fig 5 Ground floor plan**

Quantity of Panels Required

1. For Wall - 346.45 sq.m
2. For Slab - 240.12 sq.m

Total Panels required - 586.57 sq.m

Cost for Panels - 5.86 Lakhs

Concrete Work Estimation - 8.92 Lakhs

Electrical work 8% of civil work - Rs. 133040

Plumbing work 5% of civil work - Rs. 83150

For steel work 6% of civil work - Rs. 99780

Total - 17.95 Lakhs

This cost is comparatively less than buildings made using conventional methods of construction

### 3. PLANT VISIT

The raw material, which is gypsum is obtained as a by- product from FACT, Udyogamandal and is piled in an open area. It is collected and finely powdered and impurities are removed before manufacturing. After pouring gypsum mortar into the moulds, glass fibres are spreaded in both the surfaces as layers and is compacted. This provides load bearing characteristics to the panels. These walls are kept in an aerated room for drying, for about 24 hours. The speed of manufacturing it's kept in such a manner that one panel comes out of the plant every hour. Samples are collected from each batch to test structural aspects and to ensure quality.

### 4. STRUCTURAL ASPECTS OF GFRG

Each panel is erected at the same level and will be supported by lateral props in level, plumb and secure in position. Once wall panels are erected along with doors and window frames, fixed in position using clamps and with concrete infill in cavities on either side. RCC Lintels are to be provided by cutting open external flange along with required shuttering and support.

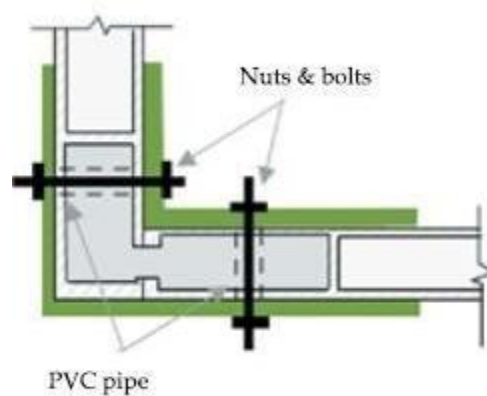

**Fig -6:** 'L' joint in wall-section

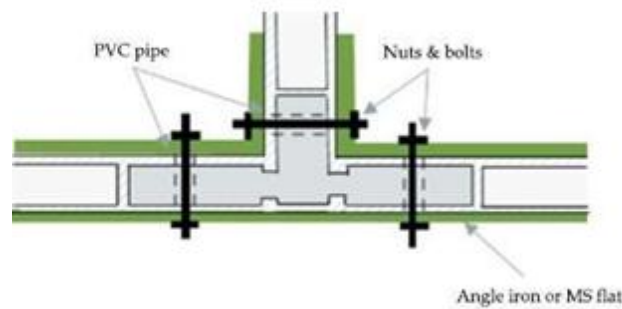

Fig -7: 'T'- joint design

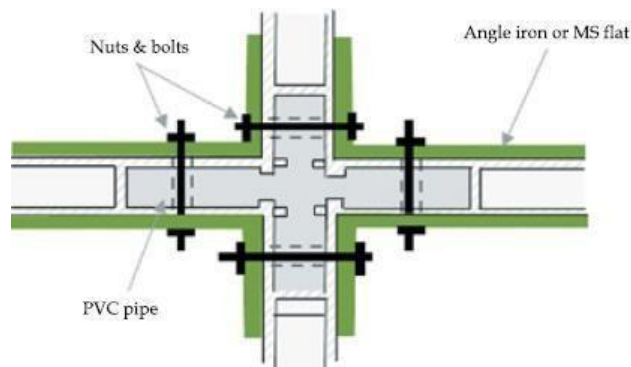

Fig -8: 'Four-way' Joint design in GFRG

## 5. METHODS OF COST REDUCTION

Proper planning is required prior to cutting off panels, from the part of the consumer.

- The building plan can be made considering dimensions of the panel, in order to reduce wastage. Both sides of the panel are level and smooth, so there is no need for further plastering.
- Since the panel is hollow, laying electrical cables and plumbing works are easier.
- Same panels could also be used as load bearing slab and stairs so that there is further reduction in cost.
- The panels are just 12.4 cm thick thus building will have more carpet area available compared to conventional materials.
- Since the panels are hollow, there are found to have better thermal performance. It could be improved further by using other filling materials.

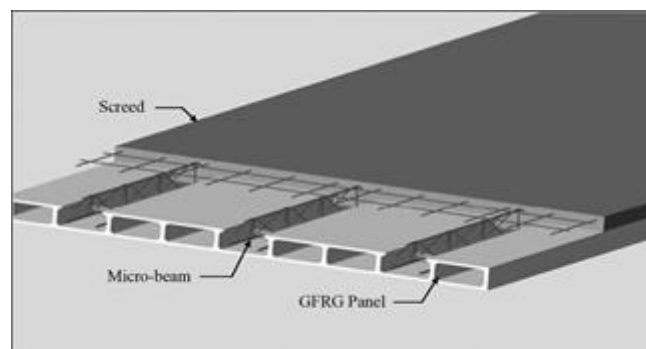

Fig -9: GFRG panels used as roof slabs

## 6. CONCLUSIONS

From the analysis it is clear that GFRG panels can play a major part in rehabilitation activities as the cost of construction reduces for mass housing projects. Strengthening of GFRG panels could be improved by using RCC in cavities or any other materials could be filled for improving other properties like thermal insulation. However, for constructing using unfilled GFRG panes, proper waterproofing is necessary to ensure that there is no loss of structural integrity in highly flooded regions.

Using GFRG construction, there is a significant reduction in manpower, cost and time of construction. It also helps reduce exploitation of river sand, water etc., which is also very expensive these days. Reinforcement bars are inserted at intervals in the concrete filling and this improves its vertical and lateral load resistances. So it can protect lives and properties as these buildings are more resistant to natural disasters like earthquake, cyclone and fire.

## REFERENCES

- [1] K Alagusankarshwari, Jenitha G, S Sastha, Arumugapandi, "Experimental study on empty glass fibre reinforced gypsum panel" *Indian.J.Sci.Res*, vol. 17(2), pp. 217–220, 2018.
- [2] Maganti Janardhana, A. Meher Prasad, Devdas Menon, *Studies on the behavior of Glass fiber reinforced gypsum wall panels*, January 2006.
- [3] Wu YF, Dare MP (2004) Axial and shear behavior of glass fiber reinforced gypsum wall panels, *Volume 8(6)*, pp569–678
- [4] ShintoPaul, Devdas Menon Meher Prasad, P. Gopinathan "sustainable, Rapid and Affordable Mass Housing Using 'GFRG' Panels" *International Journal of Advances in Mechanical and Civil Engineering*, Volume-4, Issue-3, pp135-139, 2017
- [5] Mohamed Said Meselhy Elsaheed "Cost Model For Using Glass Fibre Reinforced Gypsum System (GFRG)". Vol.4, No.3, pp.33-47, June 2016
- [6] K.Kalaipriya, R.Jayanthi, "Comparative Study On Estimation Of Wall Panel System With Conventional Building Works In Construction Industry" *International Journal of Science and Engineering Research*, Volume 3 Issue 6, June 2015.