

# SD Card Based File System for CNC Machine using TMS320F2837xD Processor

Deepali D. Dhikale<sup>1</sup>, Prof. Dr. Sunil S. Morade<sup>2</sup>

<sup>1</sup>Department of Electronics & Telecommunication, K.K.Wagh Institute of Engineering, Maharashtra, India

<sup>2</sup>Department of Electronics & Telecommunication, K.K.Wagh Institute of Engineering, Maharashtra, India

\*\*\*

**Abstract** - The main objective of this paper is to implement SD card based file handling system for CNC machine. CNC machine uses numerical data to control a machine. The system uses dual core DSP processor with c28xx core. Implementation of file system for CNC machine reduces the file processing and tool processing time to a great extent. The dual core DSP processor is interface with the SD card for large storage of data in CNC machine. The TMS320F2837xD control card has SD card slot so file system can be designed for CNC system. The algorithm for file handling for CNC machine is implemented using Texas Instrument Code Composer Studio IDE environment. The another important task of this experiment is to convert the .CNC file into the machine acceptable format for the tool processing and file processing in the CNC machine.

**Key Words:** CNC, FAT32 file system, SD card, CCS, controlcard F28377D

## 1. INTRODUCTION

The control of a machine tool by using stored information through the computer is known as computer numerically controlled. A CNC system consists of three basic components such as part program, machine control unit and machine tool. The part program is a set of commands followed by the machine tool. The machine control unit is a microcomputer that stores the program and executes the commands into actions by the machine tool and it decides the feed, acceleration time and plunge for CNC machine. The machine tool could be one of the following such as lathe, milling machine, laser, plasma, coordinate measuring machine etc. The main objective of this system is to design SD card based FAT32 file system for CNC machine. The Delfino F2837xD is a 32-bit floating-point microcontroller unit (MCU) designed for advanced closed-loop control applications such as industrial motor drives, solar inverters, electrical vehicles, sensing and signal processing. As the mathematical calculations required for numerical data goes on increasing the processing time for CNC will also increases. To reduce the processing time of machine the use of DSP processor in CNC system has been increased tremendously. The processor used in this system is TMS320F28377D which is a dual core DSP processor. The control card provided by Texas Instrument has SD card port to store the data and to reuse it in the future. CNC machine requires a mass storage of data files which are further processed by the CNC machine. To support the file management system we requires SD card to store the data files. This data is processed by the processor to execute the various operations such as turning, rolling,

grinding, drilling etc. To transfer these files to SD card, SD card module is interfaced with the TMS320f28377D dual core processor. It requires to develop a C Program to implement FAT file handling and management for the SD card. Communication with an SD card can be done in two modes such as SD mode and SPI mode. However we will work with the SPI mode and communicate with it using the SPI protocol. So the communication between processor and SD card is done using SPI protocol.

## 2. SYSTEM OVERVIEW

The overview of SD card and file system are given below:

### 2.1 SD CARD

The Secure Digital Card (SD card) is flash-based memory card and it is specially designed to meet the security, capacity, performance and environmental requirements of audio and video consumer electronic devices. SD is an abbreviation of Secure Digital and micro SD cards are sometimes referred to as SD or micro SD. The cards are used in mobile phones and other mobile devices. The copyright protection mechanism of SD card complies with the security of the SDMI standard and is faster and capable of higher Memory capacity. There are two modes to communicate with SD card i.e. SD mode and SPI mode.

### 2.2 FILE SYSTEM

FAT stands for File Allocation Table. It is computer file system architecture. The various file systems for the various devices such as NTFS, FAT12, UDF, exFAT, FAT16, FAT32. This File architecture system is supported by all the compatible devices such as personal computers and many mobile devices as well as various operating systems. FAT32 is the latest version of the FAT file system. It was introduced in 1996 for Windows 95 users. FAT32 supports basic drive sizes up to 2 TB or even as high as 16 TB. The FAT file system is simple and robust. It is a well-suited format for data exchange between computers and different devices. FAT32 file systems are used for SD Card, USB flash Devices, Memory Cards and various portable embedded devices. The card capacity is depend on which file system is used to store data. Plain or conventional SD cards store up to 2GB using FAT12 and FAT16 file system. High capacity SD cards store between 2GB to 32GB using FAT32 file system and extended capacity SD cards store between 32GB to 2TB using exFAT file system. The various file functions of Fat32 File system are as follows:

**Table 1:**FAT32 file function

Fat32 File Function	Description
f open	Open/Create a file
f close	Close an open file
f read	Read data
f write	Write data
f seek	Move read/write pointer, Expand size
f gets	Read a string
f printf	Write a formatted string
f eof	Test for end-of-file
f opendir	Open a directory
f closedir	Close an open directory

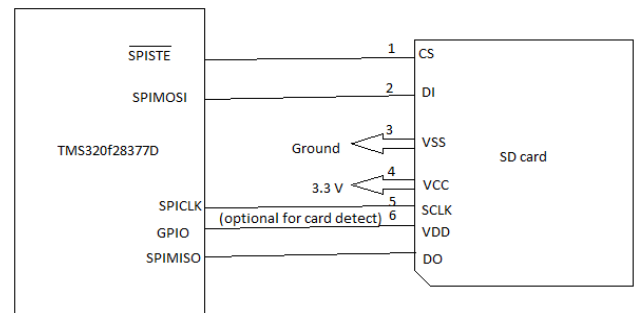

**Fig.2** SD card interfacing with processor

**3. SYSTEM DESIGN**

The Delfino F28377D controlcard from Texas Instruments (TI) provides a way to learn and experiment with the F2837x device family within TI's C2000 family of microcontrollers (MCUs).The high performance processor is located on the controlcard. This processor has the SD card slot so that a file to the machine can be given by the SD card as shown in Fig.1The internal system will process the file according to the program written and then convert it into the .kou file with some changes in original file.FAT-32 file system includes various functions such as creating the new file into SD card, copy the contents of the file, reading the file, write into the file.

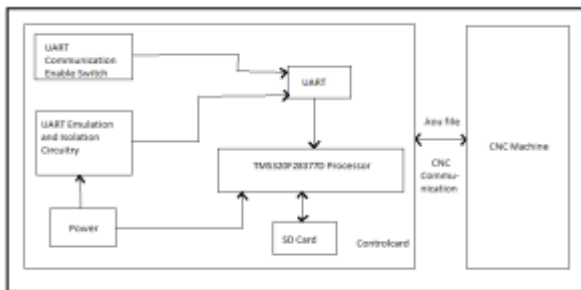

**Fig.1** Block diagram of system

Fig.2 shows the SD card interfacing with the TMS320F28377D processor. Communication with an SD card can be done using two modes the SD mode and the SPI mode. The communication between processor and SD card is done using SPI protocol as shown in fig.2. There are different signals from host to SD card such as CS, CLK, MOSI, MISO. The CS of the F28377D is configured as a GPIO output and pulled high and low manually to meet timing specifications of the SD card. CS (chip select) is the host-to-card chip select signal. An active low signal that selects a particular SD card, CLK i.e. host-to-card clock signal, MOSI i.e. (Master Out Slave In) host-to-card single-bit data signal, MISO i.e. (Master In Slave Out) Card-to-host single-bit data signal.

**3.1 HARDWARE DESIGN**

The F28377D controlcard supports USB host/device connectivity. The F28377D Experimenter's Kit is designed to be powered via USB. The control card development kit is based on the Delfino F28377D MCU which provides 800MIPS of total system performance between dual 200MHz C28x CPUs and dual 200MHz real-time-control co-processors (CLA). The SD card module is interface with the controlcard for the mass storage of .CNC files. These files are further used for deciding the various actions of CNC machine in the tool processing. The main objective of this experiment is to implement file management system for CNC machine using the SD card and hence increase memory size to hold the large data of .CNC file. The system employ dual core C28x DSP processor (TMS320F28377D) for file handling and file management system as well as performs various operations of CNC machine. The dual real-time control subsystems are based on TI's 32-bit C28x floating-point CPUs, which provide 200 MHz of signal processing performance in each core. For the fast execution of algorithms with trigonometric operations common in transforms and torque loop calculations it uses TMU accelerator and the VCU accelerator, which reduces the time for complex math operations common in encoded applications. The system uses Embedded C programming in the Code composer studio (CCS) IDE environment. The important task of the project or this system is to convert the .CNC file into the machine acceptable format for the tool processing in the CNC machine. The File handling and management system for the CNC machine is prepared by using SD card interface with the controlcard using SPI communication.



**Fig.3** F28377D Texas Instruments (TI's) Control card

### 3.2 SOFTWARE DESIGN

The Text file in the Format of ASCII is selected from the SD card and then further processed according to the algorithm as follows:

1. Select .txt or .nc or .U00 file in the ASCII format.
2. For the tool processing, choose the acceleration time & maximum feed for the tool processing.
3. By calculating feed and acceleration rate create the tool.U00 and tool1.U00 files.
4. To create nos.abc file which shows the line no. of G-code which are changed due to calculations.
5. To generate the .kou file with change in feed value and Emin distance for tool processing.

This processing and coding is done by using C software Texas Instruments (TI) Code Composer Studio (CCS). The FAT32 file system is designed for SD card using dual core F28377D processor. Using FAT32, files from SD card can be read, write, copied and newly created according to algorithm as shown in fig.4

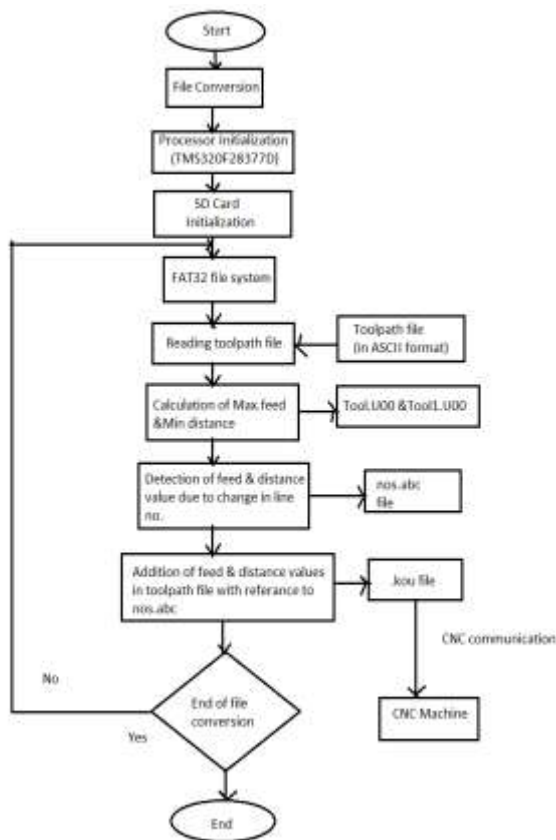

Fig.4 File conversion algorithm

### 4. EXPERIMENTAL RESULTS

Using TI's controlcard the different file commands of FAT32 file system for SD card are designed. The command execution for SD card files is done using the serial terminal of CCS. Code Composer Studio has its own terminal to serially transmit and receive the data. Using the 'ls' command of FAT32 file system, the list of files in SD card with their date of creation and file size can be viewed. Using 'cat' command any file from SD card can be read and displayed on serial terminal. The 'copy' command will read the file from SD card. File 'create' command creates the new file into the SD card. The 'help' command shows the list of FAT32 file system commands for different file operations. Using the 'cd' command the directory in SD card can be changed. In this way all these FAT32 file system commands are designed for SD card using TMS320F28377D dual core DSP processor. The experimental results are shown in figure 5.

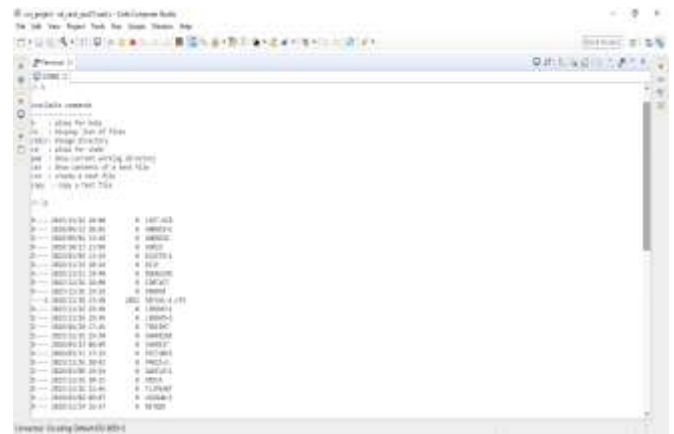

Fig.5 Output results on serial terminal window

### 5. CONCLUSION

In this project the FAT32 file system and dual core DSP processor TMS320F28377D are studied. Also studied what is CNC machine, how it works, what are its inputs and outputs, need of file conversion and different stages of file conversion in CNC machine. Files from SD card are read, Write, copy and newly created using FAT32 file system. This experiment eliminates the use of laptops and PC systems in CNC environment by using SD card. First the file from user is given to file conversion code and then this code optimizes feed and related parameters suitable for CNC machine and generate .kou file. If we give parameters given by user as it is then it may damage the CNC machine. The .kou file is stored in the SD Card is given to the CNC machine with required feed and acceleration rate for tool processing operations from user.

### REFERENCES

[1] F. Barbieri, R. P. S. Chandrasena, F. Shahnia, S. Rajakaruna and A. Ghosh, "Application notes and recommendations on using TMS320F28335 digital Signal Processor to control voltage source converters," 2014 Australasian Universities Power Engineering

Conference (AUPEC), Perth, WA, 2014, pp. 1-7 Ghosh, "Application notes and recommendations on using TMS320F28335

- [2] Y. Xin, "Hardware and Software Design between Microcontroller and Computer Based on USB Interface," 2014 Fifth International Conference on Intelligent Systems Design and Engineering Applications, Hunan, 2014, pp. 520-523. J. Clerk Maxwell, A Treatise on Electricity and Magnetism, 3rd ed., vol. 2. Oxford: Clarendon, 1892, pp.68-73.
- [3] O. Mahendra, D. Syamsi, A. Ramdan and M. Astrid, "Design and implementation of data storage system using USB flash drive in a microcontroller based data logger," 2015 International Conference on Automation, Cognitive Science, Optics, Micro Electro-Mechanical System, and Information Technology (ICACOMIT), Bandung, 2015, pp. 5862.
- [4] H. Fu, C. Li and Y. Fu, "A Parallel CNC System Architecture Based on Symmetric Multi-processor," 2016 Sixth International Conference on Instrumentation & Measurement, Computer, Communication and Control (IMCCC), Harbin, 2016, pp. 634-637
- [5] Mohammed Abdalla.A. Ali, Ahmed Mohamed.A. ELShaikh and Sharief F. Babiker, "Controlling the CNC Machine using Microcontroller to Manufacture PCB," Conference of Basic Sciences and Engineering Studies (SGCAC), 2016.
- [6] Code Composer Users Guide Literature Number: SPRU296 February 1999 by TI.
- [7] TMS320F2837xD Dual-Core Delfino Microcontrollers Technical Reference Manual.
- [8] F2837xD Workshop Workshop Guide and Lab Manual F2837xD-TTO by TI.
- [9] <http://www.ti.com/lit/ds/sprs439m/sprs439m.pdf>.
- [10] <http://www.ti.com>
- [11] [http://c2000.spectrumdigital.com/ezf28335/docs/ezds\\_pf28335c\\_techref.pdf](http://c2000.spectrumdigital.com/ezf28335/docs/ezds_pf28335c_techref.pdf).