

EFFECT OF DESIGN PARAMETERS ON LOAD CARRYING CAPACITY AND FATIGUE LIFE OF ANGULAR CONTACT BALL BEARING

Priya Tiwari¹, Samant Raghuvanshi²

¹M.E. Scholar, Department of Mechanical Engineering, Jabalpur Engineering College, Jabalpur, Madhya Pradesh, India

²Assistant Professor, Department of Mechanical Engineering, Jabalpur Engineering College, Jabalpur, Madhya Pradesh, India

Abstract -This article considers the parameters such as outer raceway curvature, number of balls and bearing material for determining the total deformation, equivalent (Von-Mises) stress, fatigue life and fatigue damage of 7008 CD/P4A angular contact ball bearing. The bearing is designed and analyzed using CATIA V5 and ANSYS 18 software respectively. The investigation consists of static structural and transient dynamic analysis. The effect of design parameters on the performance of bearing is studied using design of experiment with the help of MINITAB software. For mathematical calculation, hertz contact theory is used. The theoretical and ANSYS results are also compared and the outcomes are approximately the same.

Key Words : angular contact ball bearing, hertz contact theory, design of experiment, CATIA, ANSYS, MINITAB, total deformation, equivalent (Von-Mises) stress, fatigue life, fatigue damage.

1. INTRODUCTION

Rolling bearings are the crucial mechanical elements which are subjected to high speeds and concentrated contact loads. Therefore, bearing parameters should be analyzed in order to optimize the performance of the bearing. The present work is based on the static structural and transient dynamic analysis of 7008 CD/P4A angular contact ball bearing for analyzing the design parameters that influence the life and performance of ball bearing. The bearing is subjected to various working conditions such as radial load, axial load and rotational velocity. The models are based on different combinations of design parameters. The mathematical calculation is done using hertz contact theory in which calculation is based on the consideration of elliptical shape contact area. The ANSYS results are compared with theoretical results.

The emphasis is laid on analyzing the effect of these parameters on the performance of ball bearing using the concept of design of experiment. Design of experiment deals with planning analyzing and interpreting controlled lists to evaluate the factor that control the value of parameters. In this paper, this is carried out using Taguchi method with the help of MINITAB software. Taguchi method is a robust design method that optimizes the best levels of control factors by minimizing the variance and helps in prediction of the results.

1.1 Objectives

The objective of the present work is as follows:

- 1) To analyze single row 7008A angular contact ball bearing design models comprising of different combinations of parameters and determine total deformation, equivalent (Von-Mises) stress, fatigue life and fatigue damage.
- 2) To find the best design model under given conditions on the basis of results obtained with the help of Taguchi's design of experiment.

2. MATHEMATICAL MODEL

According to the hertz contact theory, it is assumed that an elliptical shape contact area is developed when a point contact occurs between two elastic solids subjected to load W . Then,

The curvature sum, $\sum \rho = \rho_{11} + \rho_{21} + \rho_{12} + \rho_{22}$

The curvature differences,

$$F(\rho) = (\rho_{11} - \rho_{12}) + (\rho_{21} - \rho_{22}) / \sum \rho$$

For outer raceway,

$$\rho_{11} = 1/r_{11} = 2/d_b;$$

$$\rho_{12} = 1/r_{12} = 2/d_b;$$

$$\rho_{21} = -1/r_{21} = -(2/d_b) (\gamma/1 + \gamma);$$

$$\rho_{22} = -1/r_{22} = -1/f_0 d_b ;$$

where $\gamma = d_b(\cos \alpha_0)/d_m$

$f_0 =$ curvature ratio.

$d_m =$ Pitch radius.

$\alpha_0 =$ Contact angle.

Then, equivalent curvature radius is

$$R_x = \rho_{11} + \rho_{21}$$

$$R_y = \rho_{12} + \rho_{22}$$

Ellipticity ratio is

$$K = 1.0339(R_y/R_x)^{0.636}$$

The first complete elliptic integral is

$$F = 1.0003 + 0.5968/(R_y/R_x)$$

The second complete elliptic integral is

$$F = 1.5277 + 0.6023 \ln(R_y/R_x) \quad \dots\dots[2]$$

For combined load, load on each bearing ball is given by

$$Q = F_r/Z J_r(\epsilon) \cos \alpha = F_a/Z J_a(\epsilon) \sin \alpha \quad \dots\dots[11]$$

Where $Z =$ Number of balls

And $J_r(\epsilon), J_a(\epsilon)$ depends on ratio $F_r \tan \alpha / F_a$

The equivalent elastic modulus is given by

$$2/E' = 1 - \mu_1^2/E_1 + 1 - \mu_2^2/E_2$$

Then, deformation is given by

$$\delta = \delta^* (3Q/\sum \rho E')^{2/3} (\sum \rho/2)$$

where $\delta^* = 2F/\pi (\pi/2K^2E)^{1/3}$

also, $a = a^* (3Q/\sum \rho E')^{1/3}$

where $a^* = (2KE / \pi)^{1/3}$

$$b = b^* (3Q / \sum \rho E')^{1/3}$$

where $b^* = (2E / \pi K)^{1/3} \dots [2]$

The pressure within elliptical shape contact area is

$$P = P_{max} [1 - (x/b)^2 - (y/a)^2]^{1/2}$$

Where, $P_{max} = 3Q / 2\pi ab$

The Principle stresses are given by

$$\sigma_1 = \sigma_2 = \sigma_x = \sigma_y = - P_{max} [(1-x)\{1 - |z/a| \tan^{-1}(a/z)\} - \frac{1}{2}(z^2/a^2 + 1)]$$

$$\sigma_3 = \sigma_z = - P_{max} (z^2/a^2 + 1)^{-1} \dots [8]$$

The equivalent stress (Von-Mises) is given by

$$J = 1/12 [(\sigma_1 - \sigma_2)^2 + (\sigma_2 - \sigma_3)^2 + (\sigma_3 - \sigma_1)^2] = F^2/2 = S^2/3 \dots [12]$$

Where \sqrt{J} is defined as equivalent stress.

3. BEARING PARAMETER SELECTION

The bearing parameters to be considered for the analysis are outer raceway curvature, number of balls and material as described in the following table:

Table No. 1-Bearing Parameters

BEARING MATERIAL	Stainless steel	Aluminum Oxide	Zirconium Oxide
OUTER RACEWAY CURVATURE	0.53 d	0.55 d	0.54 d
NUMBER OF BALLS	12	15	18

4. DESIGN OF SINGLE ROW ANGULAR CONTACT BALL BEARING

Angular contact ball bearing comprises of four main parts namely outer race, inner race, rolling element (i.e., ball) and a retainer. Three dimensional modeling of 7008 CD/P4A angular contact ball bearing is done with the help of CATIA V5 software using following standard dimensions:

Table no. 2-Ball bearing specifications

ATTRIBUTES	VALUES
Inner Diameter (d)	40 mm
Outer Diameter (D)	68 mm
Pitch Circle Diameter (D _m)	54 mm
Initial Contact angle (α)	15°
Ball Diameter (d _w)	7.938 mm
Basic Dynamic Load Rating (C)	16.8 kN
Basic Static Load Rating (C ₀)	11 kN
Mass	0.19 kg
Attainable Speed	20,000 r/min
Material for Retainer	Manganese bronze

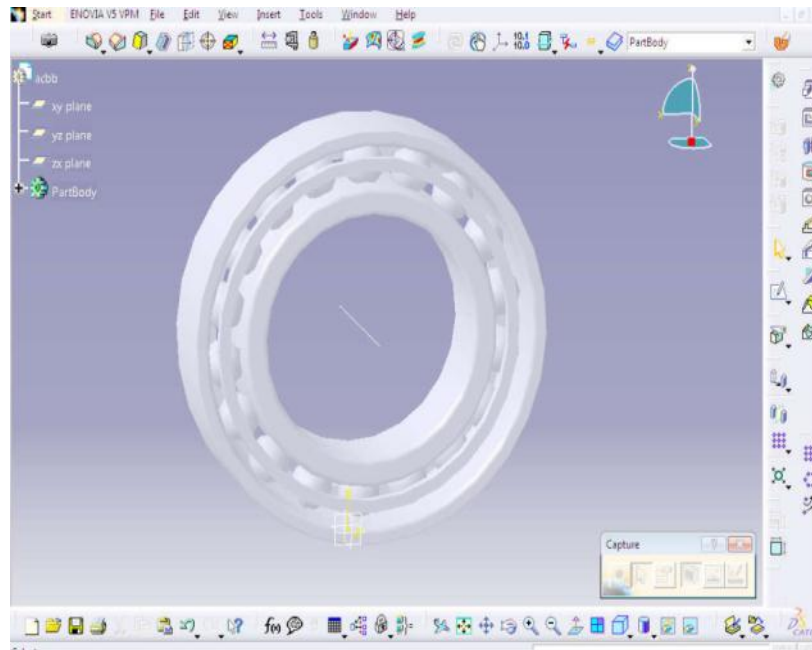

Figure No.1-Three dimensional model of 7008A ball bearing

5. MATERIAL PROPERTIES

The following are the material properties for different materials used in this project:

Table No. 3- Material Properties

PARAMETERS	Stainless Steel	Aluminum Oxide	Zirconium Oxide	Manganese Bronze
DENSITY (Kg/m ³)	7750	3000	5000	7700
ELASTIC MODULUS (GPa)	193	215	100	117
POISSON'S RATIO	0.31	0.21	0.22	0.34
TENSILE STRENGTH	465	69	115	820

6. DESIGN PARAMETER MATRIX

The following design parameter matrix is obtained using Taguchi's method of design of experiment in MINITAB software. Based on this design parameter matrix, nine three dimensional design models that contain different combinations of design parameters are prepared using standard dimensions with the help of CATIA V5 software.

Table No. 4- Design parameter matrix

S.No	MATERIAL	OUTER RACEWAY CURVATURE	NUMBER OF BALLS
1.	Stainless Steel	0.53d	12
2.	Stainless Steel	0.55d	15
3.	Stainless Steel	0.54d	18
4.	Aluminum oxide	0.53d	15
5.	Aluminum oxide	0.55d	18
6.	Aluminum oxide	0.54d	12

7.	Zirconium oxide	0.53d	18
8.	Zirconium oxide	0.55d	12
9.	Zirconium oxide	0.54d	15

7. STATIC STRUCTURAL ANALYSIS

7.1 Meshing

With the help of ANSYS 18 software, the elements of angular contact ball bearing in divided into a number of smaller parts which increases the accuracy of the analysis. The size of meshing element used is 10mm.

7.2 Boundary conditions

1. Outer ring is fixed
2. Radial load of magnitude 5000 N is applied in x-direction of inner race.
3. Axial load of magnitude 2500 N is applied in y-direction of inner race.

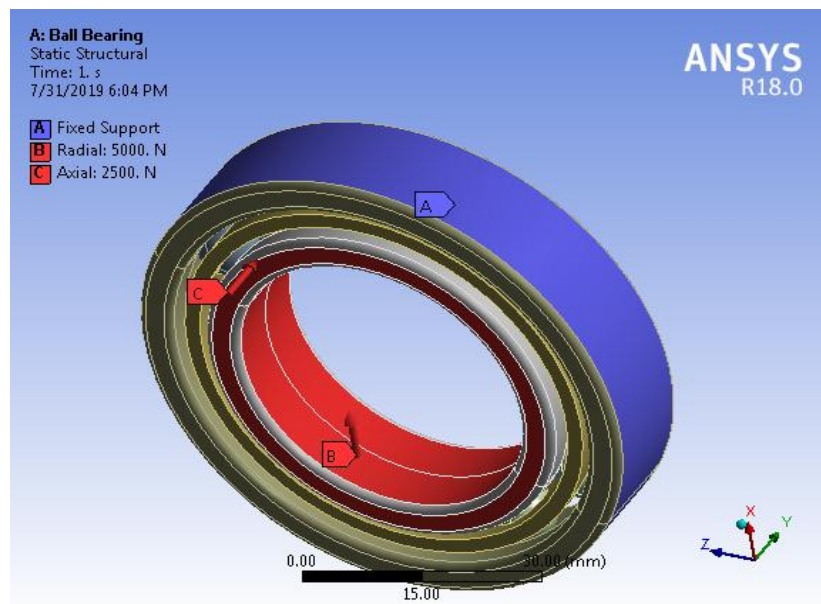
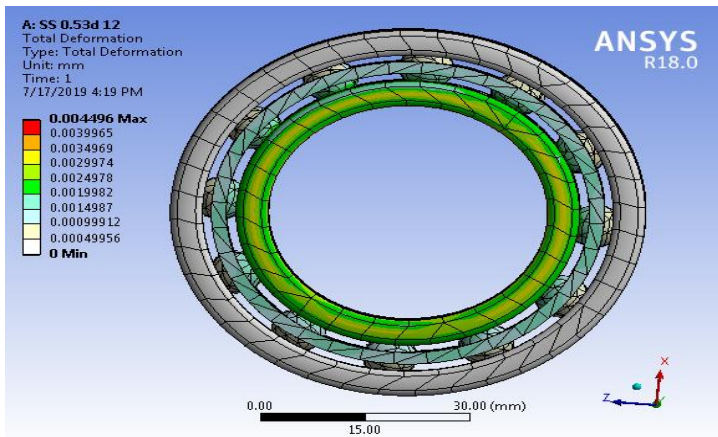

Figure No. 2- Boundary conditions for static structural analysis

7.3 Inputs and results

The static structural analysis is done for obtaining total deformation, equivalent stress (Von-Mises), fatigue life and fatigue damage by meshing and applying the boundary conditions. The following results are obtained.



(a) Total Deformation

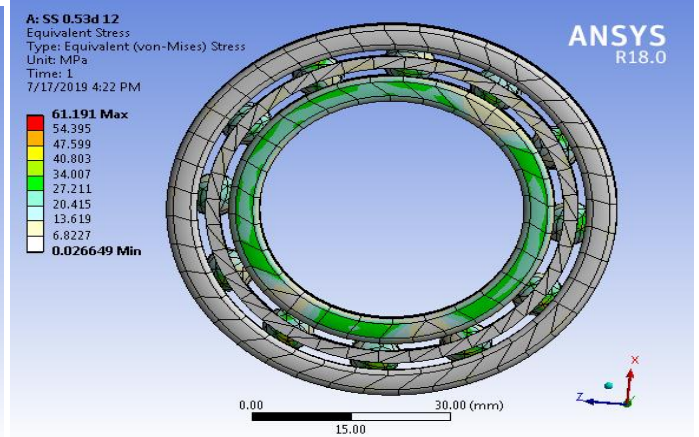

(b) Equivalent Stress

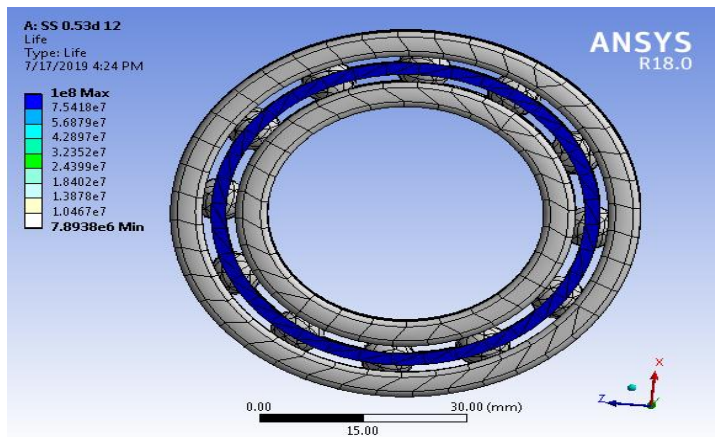

(c) Fatigue Life

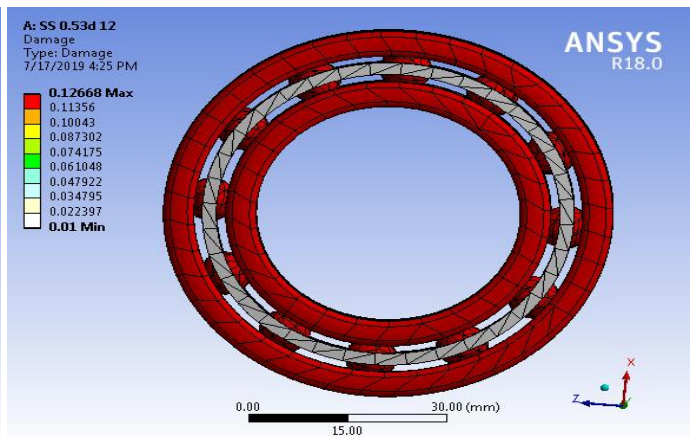

(d) Fatigue Damage

Figure no 3- Results for model SS 0.53d 12

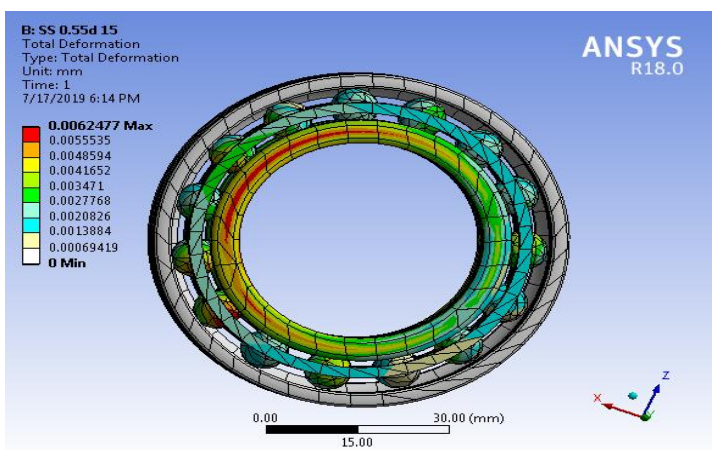

(a) Total Deformation

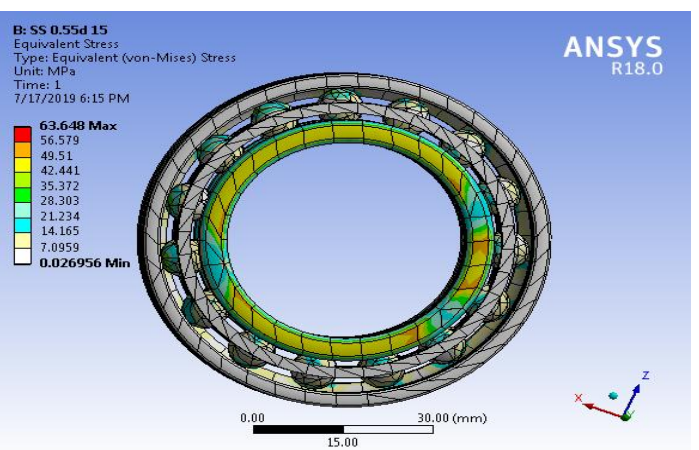

(b) Equivalent Stress

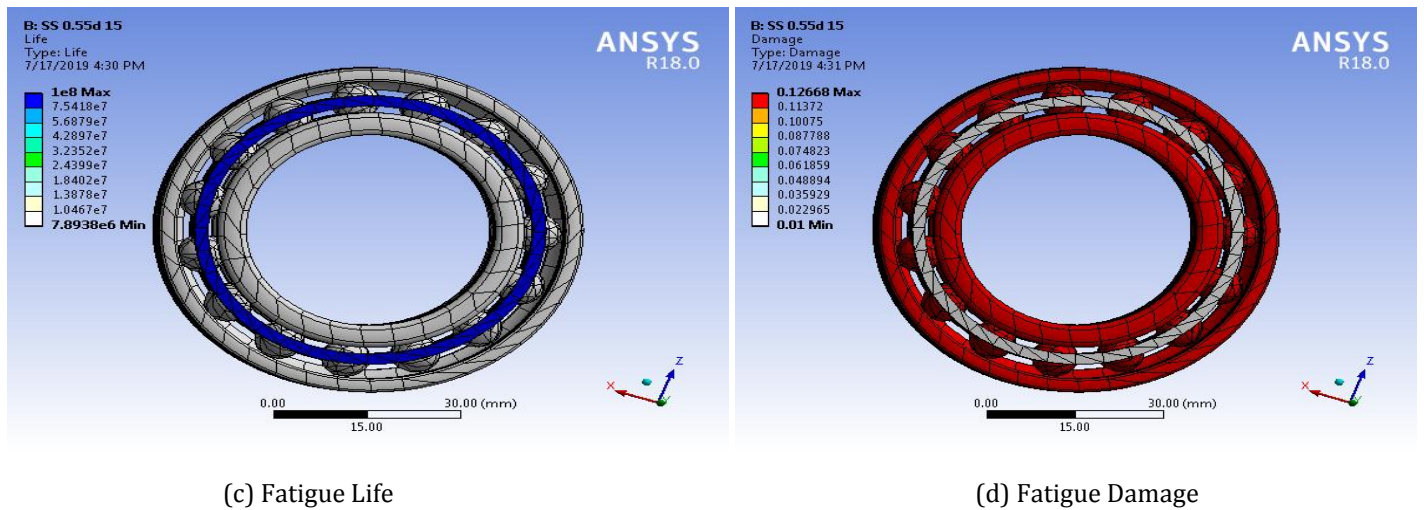

Figure no 4- Results for model SS 0.55d 15

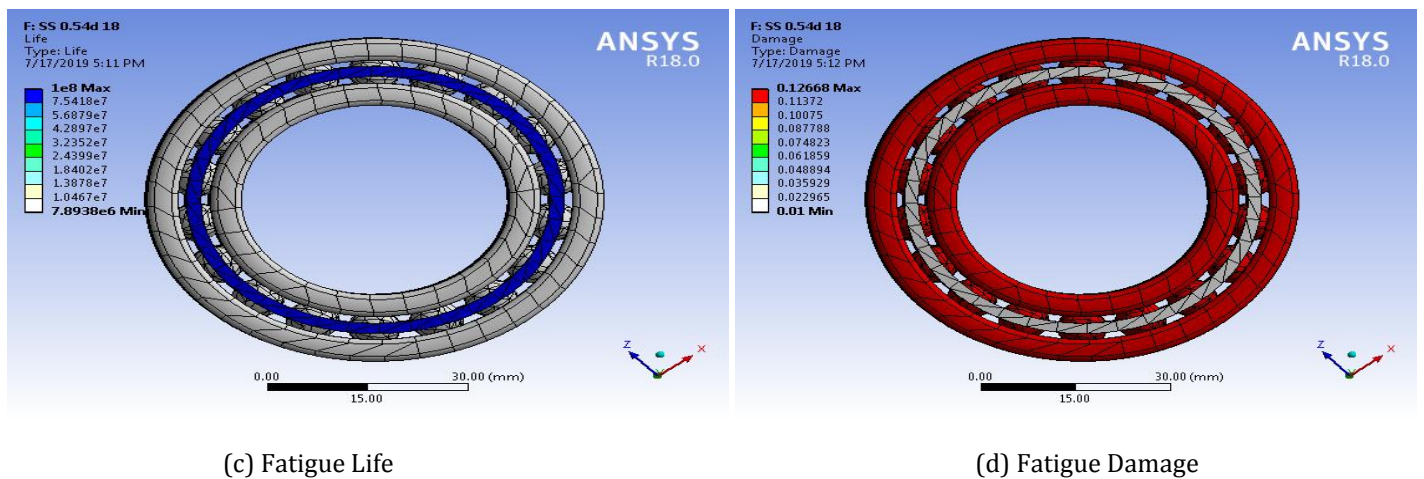
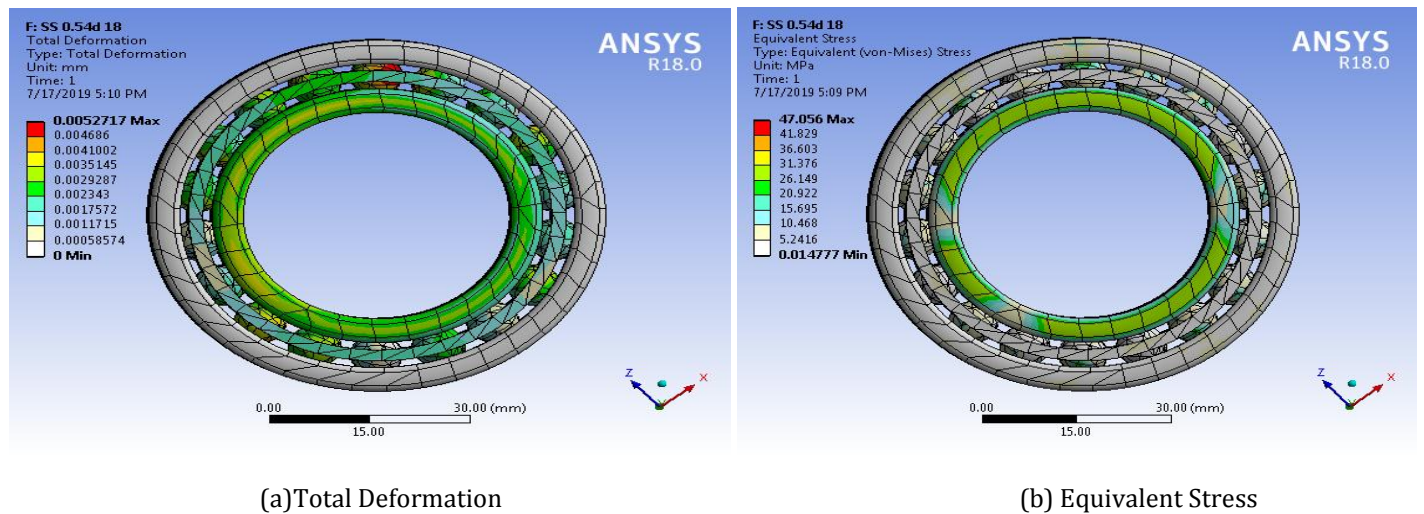
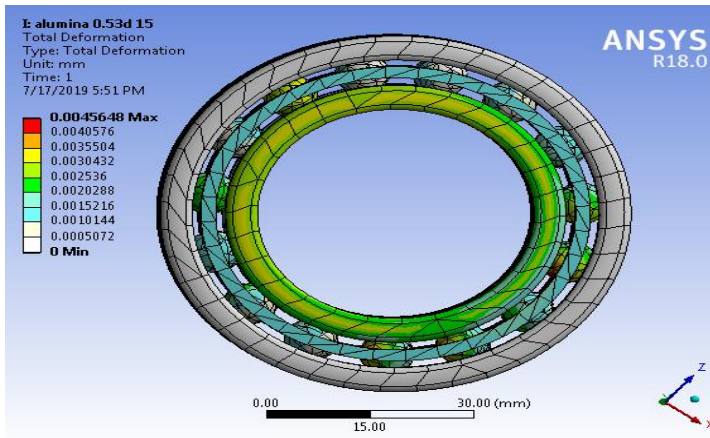
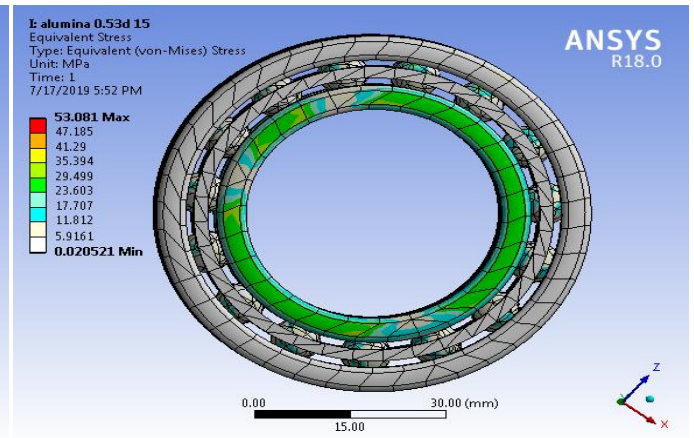

Figure no 5- Results for model SS 0.54d 18



(a) Total Deformation



(b) Equivalent Stress

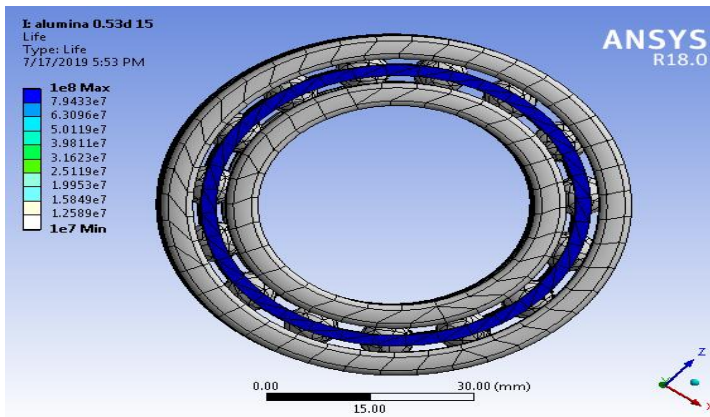

(c) Fatigue Life

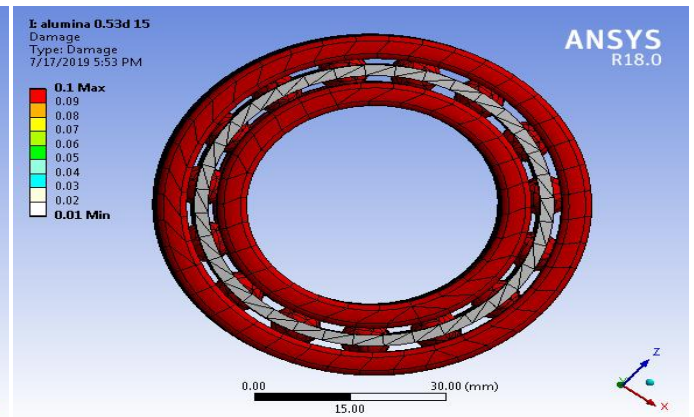

(d) Fatigue Damage

Figure no 6- Results for model Al₂O₃ 0.53d 15

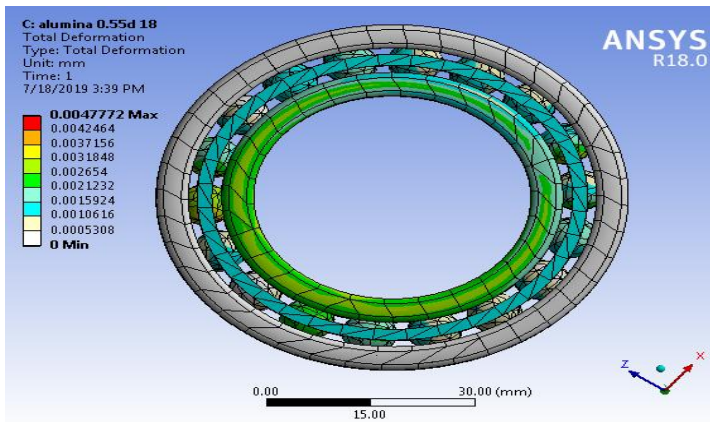

(a) Total Deformation

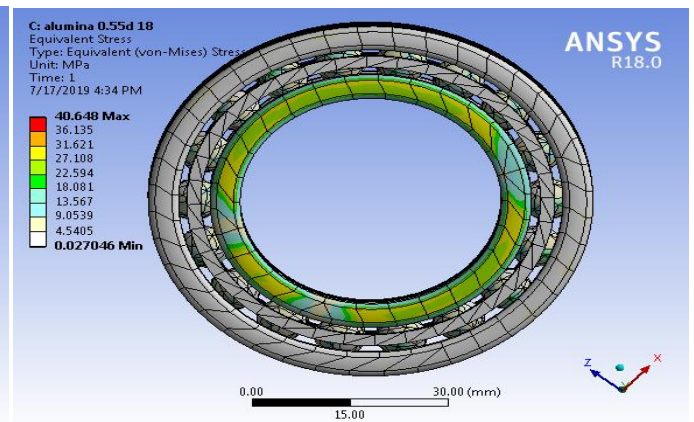

(b) Equivalent Stress

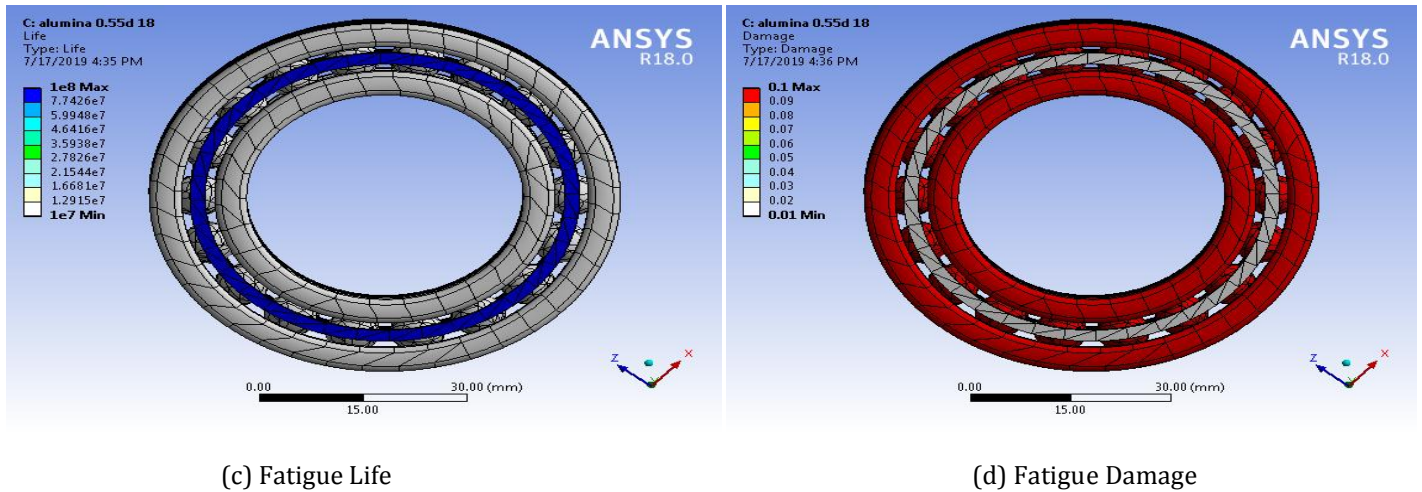

Figure no 7- Results for model Al₂O₃ 0.55d 18

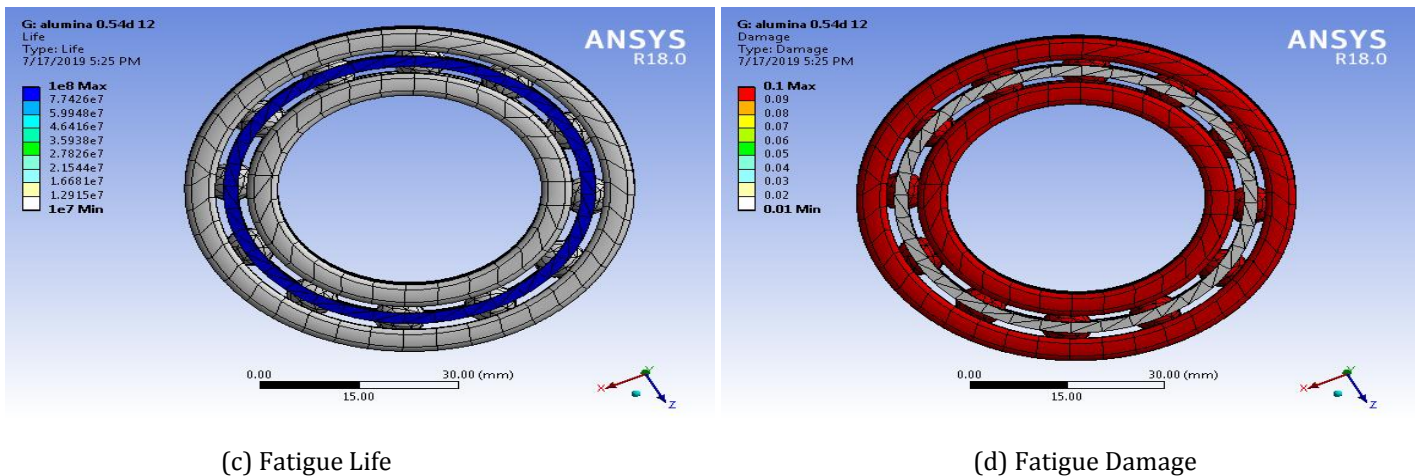
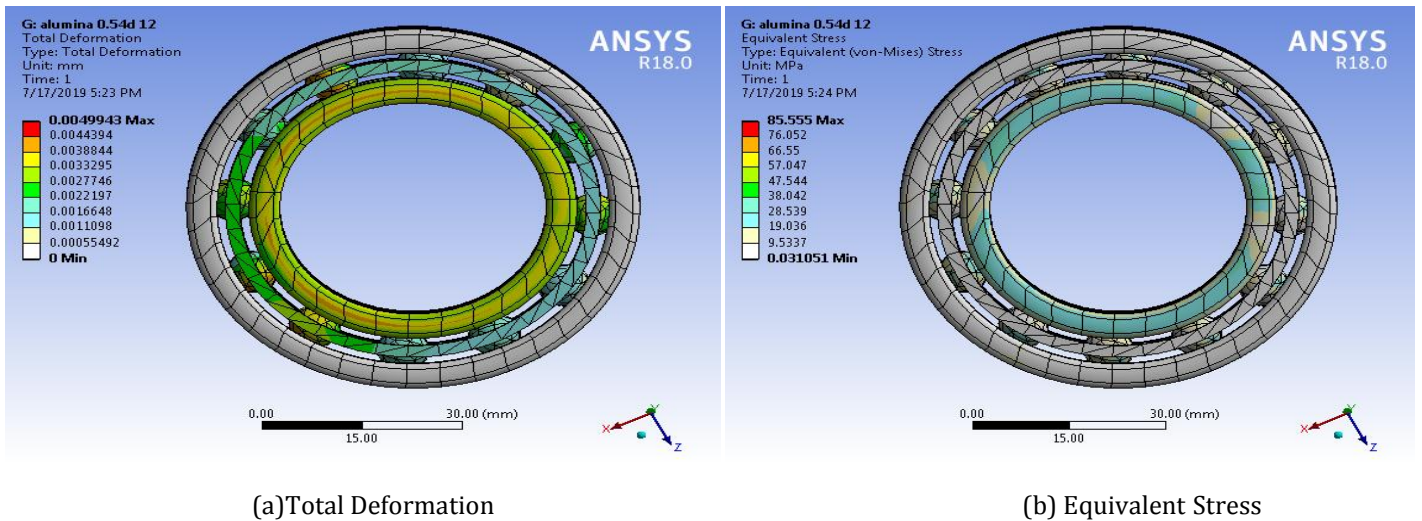
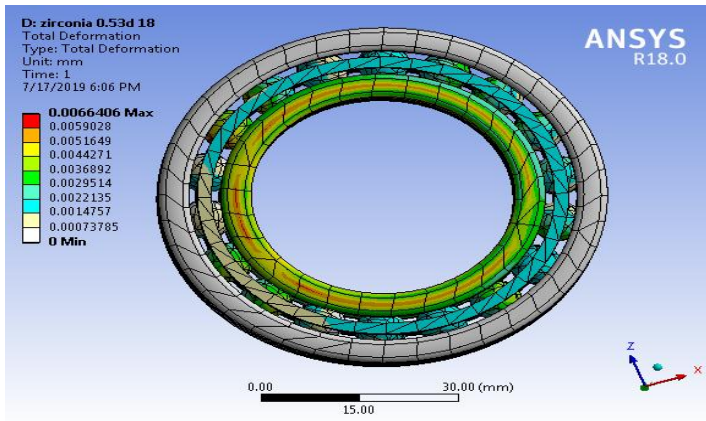
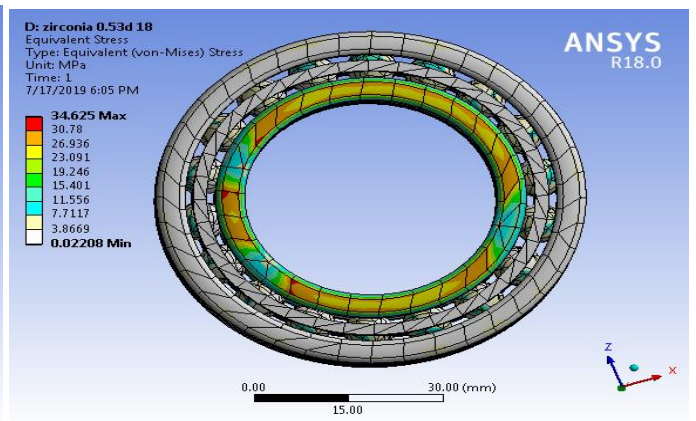

Figure no 8- Results for model Al₂O₃ 0.54d 12



(a) Total Deformation



(b) Equivalent Stress

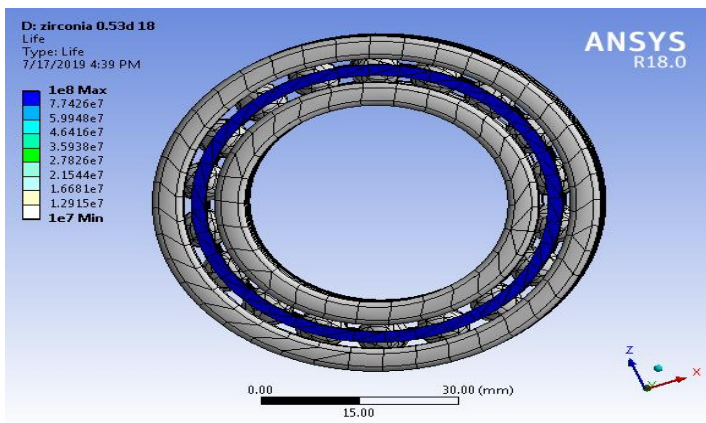

(c) Fatigue Life

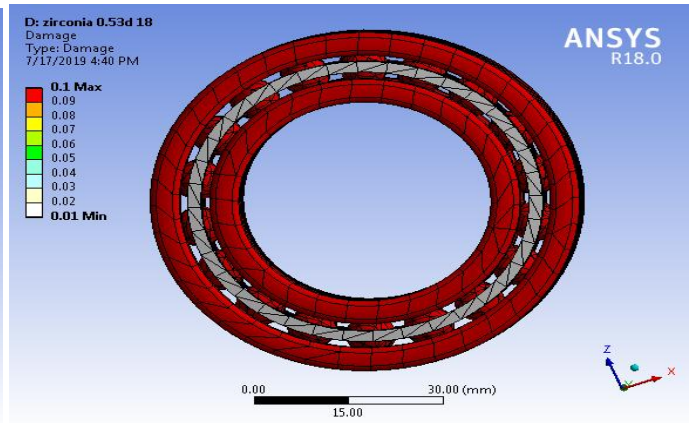

(d) Fatigue Damage

Figure no 9- Results for model ZrO_2 0.53d 18

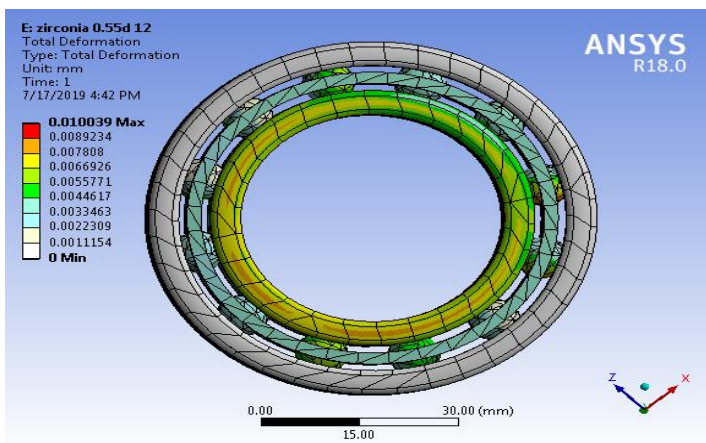

(a) Total Deformation

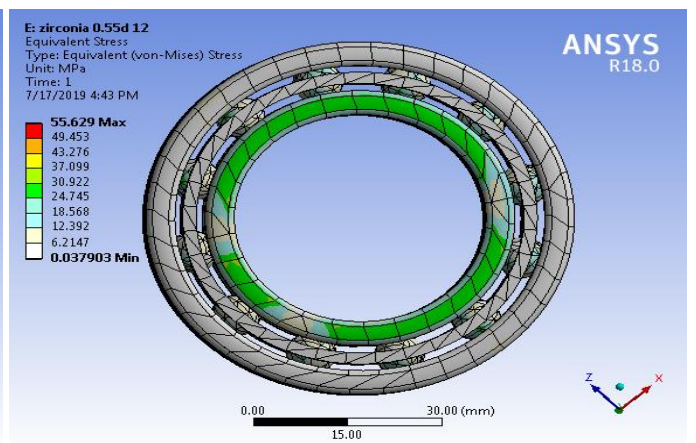

(b) Equivalent Stress

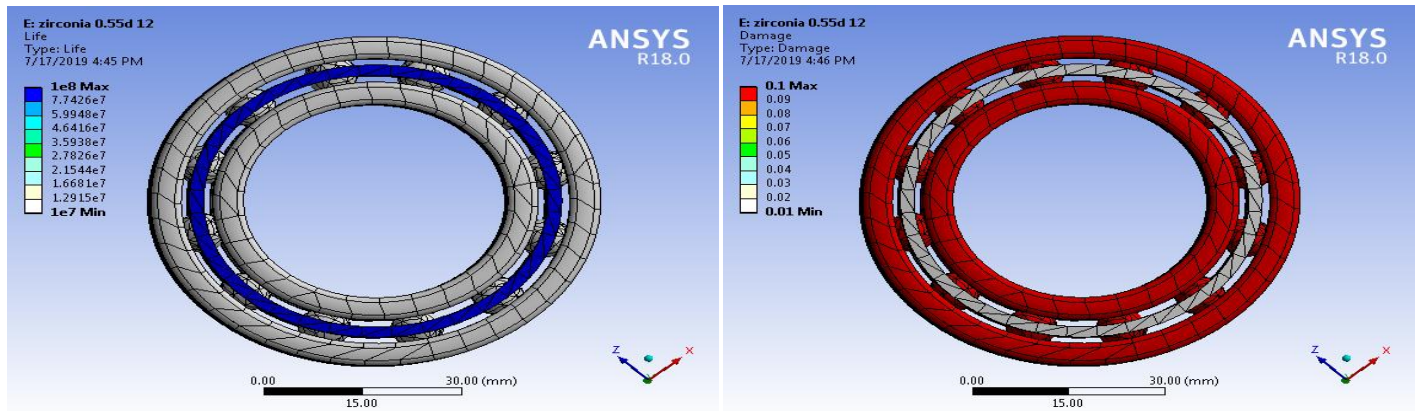

(c) Fatigue Life

(d) Fatigue Damage

Figure no 10- Results for model ZrO₂ 0.55d 12

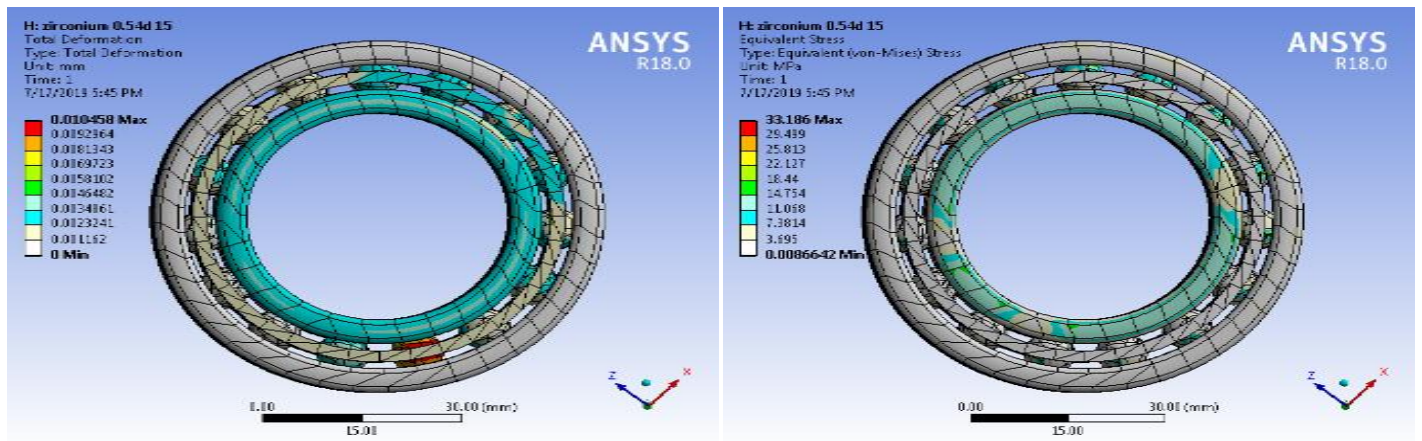

(a) Total Deformation

(b) Equivalent Stress

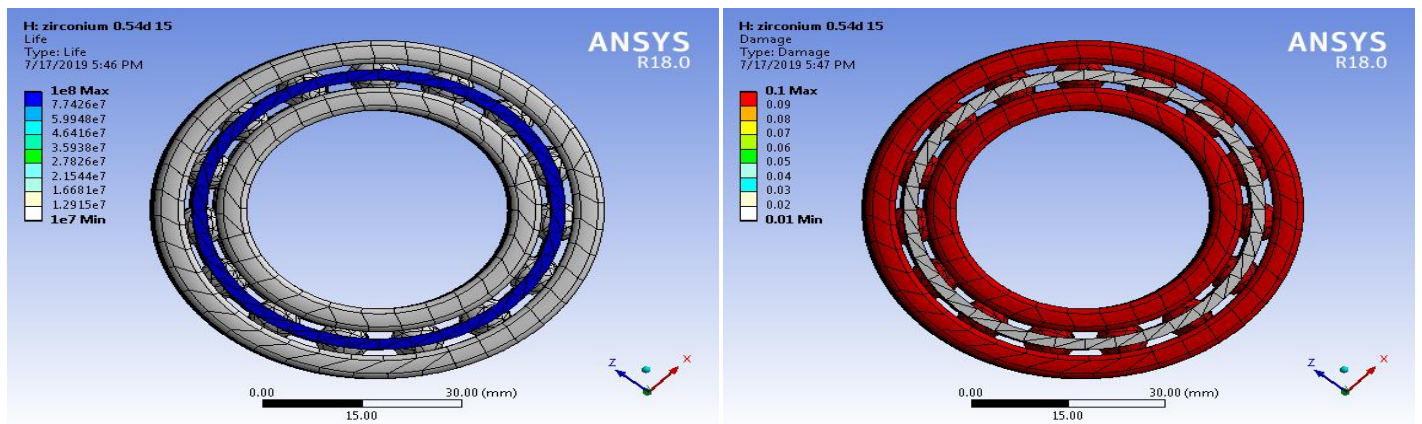

(c) Fatigue Life

(d) Fatigue Damage

Figure no 11- Results for model ZrO₂ 0.54d 15

Table No. 5- Theoretical and Static structural ANSYS results

S.No.	Model Name	Total Deformation(mm)		Equivalent Stress(MPa)		Fatigue Life	Fatigue Damage
		Actual	Theoretical	Actual	Theoretical		
1.	SS 0.53d 12	0.0044960	0.004220	61.191	53.04	7893600	0.12668
2.	SS 0.55d 15	0.0062477	0.004877	63.648	83.13	7893600	0.12668
3.	SS 0.54d 18	0.0052717	0.003827	47.056	62.96	7893600	0.12668
4.	Al ₂ O ₃ 0.53d 15	0.0045648	0.003516	53.081	50.93	10000000	0.10000
5.	Al ₂ O ₃ 0.55d 18	0.0062477	0.004172	63.648	81.04	10000000	0.10000
6.	Al ₂ O ₃ 0.54d 12	0.0051026	0.004994	85.555	74.57	10000000	0.10000
7.	ZrO ₂ 0.53d 18	0.0066406	0.005171	34.625	28.26	10000000	0.10000
8.	ZrO ₂ 0.55d 12	0.0100390	0.009081	55.629	55.87	10000000	0.10000
9.	ZrO ₂ 0.54d 15	0.0104580	0.007062	33.186	41.69	10000000	0.10000

8. TRANSIENT DYNAMIC ANALYSIS

Transient dynamic analysis is carried out with the help of ANSYS 18 software considering the rotational velocity of 1000 rpm, radial load of 5000 N and axial load of 2500 N, all being applied at the end of 2 second for the total time period of 3 seconds.

8.1 Meshing and boundary conditions

Meshing is done with the size of meshing element as 10 mm for increasing the accuracy of the analysis. The following boundary conditions are applied:

1. Outer ring is fixed.
2. Radial load of magnitude 5000 N is applied in x-direction of inner race.
3. Axial load of magnitude 2500 N is applied in y-direction of inner race.
4. Rotational velocity of magnitude 1000 rpm is applied on inner race, balls and retainer.

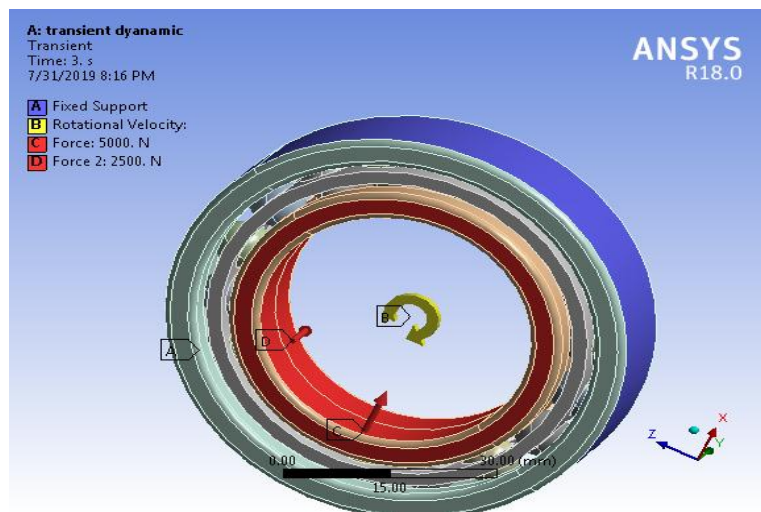
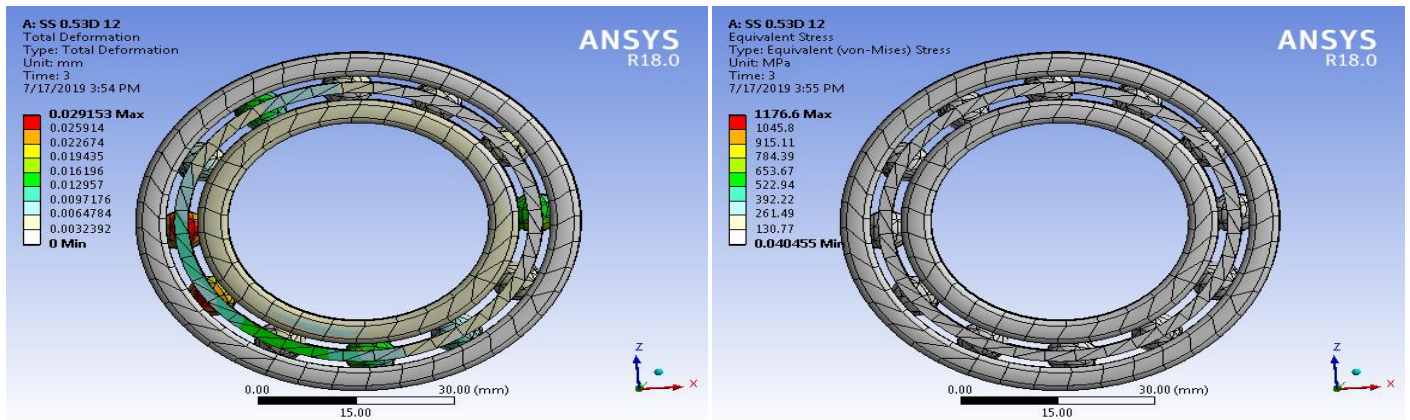

Figure no. 12- Boundary condition for transient dynamic analysis

8.2 Inputs and results

The transient dynamic analysis is carried out to obtain total deformation and equivalent stress(Von-Mises) of bearing under given boundary conditions. The following results are obtained.



(a) Total Deformation

(b) Equivalent Stress

Figure no 13- Results for model SS 0.53d 12

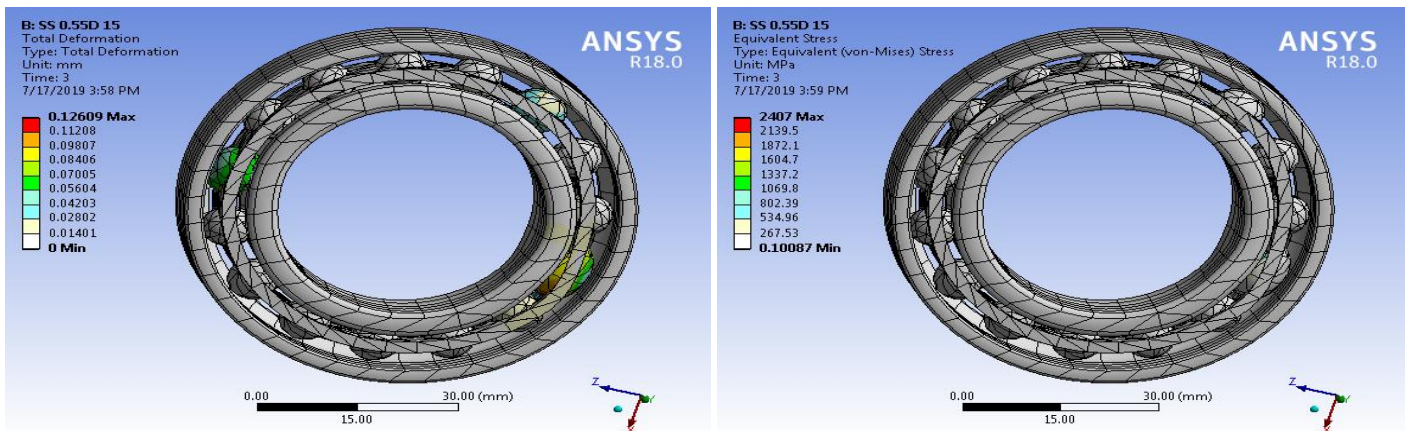

(a) Total Deformation

(b) Equivalent Stress

Figure no 14- Results for model SS 0.55d 15

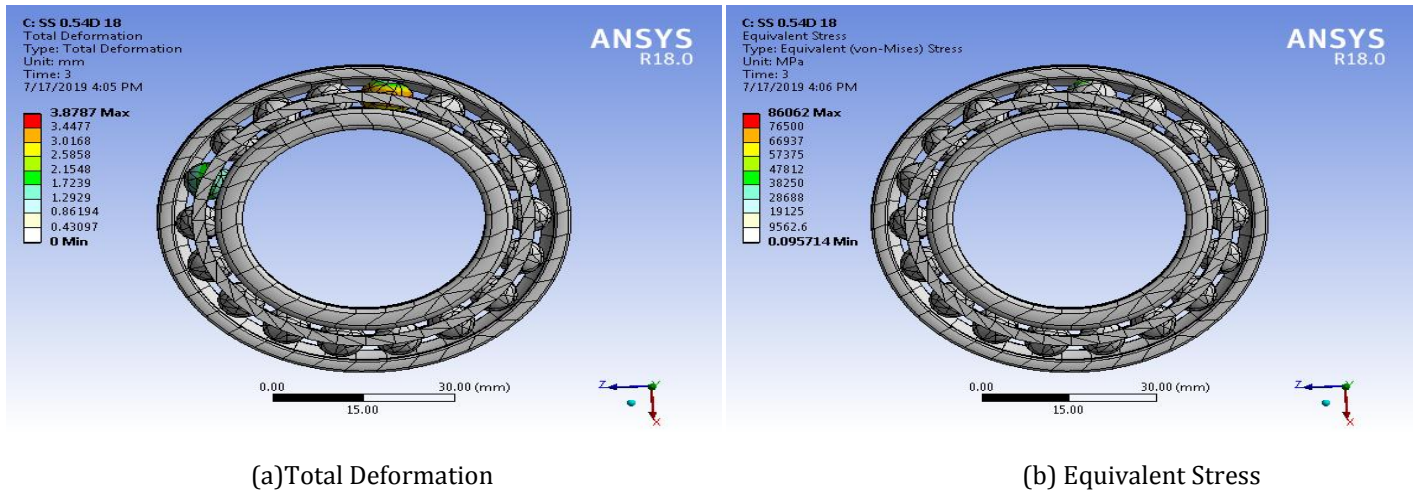

Figure no 15- Results for model SS 0.54d 18

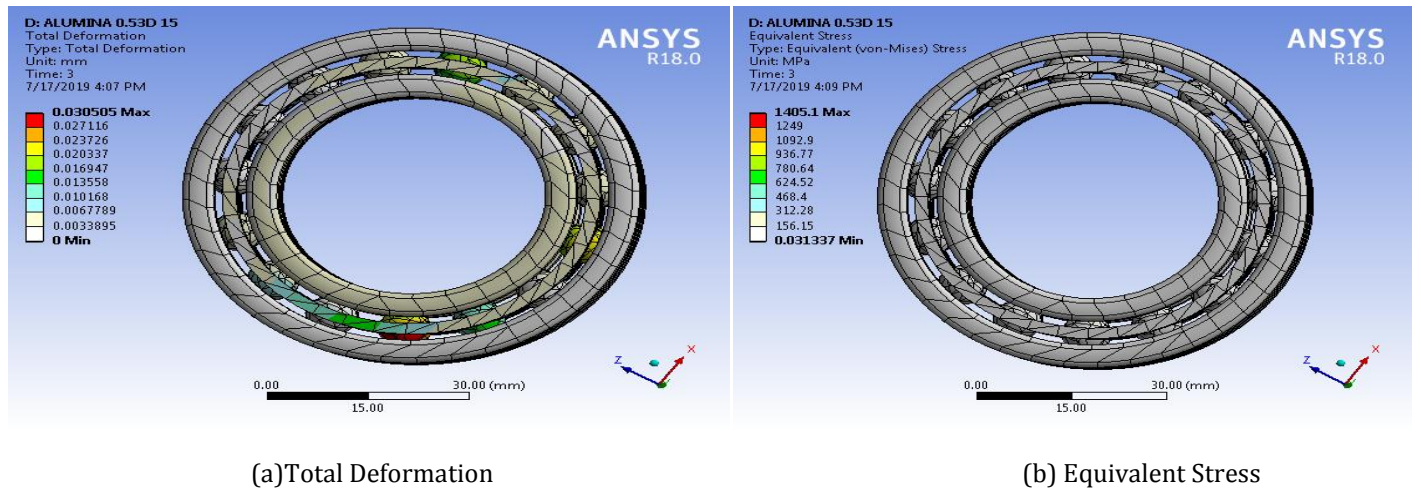

Figure no 16- Results for model Al₂O₃ 0.53d 15

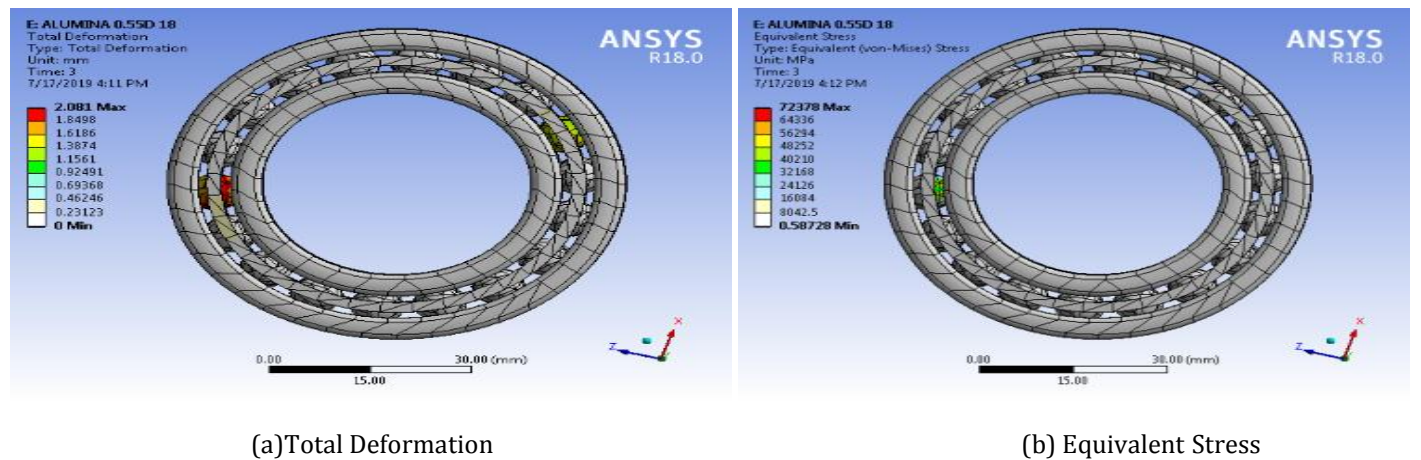
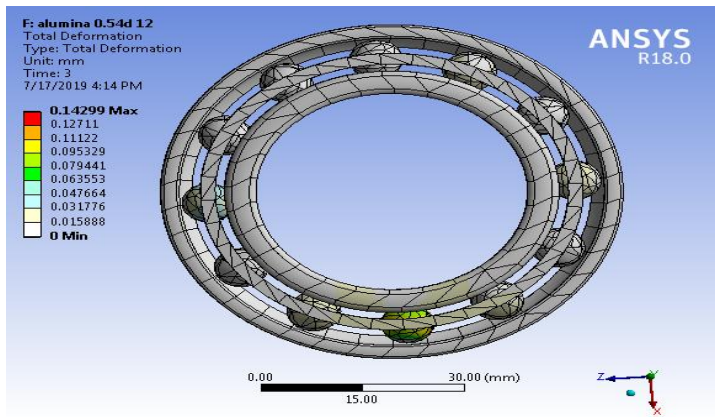
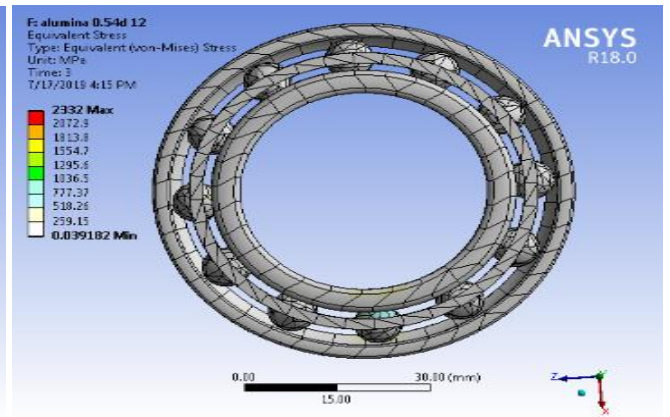

Figure no 17- Results for model Al₂O₃ 0.55d 18



(a) Total Deformation



(b) Equivalent Stress

Figure no 18- Results for model Al₂O₃ 0.54d 12

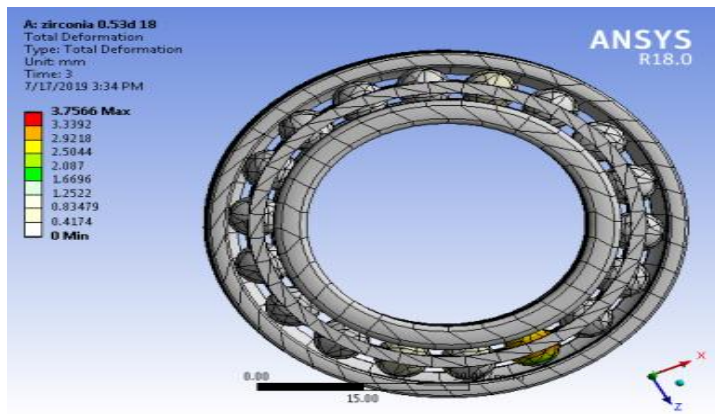

(a) Total Deformation

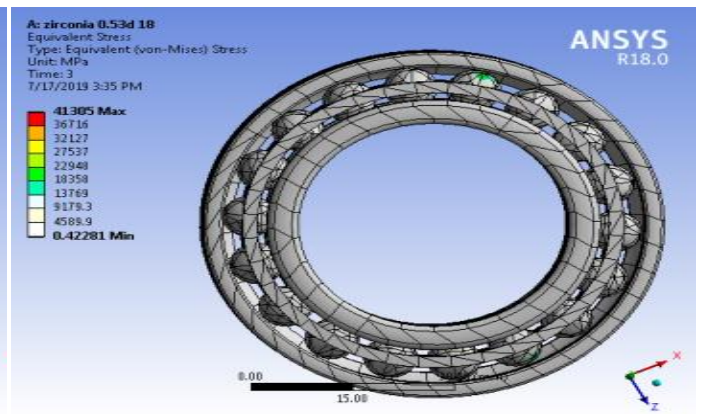

(b) Equivalent Stress

Figure no 19- Results for model ZrO₂ 0.53d 18

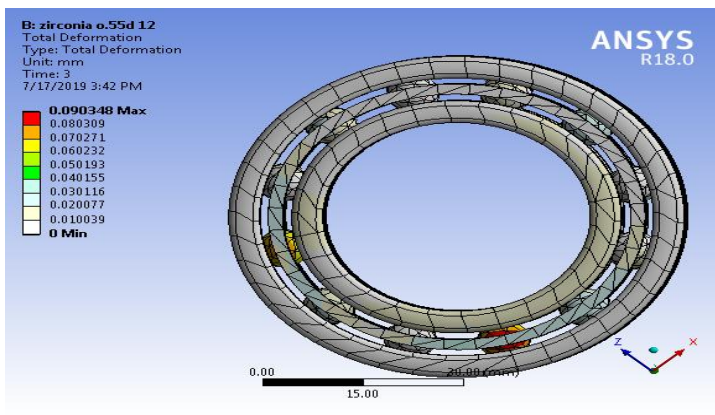

(a) Total Deformation

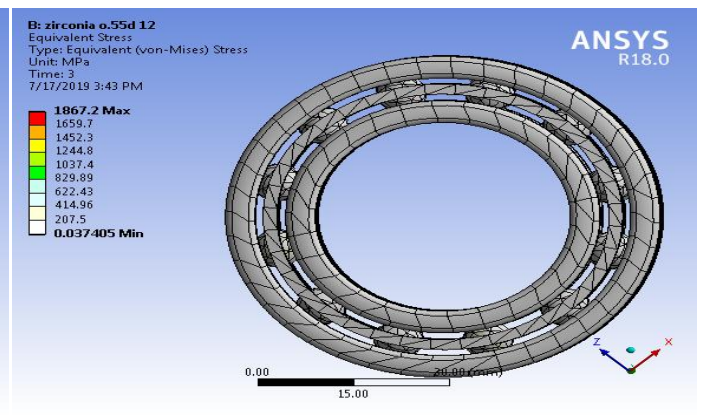

(b) Equivalent Stress

Figure no 20- Results for model ZrO₂ 0.55d 12

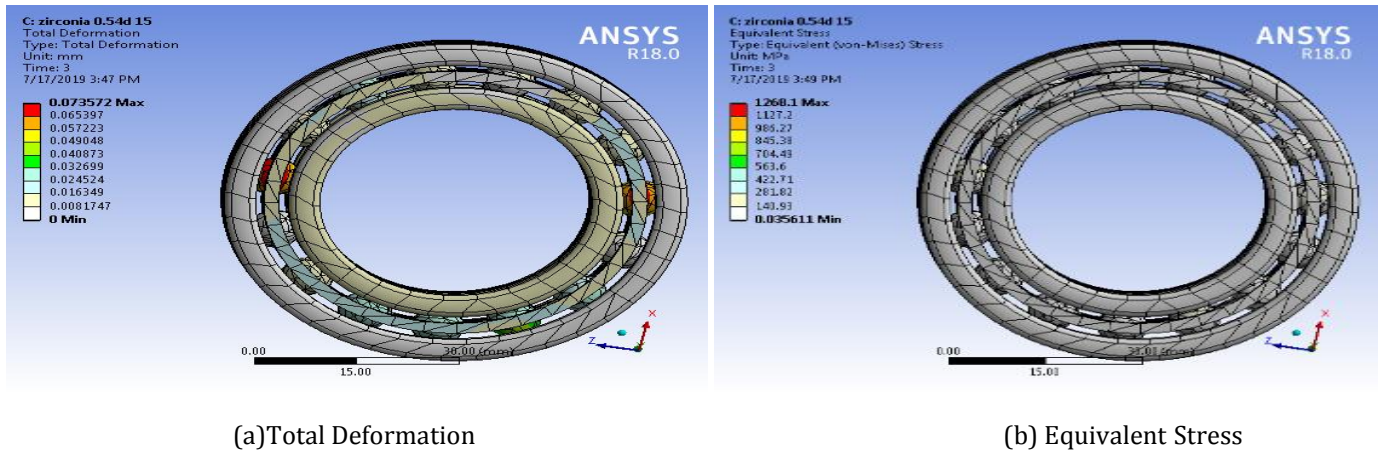

Figure no 21- Results for model ZrO₂ 0.54d 15

9. EFFECT OF DESIGN PARAMETERS

With the help of MINITAB software, response table and graph is obtained for total deformation, equivalent stress, fatigue life and fatigue damage using ANSYS results. Taguchi design is analyzed considering the response table such that smaller value for total deformation, equivalent stress and fatigue damage and larger value for fatigue life is considered to study the effect of design parameters on the performance of bearing. The graph is plotted for signal-to-noise ratio of results and the best design model is found out on the basis of these results. The S-N ration graph is basically the log function of the desired output that helps in optimization and data analysis of the results. The following results are obtained:

9.1 Discussion for static structural analysis results

Taguchi Design

Taguchi Orthogonal Array Design
L9(3**3)

Factors: 3

Runs: 9

Columns of L9(3**4) Array

1 2 3

Taguchi Analysis: TOTAL DEFORM versus MATERIAL, OUTER RACEWA, NUMBER OF BA

Response Table for Signal to Noise Ratios

Smaller is better

Level	MATERIAL	OUTER RACEWAY CURVATURE	NUMBER OF BALLS
1	45.53	45.77	44.25
2	45.58	42.71	43.50
3	41.04	43.67	44.40
Delta	4.54	3.06	0.90
Rank	1	2	3

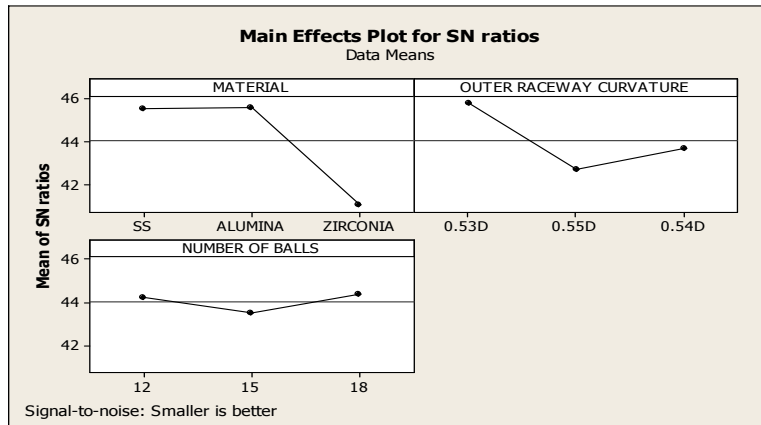

Figure No. 22- S-N Ratio graph for total deformation

Taguchi Analysis: EQUIVALENT S versus MATERIAL, OUTER RACEWA, NUMBER OF BA

Response Table for Signal to Noise Ratios
Smaller is better

Level	MATERIAL	OUTER RACEWAY CURVATURE	NUMBER OF BALLS
1	-35.09	-33.67	-36.43
2	-36.41	-35.69	-33.66
3	-32.04	-34.17	-33.44
Delta	4.37	2.01	2.99
Rank	1	3	2

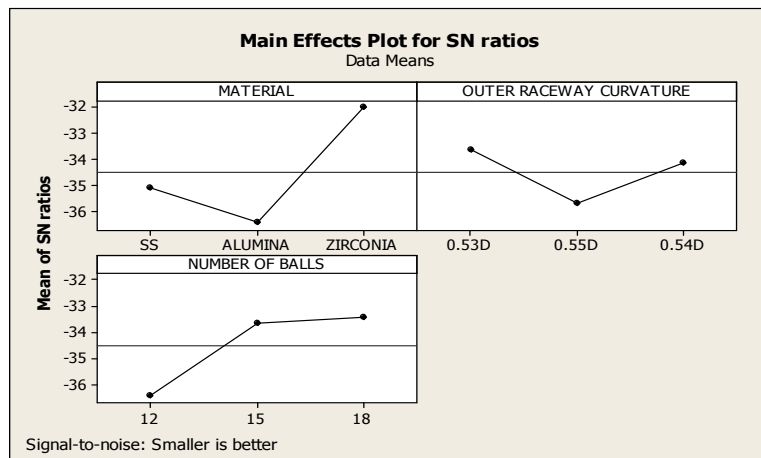

Figure No. 23-S-N Ratio graph for equivalent stress

Taguchi Analysis: LIFE versus MATERIAL, OUTER RACEWAY CU, NUMBER OF BALLS

Response Table for Signal to Noise Ratios
Larger is better

Level	MATERIAL	OUTER RACEWAY CURVATURE	NUMBER OF BALLS
1	137.9	139.3	139.3
2	140.0	139.3	139.3
3	140.0	139.3	139.3

Delta	2.1	0.0	0.0
Rank	1	2.5	2.5

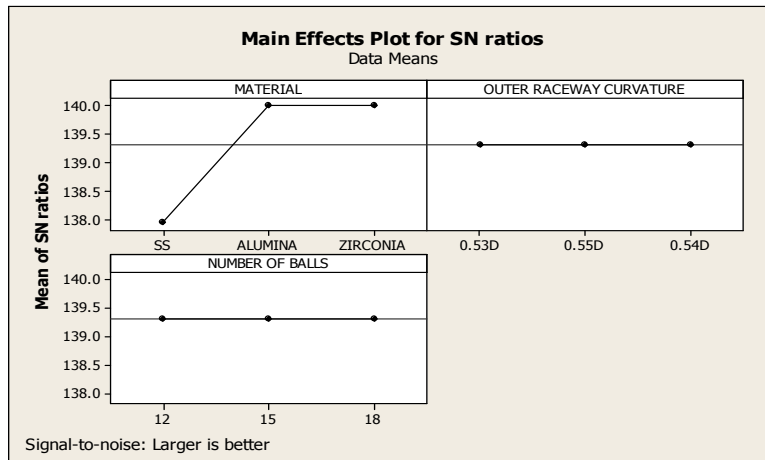

Figure No. 24- S-N Ratio graph for fatigue life

Taguchi Analysis: DAMAGE versus MATERIAL, OUTER RACEWAY CU, NUMBER OF BALLS

Response Table for Signal to Noise Ratios
Smaller is better

Level	MATERIAL	OUTER RACEWAY CURVATURE	NUMBER OF BALLS
1	17.95	19.32	19.32
2	20.00	19.32	19.32
3	20.00	19.32	19.32
Delta	2.05	0.00	0.00
Rank	1	2.5	2.5

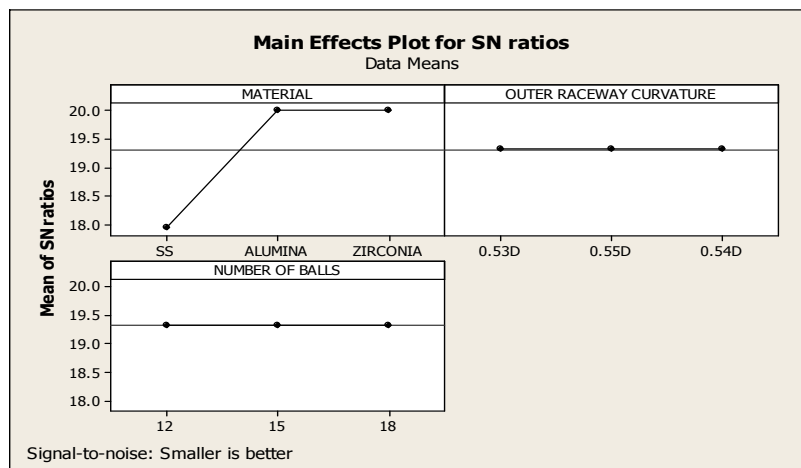

Figure No. 25-S-N Ratio graph for fatigue damage

Based on the S-N ratio response table and graph obtained from Taguchi’s design of experiment method, the following inference can be predicted for static structural analysis:

1. For least total deformation, ZrO₂ 0.55d 12 is better model than any other models used in this project.
2. SS 0.53d 12, Al₂O₃ 0.55d 15 and ZrO₂ 0.55d 12 are the models that give minimum value of equivalent stress.
3. All models having Al₂O₃ and ZrO₂ as a material gives maximum fatigue life and minimum fatigue damage.

9.2 Discussion for transient dynamic analysis results

Taguchi Design

Taguchi Orthogonal Array Design
L9(3**3)

Factors: 3
Runs: 9
Columns of L9(3**4) Array
1 2 3

Taguchi Analysis: TOTAL DEFORM versus MATERIAL, OUTER RACEWA, NO.OF BALLS

Response Table for Signal to Noise Ratios
Smaller is better

Level	MATERIAL	OUTER RACEWAY CURVATURE	NO.OF BALLS
1	12.306	16.508	22.827
2	13.614	10.834	23.655
3	10.684	9.262	-9.878
Delta	2.930	7.246	33.533
Rank	3	2	1

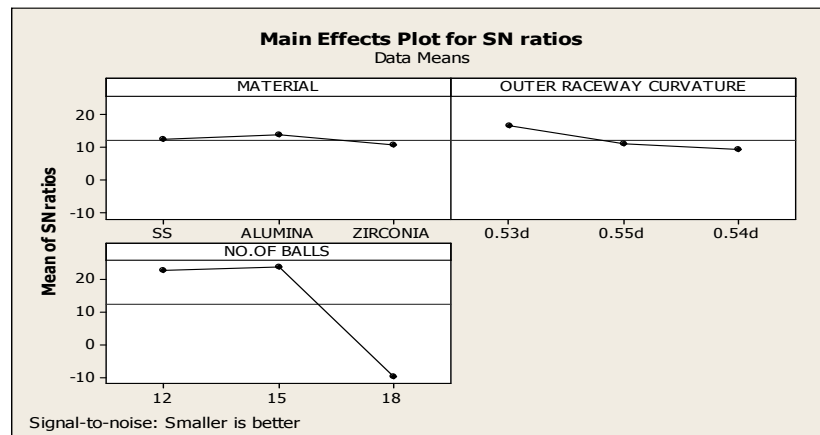

Figure No. 26-S-N Ratio graph for total deformation

Taguchi Analysis: EQUIVALENT S versus MATERIAL, OUTER RACEWA, NO.OF BALLS

Response Table for Signal to Noise Ratios
Smaller is better

Level	MATERIAL	OUTER RACEWAY CURVATURE	NO.OF BALLS
1	-75.91	-72.23	-64.73
2	-75.83	-76.75	-64.22
3	-73.27	-76.04	-96.07
Delta	2.64	4.52	31.85
Rank	3	2	1

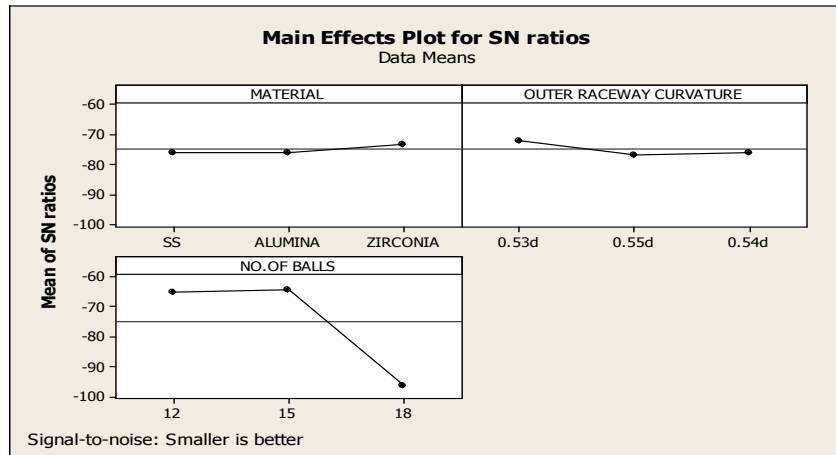

Figure No. 27-S-N Ratio graph for equivalent stress

Based on the S-N ratio response table and graph obtained from Taguchi’s design of experiment method, the following inference can be predicted for transient dynamic analysis:

1. For least total deformation, SS 0.54d 18 is better model than any other models used in this project.
2. Al₂O₃ 0.55d 18 and SS 0.54d 18 are the models which gives minimum value of equivalent stress.

10. CONCLUSIONS

The theoretical and ANSYS results are compared and it is found that outcomes of both results are approximately the same. Under given boundary conditions, the effect of design parameters can be studied using Taguchi’s design of experiment method. It is, therefore, concluded that the best model which gives minimum total deformation, equivalent stress and fatigue damage, and maximizes the fatigue life is as follows:

Table No. 6-Best design models

Analysis Type	Material	Outer raceway curvature	Number of balls
Static Structural	Zirconium oxide	0.55d	12
Transient Dynamic	Stainless Steel	0.54d	18

10. REFERENCES

[1]Fengtao Wang, Minquig Jing, Hongwei Fan, Yaobing Wei, Yang Zhao and Heng Liu, "Investigation on contact angle of ball bearings", Institution of Mechanical Engineers, Vol. 231(1) 230-251,2016.

[2]Anoopnath P.R., V. Suresh Babu, Vishwanath A.K., "Hertz contact stress of deep groove ball bearing", ELSEVIER, Proceedings 5 3283-3288, 2016.

[3]Wei Guo, Hongrui Cao, Zhengjia He and Laihao Yang, "Fatigue life analysis of rolling bearings based on quasistatic modeling", Hindawi Publishing Corporation, Article ID 982350, Volume 2015.

[4]Baomin Wang, Chao Gao, Bing Du, Wu Zaixin, "The effect of materials on fatigue life of angular contact ball bearing", International Journal of Stimulation System, Science & Technology, Volume 2017.

[5]Shubham B.Kadam, Prof. P.G. Patil, Prof. R.Y. Patil, "Contact stress analysis & material optimization of ball bearing using Hertz contact theory", Volume 5, Issue 1, International Research Journal of Engineering and Technology, IISN: 2395-0072, 2018.

[6]S.R. Dutta, S.K. Singh, R. Ranjan, "Analysis of angular contact ball bearing design", International Journal of Science and Research, IISN: 2319-7064, Volume 3, Issue 8, 2014.

[7]Prabhat Singh, Prof. Upendra Kumar Joshi, "Fatigue life analysis of thrust ball bearing using ANSYS", International Journal of Engineering Sciences & Research Technology, ISSN: 2277-9655, 2014.

[8]Darshan Adeshara, Dr.Pranav Darji, "A review of design and analysis of angular contact ball bearing for two wheeler clutch", International Journal of Advanced Engineering and Research Development, Volume 2, Issue 5, 2015.

[9]Putti Srinivasa Rao, Narise Saralika, "Static structural and transient dynamic analysis of 6200 deep groove ball bearing", SSRG International Journal of Mechanical Engineering, IISN: 2348-8360, 2017.

[10] Howard E. Boyer, "Atlas of Fatigue Curves", American Society for Metals, 1986.

[11] Michael M. Khonsari, E. Richard Booser, "Applied Tribology", third edition, Wiley Publication.

[12] Bharat Bhushan, "Introduction to Tribology", second edition, Wiley Publication.