

IoT based Intelligent Car System for Preventing Suffocation in Closed Car Cabin using Sensors

Shrishti Manoj Pekhale¹, Pranita Dattatray Shirsat², Pooja Pravin Jadhav³, Kishor N. Shedge⁴,
Sweety G. Jachak⁵

¹Information Technology Engineering

^{2,3}Computer Engineering

⁴HOD of Comp. Department (Internal guide)

⁵Assistant Professor of IT Department (Internal guide), SVIT, Nasik, Maharashtra, India

Abstract - As the smart system has been developed in the automobile industries, new features are implemented for the comfort of customer. However, if a car is locked, creating a closed cabin, the unmindful toddlers and animals (pets), in the car, cannot open the door or windows. The closed car cabin may result in depletion of oxygen (O_2). Concentrating on the problems occurred due to suffocation in car, it reveals that in the closed cabin the oxygen level decreases with a constant speed as the living being inhales the oxygen (O_2) and exhales carbon dioxide (CO_2), which results in the scarcity of oxygen (O_2). Hence, this proposed work deals with the safety of loved ones sitting in the closed car cabin, which connects PIR motion sensor, carbon dioxide (CO_2) sensor, micro-controller, timer, GSM modem, air blower, car buzzer and power windows. The micro-controller will make the decision regarding opening the power windows, turning the buzzer or air blower on and sending electronic alert message through GSM modem. This system will help the toddlers or pets to get out of the car. In critical situations like if the carbon dioxide (CO_2) level increases to 0.2% (2000ppm) then an alert message will be send to the nearby hospital, automobile service station or police station and will turn on the car buzzer to inform nearby people.

Key Words: PIR motion sensor, Carbon dioxide (CO_2) sensor, Global Positioning System (GSM), Global Mobile System (GSM) and Micro-controller

1. INTRODUCTION

Many developments are made in automobile industries regarding the comfort of people. However, not all obstacles are overcome. This study focuses on one problem that is suffocation in the closed car cabin, due to dearth of oxygen. The victims of this major problem are, mainly, toddlers, pets, and physically disabled persons because they are not aware of the unlocking system of a car. The living being inhales oxygen (O_2) and exhales carbon dioxide (CO_2). The level of carbon dioxide (CO_2) increases in the closed car cabin which results in the suffocation of the loved ones. The air contains 78.09% nitrogen, 20.95% oxygen, 0.93% argon, 0.04% carbon dioxide, and remaining amount of other gases. The research shows that a living being requires 21% of oxygen (O_2) and 0.04% (400 ppm) of carbon dioxide (CO_2) in

air for normal respiration under normal temperature and pressure. The chances of occurrence of death starts with the carbon dioxide reached to 4% (40,000 ppm) or above it in the air (or in closed ca/room) [16]. In between 0.04% to 0.2%, two levels of carbon dioxide (CO_2) are considered in this study. The levels measure 0.1% and 0.2%. As the level of carbon dioxide (CO_2) increase from 0.04% to 0.1%, the respiratory rate of a living body increases by 37% but it is relatively safe for the person who acclimates to it. The proposed theory uses a carbon dioxide sensor that detects the level of carbon dioxide (CO_2) in the closed cabin. The increase in carbon dioxide (CO_2) level in cabin is harmful for the person. If the level of CO_2 reaches 1% to 2%, then the breathing rate becomes deeper (50% than normal). When the CO_2 level strikes 3% in air, the person may feel headaches and there will be increase in blood pressure and pulse rate.

There are many methods for anti-suffocation in vehicles. The research paper, Smart and Efficient Personal Car Assistant System, explains the solution for car related problems which are faced by car owner and users in day-to-day life like remembering the renewal date of PUC, suffocation due to overheating, routine check-ups and maintenance. This system can be used to provide the necessary support to manage the entire car related thing by using android application. An android application is developed to provide the features like reminder for PUC, alert the car user, etc. Thus, this system is proposed to develop an android application which provides features for car [1]. The next research paper, Vehicle and Passenger Protection through Cooperative Sensor Based Vehicular Networking, has an objective to provide the protection for passengers, who are inside the car, through sensor, to avoid suffocation. Due to no ventilation, as AC is used in modern cars, it makes car environment suffocating while the car is locked creating a closed cabin, which may cause death when someone is trapped inside the car for long duration. By using an android application, the system can send alert message to car owner. If no action is specified after getting alert message then it sends alert message to nearby hospital and police by using GSM and GPS. The main purpose of this system is to provide protection for passengers [2]. Chanda Nikhil Kumar et al. (2018) studied E.A.S.T which is an IOT based

temperature system for the safety of loved ones in which it takes the values of the temperature and humidity from temperature sensor, uploads to the cloud and alerts the people around the car to save the child or pet in the locked car [3]. A. Rajendra Prasad et al. (2017), here gas sensors are used to sense the level of CO₂, the sensor gives the signal to Arduino UNO chip. Arduino sends signal to the DC motor of the power window. The entire setup is run by a 12V battery. Once the DC motor receives the signal from Arduino, it runs and pulls the window down [4]. Sangita N. Gujar et al proposed a system that works on the sensors, GPS, GSM system to avoid accidents and Wrong tracks [5].

The proposed system explains the use of carbon dioxide (CO₂) monitoring sensor, water sensor and smoke sensor in rescuing the living being from the closed car cabin. This methodology also deals with the Global Positioning System (GPS) and Global Services for Mobile Application (GSM) interfacing with PIC micro-controller and its series. The water sensor is used to detect the water reaching to the engine, which will result in locking of the car in the position as it is. This will eventually create a closed cabin and will lead to increase in carbon dioxide (CO₂).

Therefore, to avoid this, the water sensor will sensor the water and will, immediately, open the windows and will unlock the doors of the car. The smoke sensor is used to detect the smoke in car. Now a day, the youth is being addicted to cigarette smoking in car with the windows close. This may result in setting the car on fire; hence the smoke sensor will sense the smoke and according will open the windows of car.

1.1 Problem Statement

Unawareness of unlocking system of car and the increase in carbon dioxide level in the closed car cabin leads to the suffocation of pets or toddlers or loved ones. The incident of freezing ice-creams kept in the closed car with a kid sleeping in car showed that the sudden rise in CO₂ level resulted in the suffocation of child. The freeze ice-creams are nothing but freeze CO₂ that started releasing in the air. Therefore, the increased level of CO₂ in the car led to the death of child. No rescue measures were taken by the time to save him, and this fatal accident occurred. The related news like this, are explain in the next section.

To overcome situations like this, a system is proposed to rescue the human being using the technology IOT (GPS and GSM) with minimal power consumption to operate power car windows while the car is locked.

1.2 Related News

- Two Children Get Trapped In Car, Die Of Suffocation In Buldhana , Maharashtra [11]

Date: 16 July 2019

- Shocking News is Husky locked in car for TWO HOURS in suffocating 82F heat before police break in to set it free - as 'idiot' owners arrive and ask: 'What's the problem?' [12]

Date: 18 July 2018



- Kid 'Forgotten' In Locked Car, Dies In Bhopal Mar 26, 2018 [13]



- The death of Mr. Priyam Mainthia, due to suffocation in locked car, parked in flood, reminds of 267 deluge of 2005 in which an entire family in Juhu had died of suffocation inside their vehicle on a waterlogged street after the doors failed to open due to power failure [14]



STAYING PUT IN A SUBMERGED CAR CAN BE FATAL

DRIVING IN FLOODED AREAS

- Always drive in first gear. Use a lot of revs and drive steadily.
- Avoid speeding, drive at slow and steady pace.
- If water is higher than wheels, best to avoid the road.
- Assess depth of water by watching other cars going through.
- Set out only if water is half a foot lower than air inlet to avoid water from entering engine.
- If you suspect water has entered engine, immediately switch off car to avoid further damage.

IN CASE YOU GET STUCK INSIDE CAR ON FLOODED ROAD

- Sometimes car windows pop due to dead battery and locking system may fail but you will still be able to manually override the locks.
- Keep track of oxygen levels in car. Submergence may block air vents. If it gets claustrophobic, don't hesitate to abandon car and get to safety.
- Open passenger door with both feet and get out. If force of water is too strong to kick open the door, use detachable headrest in car to smash window open.
- Do not try to break open windows. Reinforced glass is extremely strong.

16 lives snuffed out inside cars

Priyam Mainthia's body was found lying inside his vehicle near Gandhi Market in Kirti Circle.

IRJET report on July 26, 2019, days after the deluge

2. OBJECTIVE

- The system first deals with a PIR sensor to detect if there is any person in the locked car.
- If there is, carbon dioxide (CO₂) sensor, water sensor, and smoke sensor are activated which will detect the level of carbon dioxide, water and smoke, respectively, in closed car cabin.
- When the level of CO₂ is detected above 0.04%, or water or smoke is detected then an alert message is sent with the help of GSM and GPS.

- Waiting for a period, the micro-controller will take the power windows down or will turn the air blower on for fresh air supply.

3. PROPOSED METHODOLOGY

3.1 Proposed Blocked Diagram:

In the below block diagram, the connection of gathered components is shown. The interfacing of micro-controller with sensors used, GSM module, and GPS are explained (will be studied next). The block diagram represents the communication between the PIR motion sensor, water sensor, smoke sensor, and CO₂ sensor. The data is transferred from these sensors and GPS (information of location) to the micro-controller. After processing the input data and concluding the desired decision, the micro-controller passes signal back to sensor, GSM module and necessary actions are taken like opening the windows or tuning the air blower on or unlocking the car doors. After the required actions taken, they are tested, that is, this system will check if the windows are opened or not, or if the air blower is blowing air or not. The flow chart is mention to shows how this system actually works.

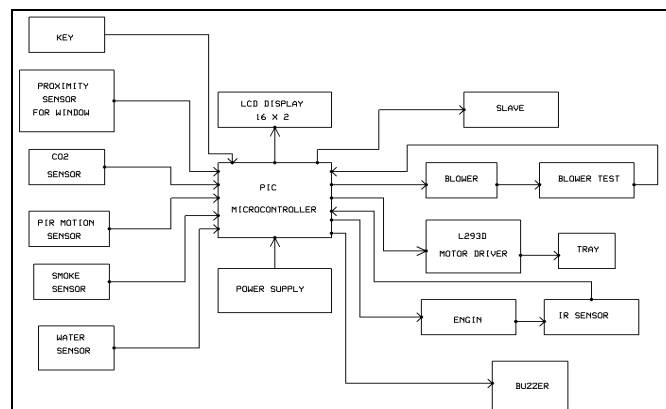

Fig -1: Block diagram of proposed system with slave.

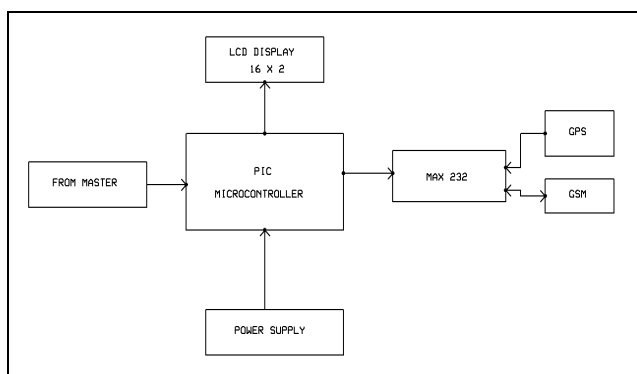

Fig -2: Block diagram of slave.

3.2 Micro-controller:

The micro-controller PIC is interfaced with a PIR motion sensor that gets activated as soon as the car's power is off and the car is locked, creating a closed cabin. It watches for a living being in the car. If it finds one then it sends signal to the micro-controller. The micro-controller activates CO₂ sensor, water sensor and smoke sensor which will monitor the CO₂ level, water level and smoke in the car.

In module one, if the CO₂ level increases and reaches to 0.1% of carbon dioxide in car, then the CO₂ sensor sends signal to micro-controller. The micro-controller sends signal to GSM module with the data taken from GPS for creating an alert message containing location of the car. The micro-controller will start a timer of 5 minutes. If the user sends "windows" or "air blower" as reply the according the mechanism will be performed and the micro-controller will send signal of deactivation to both the sensors. But if this doesn't happen then it will take the windows down using DC motor. If the window mechanism fails, then the micro-controller will turn on air blower and if this also fails then buzzer will be on and will signal the GSM module to send an urgent message.

In module second, as soon as the water sensor is activated and if it detects water on all the four sides of car for a constant period of time (say 1minute to 4 minutes), then it will automatically turn on the windows and will unlock the car so that the human being or pet will be rescued. If this mechanism fails then an alter message will be send to the nearby hospital and police station so as to save them.

In module third, when the smoke sensor is activated, it will sense for smoke. Suppose it senses smoke in car it will open the windows.

3.3 Living Being Detection (PIR Motion Sensor):

PIR senses motion and is always used to detect if a living being is present or not. They are small in size, cheap in cost; low-power, easy to use and they don't wear out.

This sensor will monitor the presence of living being for 10 minutes. If it finds one in the closed cabin within 10 minutes then it will send signal to the micro-controller to activate CO₂ sensor, water sensor, and smoke sensor. If it doesn't find any living being then it will shut itself down.

3.4 Carbon Dioxide Sensor (MQ7):

The carbon dioxide (CO₂) sensor is MQ7 sensor. This sensor is a Carbon Monoxide (CO) sensor, which senses Carbon Monoxide concentrations (in PPM) in the air. It measures CO concentration ranging from 20 to 2000 ppm. It has fast response time and is highly sensitive. The MQ7 sensor gives output in analog signals. The sensor can be used to detect different gases contains CO; it is cheap in cost [16].

As the sensor has a range of 20 ppm to 2000 ppm, there will be two levels where the proposed system will take

action. The first level will be at 0.1% of CO₂ (400 ppm – 1000 ppm) and the second level will be at 0.2% of CO₂ (1000 ppm – 2000ppm). As soon as the sensor strikes to 0.1%, the signals will be send to micro-controller through analog to digital converter. If the level of carbon dioxide (CO₂) rises to 0.2% then it will again send the signals to the micro-controller. It will keep on monitoring till it receives a signal from micro-controller about deactivation.

As an alternative we can use oxygen sensor but from the experimental point of view, carbon dioxide sensor should be preferred.

3.5 Water level detection Sensor:

As the news read that a lawyer was trapped inside the car due to flood and met with tragic death. The reason behind this was suffocation. In 2005, 627 people died due to the same reason [15].

When the water level increases up to the engine of car, it automatically locks the doors. Mainly, flood or tsunami is the problem faced by the people in the cities like Mumbai, and for this, they have found their own solution, i.e. to keep a hammer with them while they drive a car.

Hence this problem can be solved using IoT. The proposed system will sense the water on each side of car (four sides). If the system senses it continuously for one minute then the windows will be opened and the doors will be unlocked. If this mechanism fails then an alter message will be send to the pre-defined contact numbers, nearby police station and nearby hospital.

3.6 Smoke Sensor:

It is found that the current youth smokes cigarette in car with closed windows. This could lead to set the inside things on fire. Hence to prevent such accident, the smoke sensor can be used in car. As soon as the sensor senses smoke in car it will open the windows.

3.7 GSM (Global Service for Mobile Application) Modem and Electronic Alerting Message:

The modem will be controlled by a micro-controller through AT command set. AT command set is instruction used to control the modem. A standard SIM card can be inserted in the integral card-holder within the metal enclosure. Using this GSM modem, alter messages will be send, when required, to the pre defined numbers, hospital and/or police station.

3.8 GPS- Global Positioning System:

A GPS tracking system is based on the Global Navigation Satellite System (GNSS) network. This network helps a wide range of satellites which use microwave signals, transmitted to GPS devices, to give information on location,

vehicle speed, time and direction. GPS devices are generally used to record the position of vehicles as they make their journeys. Some systems send the information to a centralized database or system via a modem within the GPS system unit on a regular basis. This is known as active tracking or 2-Way GPS.

3.9 Window Mechanism:

For windows the power is fed to the driver's door through a 20-amp circuit breaker. The power is supplied to the window-switch control panel, placed on the door, and is distributed to a contact, present in the centre of each of the four window switches. Two contacts, one on either side of the power contact, are connected to the vehicle ground and to the motor. When the driver presses a window switch, one of the two side contacts is disconnected to the ground and one gets connected to the centre power contact, while the other is kept grounded. This provides power to the window motor. If the switch is pressed the other way, then power runs through the motor in the opposite direction. The external power supply is controlled by the micro-controller when the car's power is off.

4. Flowchart - Proposed Methodology:

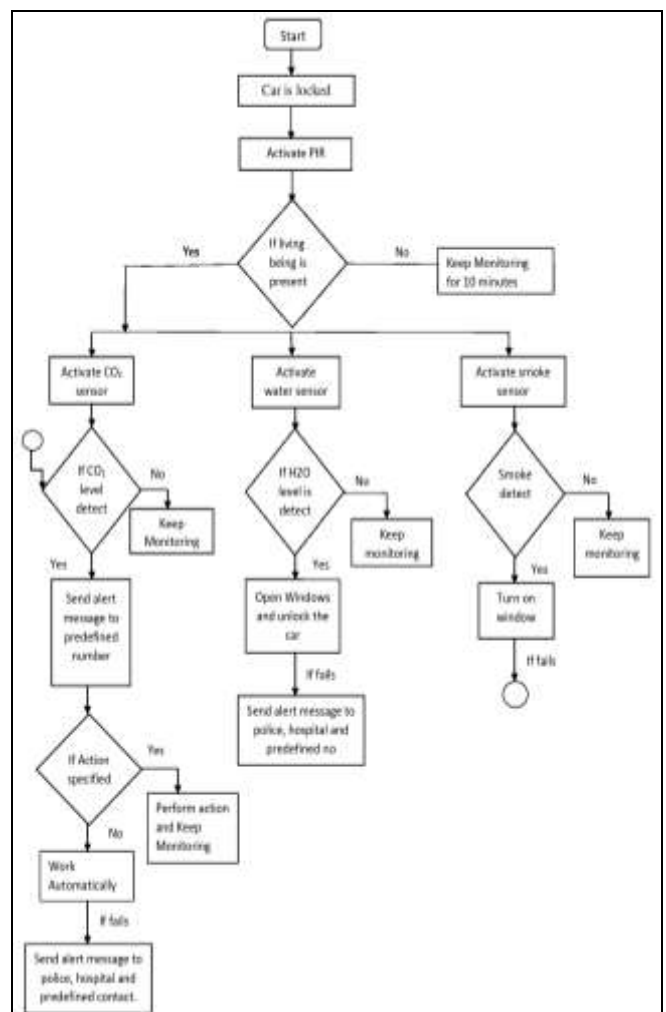

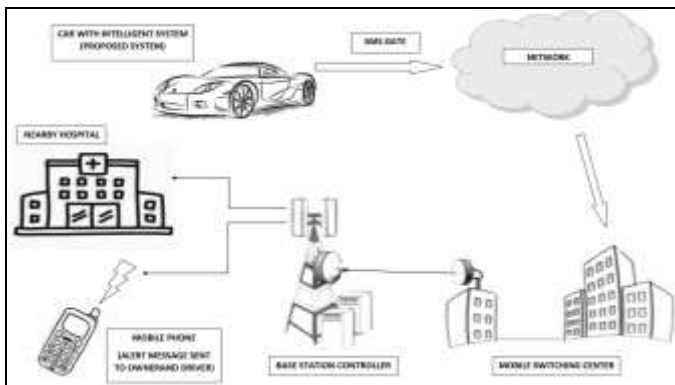

Fig -3: Architecture of Proposed System

5. CONCLUSION AND FUTURE SCOPE:

The motto of this proposed work is to save the loved ones from suffocation due to scarcity of oxygen in the closed car cabin. With the use of electronic devices, this intelligent system can be implemented. It will be low cost system that can be used in the smart cars for the mentioned reason. A small computer (micro-controller) will handle the decision making process and will open the connection for power supply to the power windows, air blower, buzzer and other sensors. This system helps the driver to know if there is anyone who is left in the car or the loved one is suffering from dearth of oxygen. It will also check if the person or the pet, in the car cabin, is having a critical situation, according to which an alert message will be send to the nearby hospital, and turn on the car buzzer to inform the nearby people about something wrong is happening in the car.

Foreseeing this system, a sensor can be developed which will scan the pulse rate or will measure the respiration rate fast with ease. This will not only tell the driver about the person suffocating in the car but will also inform if someone is having panic attack or any difficulty which rises his/her/it's respiration rates. Grace Wusk and Hampton Gabler proposed a system on car crash by detecting the respiratory rates and heart rates using seat sensor^[6]. Using this method, the proposed methodology can be enhanced for anti-suffocation in smart car systems.

REFERENCES

- [1] Aniket Kodre et al, "Smart and Efficient Personal Car Assistant System", 2018 IEEE.
- [2] Jetendra Joshi et al, Vehicle and Passenger Protection through Cooperative Sensor Based Vehicular Networking, Nov 2017 IEEE.
- [3] Chanda Nikhil Kumar, Madhavi Soni, Dr.R.Dineshkumar, "Anti-suffocation in Vehicles: Electronic Message Alert," Indian J.Sci.Res. 17(2): 325-328, 2018.
- [4] A. Rajendra Prasad, B. K.Rohit, V. Varun Kalyanaraman, S. Vasanth and S. Vignesh, "Prevention Of Air Suffocation Inside The Car Cabin Using A Mechatronic System," Volume 8, Issue 8, August 2017, pp. 738-747, Article ID: IJMET_08_08_081
- [5] Sangita N Gujar, Jagruti R Panchal , "Smart Car System Using Sensor, GPS And GSM ," ISSN 2319 - 2518 www.ijeetc.com Vol.3 , No. 3 , July 2014.
- [6] Grace Wusk and Hampton Gabler, "Non-Invasive Detection Of Respiration And Heart Rate With Vehicle Seat Sensor," Molecular Diversity Preservation International and Multidisciplinary Digital Publishing Institute Published: 8 May 2018.
- [7] <https://www.co2meter.com/blogs/news/what-is-a-room-oxygen-deficiency-monitor>
- [8] <http://www.hse.gov.uk/pubns/priced/eh40.pdf>
- [9] <http://www.autotap.com>
- [10] <http://www.quectel.com>
- [11] <https://www.ndtv.com/india-news/two-children-get-trapped-in-car-die-of-suffocation-in-maharashtra-2070403>
- [12] <https://www.dailymail.co.uk/news/article-5974859/Shocking-photos-distressed-Husky-locked-car-two-hours-suffocating-82F-heat.html>
- [13] http://timesofindia.indiatimes.com/articleshow/63459413.cms?utm_source=contentofinterest&utm_medium=ext&utm_campaign=cppst
- [14] <https://timesofindia.indiatimes.com/city/mumbai/mumbai-rains-young-lawyer-dies-hours-after-car-stalls/articleshow/60300792.cms>
- [15] <https://www.airthings.com/en-us/what-is-carbon-dioxide>
- [16] https://www.electroniccomp.com/mq7-gas-sensor?gclid=CjwKCAjwpuXpBRAAEiwAyRRPgUATejRjBRUPVFQVVFbHu0p6KJR0eAxXr-J94W-V2J4rrb-U12Wg_RoCmEQQAvD_BwE