

# Speed Governed Synchronous Generator Wind Power System with Remote Synchronization

Anand Unnikrishnan<sup>1</sup>, Niya Mary Joshy<sup>1</sup>, Mohammed Hafiz<sup>1</sup>, Manisha Mamman<sup>1</sup>, Thomas P Rajan<sup>2</sup>, Dr. Siny Paul<sup>3</sup>

<sup>1</sup>Student, Dept. of Electrical and Electronics Engineering, Mar Athanasius College of Engineering, Kothamangalam, Kerala, India

<sup>2</sup>Assistant Professor, Dept. of Electrical and Electronics Engineering, Mar Athanasius College of Engineering, Kothamangalam, Kerala, India

<sup>3</sup>Associate Professor, Dept. of Electrical and Electronics Engineering, Mar Athanasius College of Engineering, Kothamangalam, Kerala, India

\*\*\*

**Abstract** – This paper investigates the various disadvantages in the use of the conventional wind power system like the several power conversion stages of the synchronous generator system and reactive power consumption in induction generator system. This paper introduces the concept of using a synchronous generator as the integral component of the WECS, where the speed of the generator shaft will be controlled using a speed governing system which employs a Continuously Variable Transmission (CVT). Often, the location of wind farms in hilly and remote areas makes it difficult to monitor and control the system. A fault in the system will isolate the wind power system from the grid. Re-synchronization is a serious question before connecting the system back to the grid. A remote control on the wind power system is proposed which will enable an authorized user to monitor and control the wind power system from a remote control station.

**Key Words:** WECS, Synchronous Generator. Continuously Variable Transmission (CVT), Frequency control, Voltage control, Remote Synchronisation.

## 1. INTRODUCTION

By observing the present scenario in wind energy conversion system we can see that for the generation purpose the most commonly used generator is the induction generator. Wind energy is almost constantly and uncontrollably varying in speed. As per the reference [1], the induction generator is run at a slip not exceeding 1%. That is, a 4 pole induction machine which has a synchronous speed of 1500 rpm works in the range 1485 rpm to 1515 rpm. When using an induction generator there is a lot of reactive power requirement. Due to this there exists a need for using reactive power compensators, which in turn makes the system costlier. Grid excitation is also a necessary condition and it is not suitable in areas where grid connection is not available.

The use of synchronous generator came as an alternative method. But only a few manufacturers based on PMSG and WRSG were reported. This was because the use of synchronous generator requires several power conversion

stages for producing power of required frequency and voltage. Moreover, the synchronous generator is a constant speed machine which requires a speed governor to continuously run it at synchronous speed no matter how the wind speed changes. This paper describes a system using a Continuously Variable Transmission (CVT) as a speed governor for the synchronous generator. This idea was proposed 25 years ago as per reference [2] but did not yield the desired results at that time. Further developments were made in this field in terms of controller design, hydrodynamic control etc. as in the subsequent references. But most of it has proved to be highly complex. But the results obtained from all the studies guarantee the fact that using a CVT is an efficient method for speed governance for the operation of synchronous generator in WECS.

### 1.1 Continuously Variable Transmission

The Continuously Variable Transmission system is a technology used in gearless vehicles that provides an adjustable gear ratio which helps in maintaining a constant speed in the output shaft. There are various types of CVT available. The Variable Diameter Pulley has been used for the experiment which has been shown in the figure 1. In this most common CVT system, there are two V-belt pulleys that are split perpendicular to their axes of rotation, with a V-belt running between them.

The drive ratio is changed by moving the two sheaves of one pulley closer together and the two sheaves of the other pulley farther apart. The V-shaped cross section of the belt causes it to ride higher on one pulley and lower on the other. This changes the effective diameters of both pulleys, which changes the overall drive ratio. As the distance between the pulleys and the length of the belt does not change, both pulleys must be adjusted (one bigger, the other smaller) simultaneously in order to maintain the proper amount of tension on the belt.



Fig-1: Continuously Variable Transmission

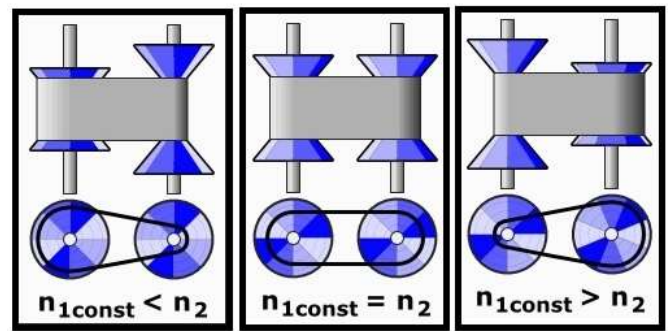

Fig-3: Working of CVT system

## 2. BLOCK DIAGRAM OF PROPOSED WECS

The block diagram of the proposed WECS using a CVT as the speed governor has been shown in Figure 2.

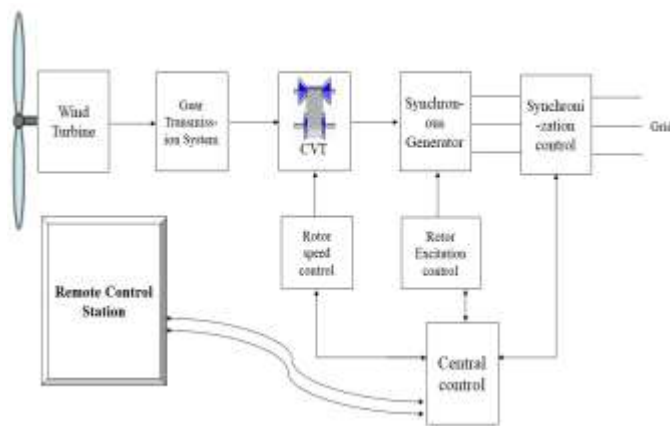

Fig-2: Block diagram of system

The various blocks and their indications are:

**Wind Turbine:** This is used for harvesting the wind energy. The wind energy rotates the wind turbine at a varying speed. This wind turbine could be a vertical axis or horizontal axis wind turbine. The turbine function is carried out by a dc motor. The varying wind speeds are brought about by the field current control of the dc motor.

**Gear Transmission system:** The speed of wind is very low compared to the rating of the generator. This speed adjustment is done by using the gear transmission system. The turbine output speed is geared up and given to the generator.

**CVT system:** It is added along with the existing transmission system to regulate the 1% slip (as mentioned earlier) in order to replace the induction machine with a synchronous machine. The ratio between the radii of the two pulleys determines the output speed and hence the frequency of the system. The working has been shown in figure 3.

**Rotor speed control:** A system is devised to continuously sense the output frequency of the machine and regulate the shaft speed using appropriate control over the CVT system. A frequency measurement circuit is designed to continuously monitor the output frequency of the system which is an indication of the speed of the alternator. A feedback is provided to the CVT control system.

**Rotor excitation control:** It regulates the generator output voltage by controlling the rotor excitation. This excitation control requires a feedback from the generator output ac voltage.

**Synchronization control:** Measures the parameters required for synchronization that is the voltage and the frequency of the generated power and the grid power and closes the circuit breaker after appropriate regulations.

**Remote Control Station:** It is a remote wind power synchronization system using a mini-computer with Wi-Fi module. Authorized personnel in a substation would continuously receive the measured data and have the provision for remote synchronization.

## 3. HARDWARE IMPLEMENTATION

The various key machines and devices with their specifications have been mentioned in the table 1.

Table -1: Components and specifications

COMPONENT	SPECIFICATION	QUANTITY
DC MOTOR (Wind Turbine)	220V, 2.7A ,0.6W, 1500 rpm, 50Hz	1
ALTERNATOR	12V, 43A	1
STEPPER MOTOR	12V, 2.8A ,10kgcm	2
CVT PULLEYS	Variable Diameter Pulley (VDP)	1
ARDUINO	Arduino UNO	1

### 3.1 Layout of the mechanical system

A mechanical system was developed on the basis of the block diagram. A DC motor was placed in the system instead of a

wind turbine to enable varying wind speeds by changing the field excitation. The CVT system was incorporated as a speed governor and a feedback of the output frequency was given to control the CVT ratio. The control system comprises of two stepper motors that are attached to the CVT and whose motion will move the sheave of the CVT in the desired direction and hence change the radius.

The basic layout with all the components is shown in the figure 4.

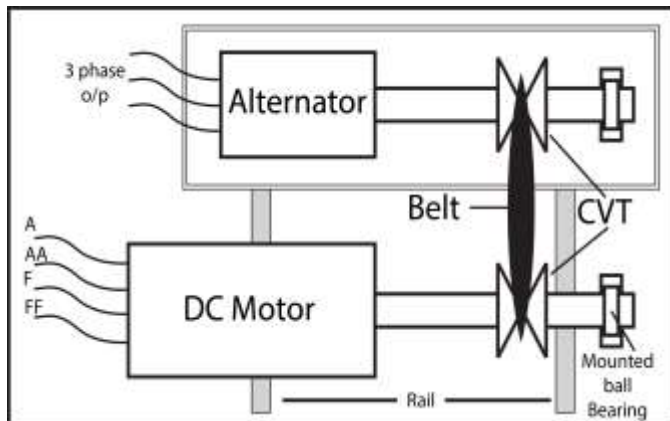

Fig-4: Basic layout of the system

The layout was kept as the basis and a mechanical structure was implemented which is shown in the figure 5.

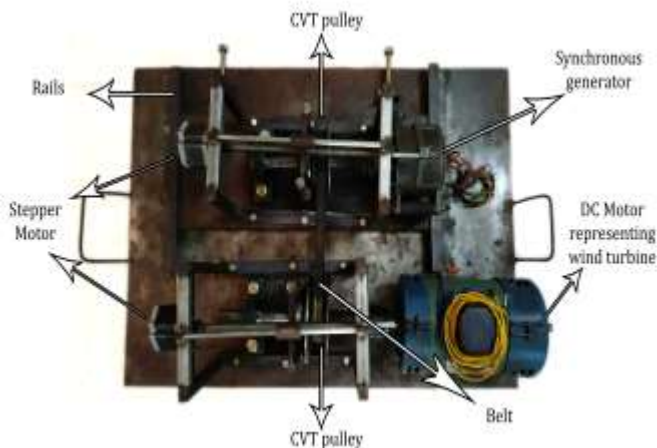

Fig-5: Final mechanical structure for experimentation

### 3.2 Analysis of the machine

The speed at which the alternator generates voltage at grid frequency was determined experimentally. From the equation  $N_s = 120f/P$ , it can be seen that the relation between speed and frequency of the machine is linear. A graph of frequency versus shaft speed was plotted which is shown in chart 1.

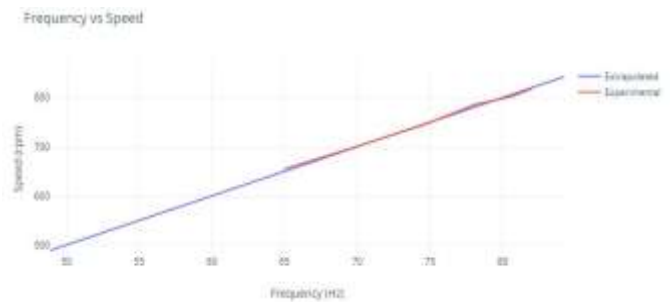

Chart-1: Graph of frequency versus shaft speed

The alternator is supposed to produce an AC at grid frequency (50 Hz) when the shaft is operated at a speed of 500 rpm as evident from the graph. Therefore, the gear ratio to be maintained is

$$r_2 / r_1 = N_2 / N_1 = 500 / 1500 = 1 / 3$$

Where,  $r_1$  is radius of driving pulley,  $r_2$  is radius of driven pulley,  $N_1$  is rated speed of DC motor and  $N_2$  is running speed of alternator.

### 3.3 Frequency control

The frequency of the generator output is continuously monitored using the frequency measurement circuit which employs a zero crossing detector as shown in the figure 6. The IC 741 has its inverting terminal grounded and the non-inverting terminal fed with the alternator output. A square wave is generated as the output goes to +5V during the positive half cycle and ground during the negative half cycle. The output of the zero crossing detector is fed to the Arduino UNO and the frequency is measured by observing the time period of one cycle. The frequency is found through the relation  $f = (1/T)$ .

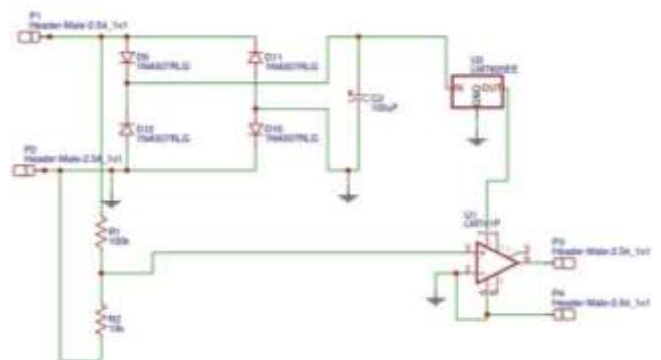

Fig-6: Frequency measurement circuit using op amp

Since the speed of the alternator is proportional to the frequency of output, the gear ratio can be regulated by sensing the output frequency of the alternator. In effect, the microcontroller which continuously senses the frequency at which the alternator generates power sends proper control signals to the stepper motor. This in turn drives the CVT pulleys in order to maintain proper gear ratio. Thus the shaft speed of the alternator is maintained constant thereby producing a constant frequency output.



### 3.4 Voltage Control

The output equation of the alternator is

$$E = 4.44 K_w \phi T f$$

where,  $K_w$  is the winding factor,  $f$  is the frequency in Hz,  $T$  is the no. of turns,  $\phi$  is flux per pole in Wb and  $E$  is the output voltage in volts.

From this equation it is evident that the output voltage is proportional to the field flux keeping the frequency constant. A rectifier circuit along with a step down converter as shown in figure 7 is used to control the rotor excitation of the machine.

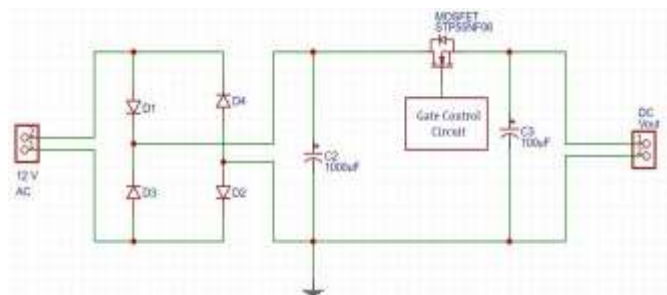

Fig-7: DC converter circuit

The gate of the MOSFET is controlled using a PWM firing circuit generated using 555 timer IC as shown in figure 8. The firing pulses are generated at a frequency of 30 kHz. The control voltage pin of the 555 timer IC is used to control the pulse width of the PWM signal. Thus, by applying a voltage to the control pin, the duty cycle of the PWM can be controlled. The PWM pin of the Arduino is used to apply the control voltage to the 555 IC which enables it to have a direct control over the rotor excitation of the machine. Appropriate control signals can be given from the Arduino by sensing the output voltage from the alternator.

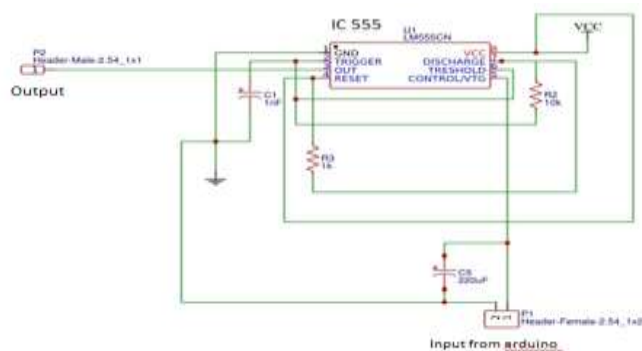

Fig-8: PWM circuit

### 3.5 Synchronization

The voltage and frequency signals are fed to the microcontroller which measures the output from the alternator. The frequency output of the alternator is maintained constant by controlling the distance between the CVT pulleys. These are controlled by sending appropriate

signals to the stepper motor. The voltage excitation of the machine is controlled by sending suitable voltages to the control voltage pin of the 555 timer IC which is used to generate the PWM signals. The grid voltage and frequency is measured and is set as the threshold to the microcontroller. Any variation from the threshold value is detected and appropriate control actions are taken to bring the alternator output to desired values.

### 4. SIMULATION RESULTS

The frequency detection circuit using the op amp was simulated using the Proteus software. The circuit which makes use of the op amp is shown in the figure 9 and the simulated output waveform which is a square wave whose positive peak is at +5 V and negative at ground potential is shown in figure 10.

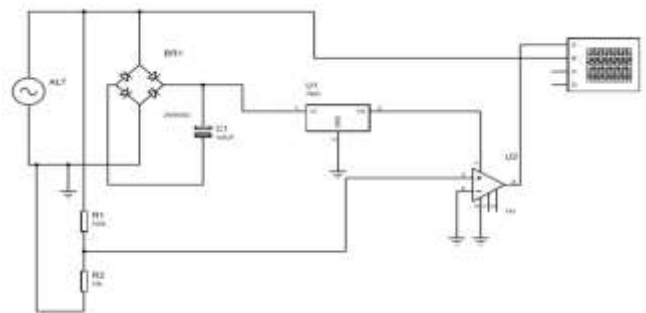

Fig-9: Simulation circuit of frequency detector

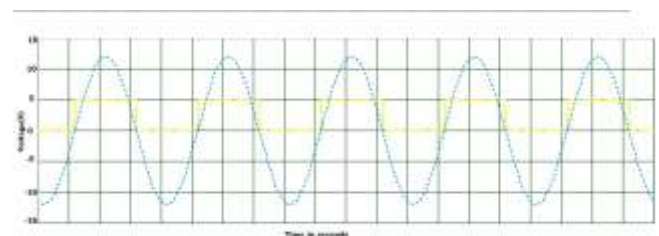

Fig-10: Simulation output waveform

The output waveform from the frequency detection circuit is fed to the Arduino to find its frequency. Through the Arduino program we find the time of running of the Arduino when the waveform makes its first transition from 0 (low) to 1 (high). Similarly, the time for the next set of similar transition is obtained. The time difference between the two is taken to find the frequency. This is simply depicted in the figure 11.

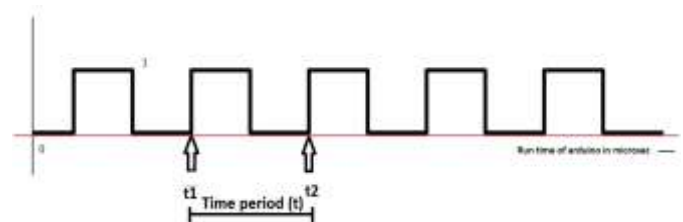
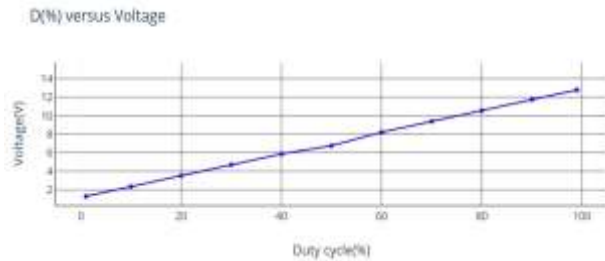

Fig-11: Method of frequency calculation

The PWM control circuit that was implemented was simulated using the MATLAB software. The duty cycle was varied and the corresponding voltages were observed. The chart 2 is the graph showing the variation of the voltage with the changing duty cycle. It can be observed that a voltage variation from 1.289 V (at 1% duty cycle) to 12.777 V (at 99% duty cycle) is possible.



**Chart-2:** Graph showing change in output voltage with change in duty cycle

## 5. CONCLUSION

A new model wind energy conversion system was implemented using CVT system. The speed governing was achieved by the stepper motor control of the ratio between the two CVT pulleys. The output voltage and frequency of the alternator was constantly monitored and send to a remote authorized personal. The frequency control was carried out by the CVT and the stepper motor whereas the voltage control was carried out by controlling the field excitation using a converter. The synchronization is carried out from a remote location after monitoring the voltage and frequency and matching it with the grid voltage and frequency.

## REFERENCES

- [1] E. Muljadi, M. Singh, V. Gevorgian, Fixed-speed and variable-slip wind turbines providing spinning reserves to the grid, in: 2013 IEEE Power & Energy Society General Meeting, IEEE, 2013, pp. 1–5.
- [2] H. Law, H. Doubt, Power control systems for the Orkney wind-turbine generators, GEC Engineering (2) (1984) 19–28.
- [3] H. Muller, M. Poller, A. Basteck, M. Tilscher, J. Pfister, Grid compatibility of variable speed wind turbines with directly coupled synchronous generator and hydro-dynamically controlled gearbox, in: Sixth International Workshop on Large-scale integration of wind power and transmission networks for offshore wind farms, 2006, pp. 307–315.
- [4] A. H. Rex, K. E. Johnson, Methods for controlling a wind turbine system with a continuously variable transmission in region 2, Journal of Solar Energy Engineering 131 (3) (2009) 031012.

- [5] C. Rossi, P. Corbelli, G. Grandi, W-cvt continuously variable transmission for wind energy conversion system, in: 2009 IEEE Power Electronics and Machines in Wind Applications, IEEE, 2009, pp. 1–10