

Efficiency Improvement and Performance Analysis of Solar Collector Using Nano fluids

Kumar Gaurav¹, C. Uthirapathy³

¹U.G. Student Dept. of Mechanical Engineering, SRM Institute of Science and Technology, Chennai, India

²Assistant Prof., Dept. of Mechanical Engineering, SRM Institute of Science and Technology, Chennai, India

Abstract - Solar storage tank is getting used worldwide for vasoconstrictor applications largely within the domestic sector for laundry garments and bathing functions. Thermo siphon flat plate solar storage tank may be a solar passive system, which may turn out plight within the temperature vary of 60–90 computers. The warmth transfer constant, outlet temperature and entropy generation among four totally different Nano fluids like Cu water, Al₂O₃ water, TiO₂ water and SiO₂ water provided attention-grabbing results concerning the result of Nusselt range, Bejan range, density, heat capability and potency on the performance of a solar dish. Similarly, a theoretical study on the performance of Al₂O₃ water nanofluid during a flat plate solar storage tank was analyzed for various particle sizes and volume fractions; conjointly the result of Prandtl range on flow and warmth transfer was analyzed exploitation FEM technique.

Key Words: Solar flat plate collector, Nano fluids, absorber tubes, flat plate collector, efficiency.

1. INTRODUCTION

Flat-plate collectors are the foremost common solar thermal technology. They carries with it an

(1) Enclosure containing

(2) A dark coloured absorbent plate with fluid circulation passageways, and

(3) A clear cowl to permit transmission of solar power into the enclosure. A fluid is circulated through the absorber's fluid passageways to get rid of heat from the solar dish. The circulation fluid in tropical and sub-tropical climates is often water. In climates wherever temperature reduction is probably going, a heat-transfer fluid almost like AN automotive liquid answer could also be used rather than water, or in an exceedingly mixture with water. If a heat transfer fluid is employed, a device is often utilized to transfer heat from the solar dish fluid to a predicament tank. The foremost common absorbent style consists of copper conduit connected to thermally conductive copper or Al fins. A dark coating is applied to the sun-facing facet of the absorbent assembly to extend it absorption of solar power. A typical absorbent coating is flat black enamel paint. In higher performance solar dish styles, the clear cowl is tempered glass with reduced iron compound content (the inexperienced color visible once viewing a pane of sheet glass from the side). The glass may additionally "have a stippling pattern AN anti-reflective coating to entice a lot of

solar power by reducing reflection.

Absorbent piping configurations include:

- arp – ancient style with bottom pipe risers and high assortment pipe, utilized in low thermo siphon and pumped up systems;
- flooded absorbent consisting of 2 sheets of metal sealed to supply a circulation zone;
- physical phenomenon absorbent collectors consisting of many layers of clear and opaque sheets that change absorption in an exceedingly boundary layer.

As a result of the energy is absorbed within the physical phenomenon, heat conversion could also be a lot of economical than for collectors wherever absorbed heat is conducted through a cloth before the warmth is accumulated in an exceedingly current liquid. Polymer flat plate collectors are an alternate to metal collectors and are currently being created in Europe. These could also be completely compound, or they'll embody metal plates before of freeze-tolerant water channels manufactured from synthetic rubber. Polymers are versatile and thus freeze-tolerant and may use plain water rather than liquid, in order that they'll be measured directly into existing water tanks rather than needing heat exchangers that lower potency. "By" dispensing with a device, temperatures needn't be quite thus high for the circulation system to be switched on, thus such direct circulation panels, whether or not compound or otherwise, may be a lot of economical, significantly at low lightweight levels. Some early by selection coated compound collectors suffered from heating once insulated, as stagnation temperatures will exceed the polymer's freezing point. For instance, the freezing point of plastic is a hundred and sixty °C (320 °F), whereas "the stagnation temperature of insulated thermal collectors" will exceed a hundred and eighty °C (356 °F) if management ways aren't used. For this reason plastic isn't usually utilized in glazed by selection coated solar collectors. More and more polymers like high temperate silicones (which soften at over 250 °C (482 °F)) are getting used. Some non-plastic compound based mostly glazed solar collectors are matte black coated instead of by selection coated to scale back the stagnation temperature to a hundred and fifty °C (302 °F) or less.

2. DESIGN

Solar Water Heater Design Consideration

Assumptions

1. Water Consumption
2. Inlet Temperature of water
3. Ambient Temperature
4. Inclination of Collector
5. Wind Speed
6. Fluid to heat transfer Coefficient.

Characteristics of Collector-

1. Collector efficiency - the ratio of useful 'gained thermal energy for period of to the solar radiation incident onto the collector for the same time period.
2. Pressure Drop - the difference in pressure between the inlets to the collector the outlet due to circulation friction.
3. Stagnant Conditions is characterized by no fluid circulation inside collector the period in which the absorbing surface area receives a considerable incident radiation.
4. Incidence Angle Coefficient - the ratio of optical efficiency of solar with fixed beam angle of incidence to the optical efficiency of the collector at its normal.
5. Collector Efficiency Factor -the ratio of the real energy output of collector to the energy output in. the case when the total 'absorber area was at average fluid temperature with same fluid quantity of flowing water.
6. Collector Flow Factor- It is the 'ratio of energy that collector can deliver at average temperature of the fluid to energy that the' collector can supply at the inlet collector temperature.
7. Collector Heat Removal Factor - It is the ratio of energy 'collector output to energy output of the collector in temperature of the inlet fluid. It is temperature dependent.
8. Collector Heat -Loss Coefficient - Coefficient of thermal'loss of collector is defined as ratio of temperature difference per unit area of the cover to the' ambient temperature.
9. Incidence Angle Coefficient - The ratio 'of optical efficiency of solar collector with fixed beam angle of incidence to optical efficiency 'of collector at its normal.
10. Acceptance angle - the angle through which a source of light can be moved and still converge at the receiver (Hsieh, 1986). A concentrator 'with small acceptance angle is required to track the sun continuously while. A concentrator with large acceptance angle needs only seasonal adjustment.
11. Absorber area is total area of the 'absorber surface that receives the concentrated solar radiation.
12. Concentration ratio(C) is defined as the ratio of the

aperture area 'to the absorber area i.e. C the optical potency is outlined because the magnitude relation of the energy absorbed by the absorbent material to the energy incident on the concentrator aperture.



Fig -1: 2D view of setup

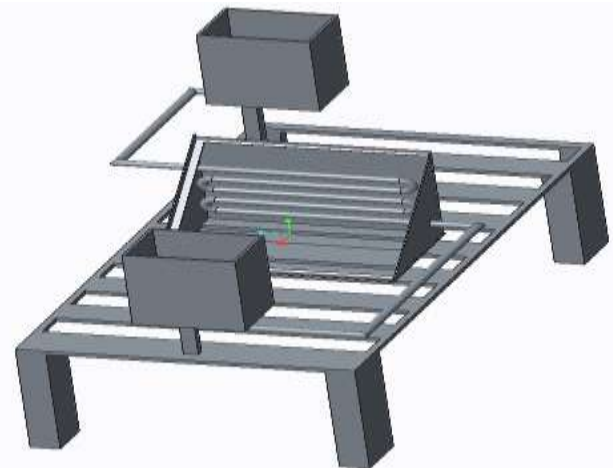

Fig -2: Circular tube setup

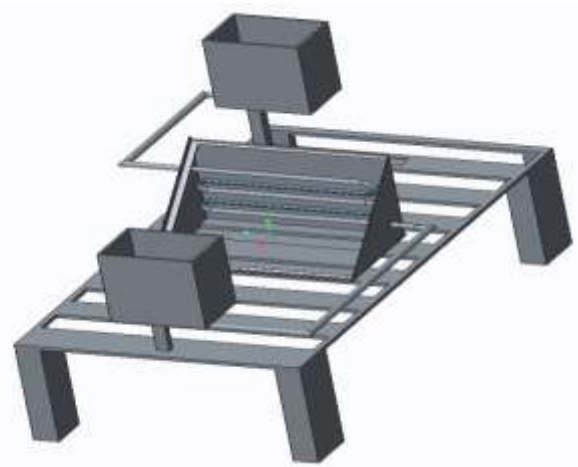

Fig -3: Triangular tube setup

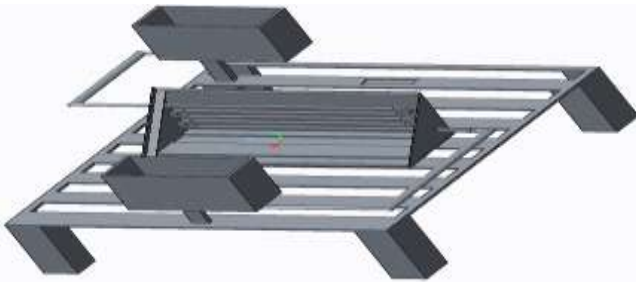

Fig -4: Square tube setup

3. FABRICATION PROCEDURE

Step 1: A steel plate was taken and cut into required dimensions.

Step 2: The cut pieces were then welded to form containers which would later act as inlet and outlet water storage, where the initial and final temperatures of the water and aluminum oxide solution i.e. Nano fluid would be measured and noted.

Step 3: The copper pipes are taken and altered the shapes in order to fit the experiment requirement of absorber tube of different geometry. The absorber tube is heated and then forged into square tube. The brazing operation was also done in case of triangular tube. The different geometry will increase the efficiency of the solar collector which is mainly due to the difference in surface area.

Step 4: The solar component which is the main component containing the absorber tubes is then fabricated. The length and breadth of the collector is 14.5 inches and 12 inches respectively.

Step 5: The solar collector is fabricated in such a way such that there is a glass cover at the top under which black aluminum sheet is kept.

Step 6: The absorber tubes are then covered with wool so as reduce heat dissipation thus acting as insulation. A stop cock is fitted at the exit of the solar collector to regulate the flow of water and also to note the readings periodically.



Fig -5: Experimental setup

4. ANALYSIS

The objective of gift study is to perform CFD simulation and fabricate the reflector. The results obtained by CFD simulation are validated with experimental results. The experimental conditions 'taken for solar air collector, a similar has been used for CFD simulation. The general aim of work is grasp the flow behavior and temperature distribution of air within the reflector and compares the outlet 'temperature of air with experimental results.

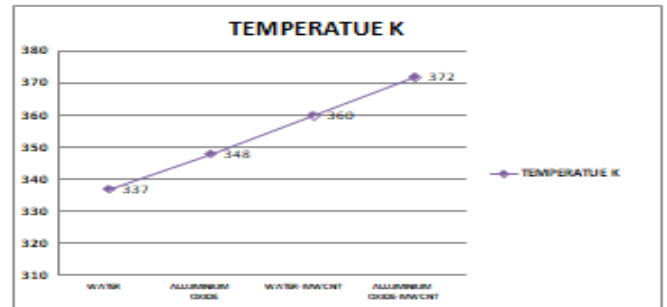

Fig -6: Temp VS Nano Fluids

4.1. CIRCULAR

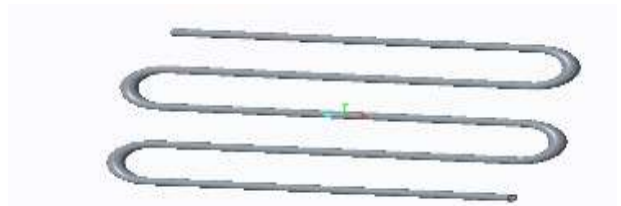

Fig -7: Circular absorber tube

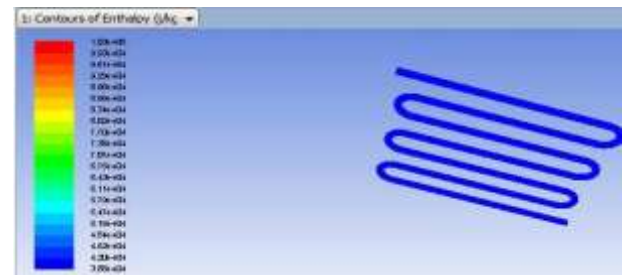

Fig -8: Experimental setup

4.2. TRIANGULAR



Fig -9: Triangular absorber tube



Fig -10: Experimental setup

4.3. SQUARE



Fig -11: Square absorber tube

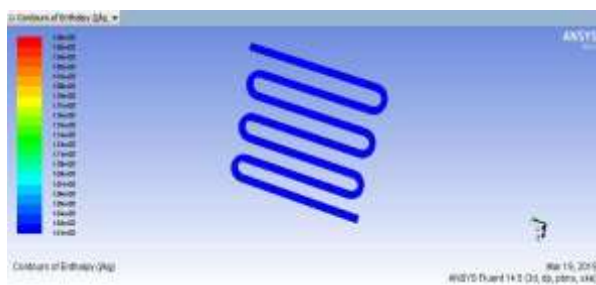

Fig -12: Experimental setup

5. TESTING

Inlet temperature of the water and temperature of the hot water in the storage tank were tabulated on hourly basis, both the collector efficiency of the collectors were calculated.

5.1. TRIANGULAR TUBE

TABLE -1: OBSERVATION (USING WATER AS WORKING FLUID)

S.No	I.S.T hours	Inlet temperature Ti (in °C)	Outlet Temperature To (in °C)
1	8.00	25	26
2	9.00	26	31
3	10.00	26	35
4	11.00	27	43
5	12.00	28	46
6	13.00	29	49
7	14.00	30	48

TABLE -2: OBSERVATION (USING AL₂O₃ AS WORKING FLUID)

S.No	I.S.T hours	Inlet temperature Ti (in °C)	Outlet Temperature To (in °C)
1	8.00	25	27
2	9.00	25	33
3	10.00	26	36
4	11.00	26	45
5	12.00	27	47
6	13.00	28	50
7	14.00	30	48

5.2. CIRCULAR TUBE

TABLE -3: OBSERVATION (USING WATER AS WORKING FLUID)

S.No	I.S.T hours	Inlet temperature Ti (in °C)	Outlet Temperature To (in °C)
1	8.00	25	25
2	9.00	26	30
3	10.00	26	34
4	11.00	27	41
5	12.00	28	43
6	13.00	29	47
7	14.00	30	46

TABLE -4: OBSERVATION (USING AL₂O₃ AS WORKING FLUID)

S.No	I.S.T hours	Inlet temperature Ti (in °C)	Outlet Temperature To (in °C)
1	8.00	25	26
2	9.00	25	32
3	10.00	26	35
4	11.00	26	44
5	12.00	27	46
6	13.00	27	50
7	14.00	30	47

5.3. SQUARE TUBE

TABLE -5: OBSERVATION (USING AL₂O₃ AS WORKING FLUID)

S.No	I.S.T hours	Inlet temperature Ti (in °C)	Outlet Temperature To (in °C)
1	8.00	25	26
2	9.00	25	34
3	10.00	26	37
4	11.00	26	43
5	12.00	27	45
6	13.00	28	49
7	14.00	30	46

TABLE -3: OBSERVATION (USING WATER AS WORKING FLUID)

S.No	I.S.T hours	Inlet temperature Ti (in °C)	Outlet Temperature To (in °C)
1	8.00	25	25
2	9.00	26	30
3	10.00	26	34
4	11.00	27	42
5	12.00	28	44
6	13.00	29	47
7	14.00	30	45

6. CALCULATION

Calculation of Instantaneous Efficiency

Constant Terms:-

- Length of the absorber plate 'L' = 14.5 inches
- Breadth of absorber plate 'B' = 12 inches
- I.S.T (When reading was taken) = 11.00 Hrs.
- Location of Chennai = 13.0827° N, 80.2707° E
- I.S.T Longitude = 82.5 degree East
- Date of experiment = 8th and 9th April 2019

Collector is facing due south

Mass flow rate = 0.5 LPM

Variable Terms:-

- Inlet temperature of water = X° C
- Outlet temperature of water = X° C
- Angle of tilt = X°

Average Solar irradiation on earth (in terms of energy) R = 900 W/m² Hr.

Solar irradiation on earth in 7 hours (in terms of energy) R = 900*7 W/m² day

R = 6300 Wh /m²

R = 22680000 W Sec/m², where

A = Area of Flat plate collector in m²

T₁ = inlet temperature (in °C)

T₂ = outlet temperature (in °C)

Specific heat of water = 4.182 KJ KG °K

Area of the flat plate collector,

$$A = L \times W \text{ m}^2 = 14.5 \times 12 \text{ inches} = 0.114 \text{ m}^2$$

$$Q = MC_p (T_2 - T_1)$$

$$\eta = \frac{Q}{R \times A}$$

For Triangular tube:-

$$Q = 100 \times 4.187 \times 103 (47 - 27) = 837400000 \text{ J}$$

$$\eta = (837400000 / 23014700) = 36\%$$

For circular tube:-

$$Q = 100 \times 4.187 \times 103 (44 - 28) = 669920000 \text{ J}$$

$$\eta = (669920000 / 23014700) = 29\%$$

For square tube:-

$$Q = 100 \times 4.187 \times 103 (48 - 27) = 628050000 \text{ J}$$

$$\eta = (628050000 / 23014700) = 27\%$$

7. RESULT AND DISCUSSION

This paper bestowed a review of the nanofluid applications in solar thermal engineering. The experimental and numerical studies for solar collectors showed that in some cases, the potency may increase remarkably by victimization nanofluids. Of course, it's found that employing a nanofluid with greater volume fractionation, always isn't the simplest possibility. Therefore, it's instructed that the nanofluids in numerous volume fractions ought to be tested to search out the optimum volume fraction. it's additionally seen that the out there theoretical works provide totally different results on the results of particle size on the potency of collectors. It's price to hold out associate experimental work on the result of particle size on the collector potency. From the economic and environmental purpose of read, the previous studies showed that victimization nanofluids in collectors ends up in a discount in greenhouse emission emissions and annual electricity and fuel savings. Another reportable works of the application of the nanofluid in solar cells, solar thermal energy storage, and solar stills are reviewed. It's in addition stressed that for study of solar system (example cooling of solar cells), it's higher to use new thermo physical (temperature-dependent) model along with a pair of half mixture model for the nanofluid to possess a plenty of precise prediction of system performance. Finally, the foremost necessary challenges on the utilization of the Nano fluid in solar systems as well as high prices of production, instability and agglomeration issues, inflated pumping power and erosion square measure mentioned. These challenges are also reduced with the event of technology within the future.

REFERENCES

- [1] S. M. Metev and V. P. Veiko, *Laser Assisted Microtechnology*, 2nd ed., R. M. Osgood, Jr., Ed. Berlin, Germany: Springer-Verlag, 1998.
- [2] J. Breckling, Ed., *the Analysis of Directional Time Series: Applications to Wind Speed and Direction*, ser. Lecture Notes in Statistics. Berlin, Germany: Springer, 1989, vol. 61.
- [3] S. Zhang, C. Zhu, J. K. O. Sin, and P. K. T. Mok, "A novel ultrathin elevated channel low-temperature poly-Si TFT," *IEEE Electron Device Lett.*, vol. 20, pp. 569–571, Nov. 1999.
- [4] M. Wegmuller, J. P. von der Weid, P. Oberson, and N. Gisin, "High resolution fiber distributed measurements with coherent OFDR," in *Proc. ECOC'00*, 2000, paper 11.3.4, p. 109.
- [5] R. E. Sorace, V. S. Reinhardt, and S. A. Vaughn, "High-speed digital-to-RF converter," U.S. Patent 5 668 842, Sept. 16, 1997.
- [6] (2002) The IEEE website. [Online]. Available: <http://www.ieee.org>
- [7] M. Shell. (2002) IEEEtran homepage on CTAN. [Online]. Available: <http://www.ctan.org/tex-archive/macros/latex/contrib/supported/IEEEtran>
- [8] FLEXChip Signal Processor (MC68175 D), Motorola, 1996.
- [9] "PDCA12-70 data sheet," Opto Speed SA, Mezzovico, Switzerland.
- [10] A. Karnik, "Performance of TCP congestion control with rate feedback: TCP ABR and rate adaptive TCP IP," M. Eng. thesis, Indian Institute of Science, Bangalore, India, Jan. 1999.
- [11] J. Padhye, V. Firoiu, and D. Towsley, "A stochastic model of TCP Reno congestion avoidance and control," Univ. of Massachusetts, Amherst, MA, CMPSCI Tech. Rep. 99-02, 1999.
- [12] *Wireless LAN Medium Access Control (MAC) and Physical Layer (PHY) Specification*, IEEE Std. 802.11, 1997.