

Portable Groundnut Stripper

Bhanuprakash H S¹, Harish D S², Karthik G C³, Sahebagoth.Sanganagoudar⁴

¹Assistant Professor, Dept. of Mechanical Engineering, Mangalore Institute of Technology & Engineering, Moodabidri, Karnataka, India

²Project Engineer, Teknion, Bangalore, Karnataka, India

³Assistant Professor, Dept. of Mechanical Engineering, Rajeev Institute of Technology, Hassan, Karnataka, India

⁴Assistant Professor, Dept. of Mechanical Engineering, VSM Institute of Technology, Nipani, Karnataka, India

Abstract - This project aims at design and fabrication of Portable Groundnut Stripper. The proposed project is intended to separate the groundnuts from the groundnut plant. The machine has one slider, stepper metal blade, AC motor, one metal plate with holes and one metal plate without holes, supporting stand for motor, wheels for easy movement of the machine. In this machine the groundnut plant will feed to the blades with the help of slider by manually. Then the rotating blades will separate the groundnuts from the plant by cutting their smooth roots. Later the groundnuts will drop on the inclined metal plate which has several holes, then all the wastage will go out through the holes and only good quality groundnuts will come out. So, this machine will vanish the labourers problem. Therefore, it is a time saveable machine. And it is very small in size and it has very less weight so, it is very easy to carry the machine from one place to other place. Hence, this machine is most helpful to our farmers to get more profit.

Key Words: Groundnut, Pods, Portable, Stripper, labour problem, etc

1. INTRODUCTION

Groundnut is one of the major cash crops for India. It is grown in upland areas during rainy season (rainfed) and in lowland areas after paddy during dry season (irrigated). The most common practice for groundnut stripping in irrigated area is to strip within 1 or 2 days after harvesting. Stripping is done by picking pod by pod with an average capacity of 25 kg of pod per man-day. The major reasons for the demand for groundnut machinery are to reduce drudgery, to reduce time consumption, and to increase productivity and income

1.1 Manual Lifting Process

The groundnut plants are annually harvested by being pulled or dug up. This is usually called 'lifting'. There are various designs of equipment available to assist in lifting groundnuts. Manual lifting and machine lifting. In manual lifting, the groundnut plant is lifted by the effort of people.

2. CONSTRUCTION AND WORKING

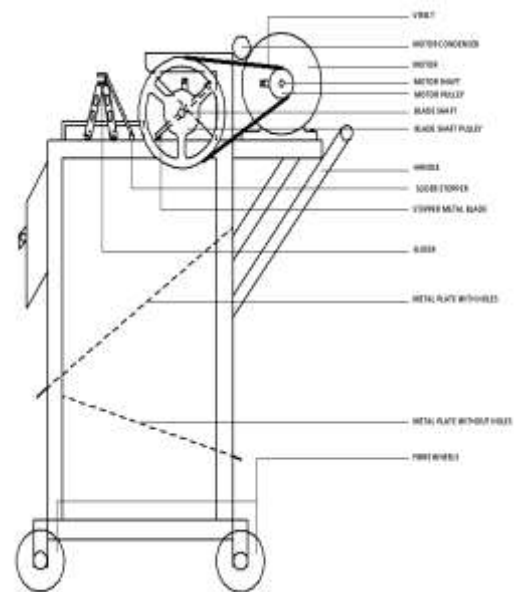

Fig -1: Portable Groundnut Stripper

The machine has one slider, stepper metal blade, AC motor, one metal plate with holes and one metal plate without holes, supporting stand for motor, wheels for easy movement of the machine.

The motor is placed on the motor stand and the power is transmitted to the blade shaft with the help of pulleys and v-belt. The shaft is rigidly fixed with the help of bearings. The rectangular stepper blades are welded to the shaft. The slider is placed on the top in front of the rotating blades. The metal plate with and without holes are inclined to certain angle and welded. The wheels are attached to the body of the machine at the bottom. The electrical wiring is made for proper flow of electricity to the motor.

In this machine the groundnut plant will feed to the blades with the help of slider by manually. Then the rotating blades will separate the groundnuts from the plant by cutting their smooth roots. Later the groundnuts will drop on the inclined metal plate which has several holes, then all the wastage will go out through the holes and only good quality groundnuts will come out

Table -1: Comparison between Earlier Groundnut Strippers and Newly Designed Portable Groundnut Stripper

Sl. No.	Earlier Groundnut Strippers	Newly Designed Portable Groundnut Stripper
1.	High initial cost	Less initial cost
2.	High maintenance cost	Low maintenance cost
3.	Less efficiency	High efficiency
4.	Larger in size	Smaller in size
5.	Damage of pods will occur	No damage of pods
6.	They have no device for filtering the pods	It has inclined metal plate with holes for filtering

2.1 Results of Performance Study

1. The Portable Groundnut Stripper will strip 40-50 kg of groundnuts per hour with the cost of 5-6 rupees.
2. Only one man is sufficient to operate the machine. Hence reduce labourers problem.
3. It will produce good quality groundnut pods.
4. The motor has a capacity of running continuously upto 3 hours.
5. The machine has a weight of 30 kg. Hence it is portable.
6. It has major application in agriculture field

3. CONCLUSIONS

By using this machine only one man can do the work of five to six peoples. So, this machine will vanish the labourers problem. Therefore, it is a time saveable machine. And it is very small in size and it has very less weight so, it is very easy to carry the machine from one place to other place. This machine will helps to the farmers to get rid of the earlier problems in groundnut stripping process and it will increases the productivity of groundnut and income of farmers. Hence it is most useful to the field of agriculture.

REFERENCES

[1] S. Ghatge, P. S. Bandgar & S. A. Mehtre, "Development and Performance Evaluation of Pedal Operated Groundnut Pod Stripping Machine", International Journal of Agricultural Engineering, (April 2014). Volume (7), Issue 1, PP 217-220.

[2] Ashok S Andhale, Sayed Wajahat, Pranav Lawhale, Kunan Mendhe, "Design and development of groundnut pod separating machine", International Journal of Latest Engineering and Management Research(IJLEMR), ISSN:2455-4847, April 2017 Volume(2) , Issue 4, PP 38-40.

[3] Design of Machine Elements-II by Prof. J. B. K Das and P. L Srinivasa Murthy, fifth revised and enlarged edition, February 2010.

[4] G. Karthik, D. Balashankar, G. Rambabu, B. Nagabhushanam, Lvs Akhil, A. Lakshumu Naidu, "Design and Fabrication of Groundnut Pods and Shell Stripper", International Journal of Engineering Trends and Technology (IJETT), (April 2018). Volume (58) Issue 2, PP 60-64.

[5] Bishnupada Jana, "Prospects of Groundnut Cultivation", IJSRD - International Journal for Scientific Research & Development, (2016). Volume (4), Issue 05, ISSN (online): 2321-0613, PP 1667-1670.

[6] Rajasekar. M, Arunkumar.S, Divakar.S, Santhosh Kumar.R, "Design Fabrication and Performance Analysis of Groundnut Thresher", International Research Journal of Engineering and Technology (IRJET), Feb -2017, e-ISSN: 2395 -0056 p-ISSN: 23950072, Volume (04), Issue (02), PP 1631-1637.

BIOGRAPHIES



Working as Assitant professor in Mechanical Engineering department at Mangalore Institute of Technology & Engineering, Moodabidri, Karnataka, India. Member of ISTE.



Working as Project Engineer in Teknion, Bangalore, Karnataka, India.



Working as Assitant professor in Mechanical Engineering department at Rajeev Institute of Technology, Hassan, Karnataka, India.



Working as Assitant professor in Mechanical Engineering department at VSM Institute of Technology, Nipani, Karnataka, India.