

ADVANCE ATM SECURITY SOLUTION

Manisha Philip Dushing, Shashi Gera

¹Student, MTECH, NIELIT, Aurangabad, Maharashtra, India

²Professor Scientist E, NIELIT, Aurangabad, Maharashtra, India

Abstract - In today's modern era of technology, with increase in technological advancement there has been more ways to break in to the security and full high advance system, ATM can be robbed by brut entries and can be manipulated in the absence of the guards, with an effort to increase the security at ATM's we propose a system where we can counter such situations and create a more advance and secure system, This system will propose and secure method of providing a finger printer scanner at the entry of ATM doors for accessing the ATM machines ,when breached or tampered with trigger the alarm and will ping the local police line this system is high efficient and cost effective since the component used in this system are highly feasible and low cost.

Key Words: ATM, security, Arduino, PIR sensor, Finger print, Alarm

1. INTRODUCTION

The increasing no of ATM robbery made us think about this solution to overcome this problem. In the current situation only CCTV cameras and security guards are deployed at the ATM cabins. There are some rules to be followed to perform ATM transaction such as,

1. No Helmet/scarf/cap,
2. Use of mobile phone is prohibited,
3. Only one person at a time.

But what if these rules are not followed? In what ways the CCTV cameras will be helpful if someone covers his/her face by helmet/scarf/cap and does the tampering or damages the ATM? And we also know that a human security can be breached by threatening, bribing, influencing, etc. So that's why there is a need of new and advance security solutions to overcome such problems.

In this project we are restricting the entry of every individual at the ATM. The ATM cabin door will be locked & every person first have to scan the fingerprint on fingerprint module .Then the fingerprint provided will be matched with the database and if it matches then only the door will be unlocked. A data of every individual who got the access will be stored with date and time in the system. If anyone tries to get inside the ATM cabin without getting the access, by breaking the door or by some other means then the sensors will detect it & immediately a buzzer will be turned ON & an alert SMS would be send to the respective authority or the Police control room. The buzzer will be ON until the intruder leaves the premises or no movement it detected.

2. Hardware development

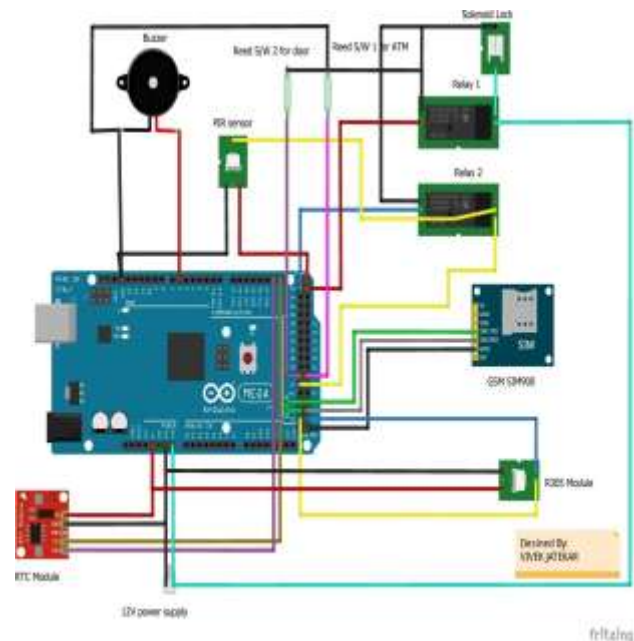

In this system, we have used Arduino mega as the processor and is the brain of this project, the first part is the PIR sensor that is an electronic sensor that measures IR light from obstacles in its field of view. They are commonly used in PIR motion detectors. PIR sensor allows you to sense movement, helps to identify whether any one has arrived at ATM door then the next point at Biometric Sensor R305 ,The Fingerprint Recognition Involves Snapping An Image Using A Fingerprint Scanner Which Is Then Digitally Compared With A Previously Stored Snapshot Of Your Fingerprint . The Scanner searches Whether the Loops Whorls and Curves Have any common pattern. An key point to be noted is that the finger print recognizer doesn't keep the complete image of your fingerprint. It only stores data about specific points in the form of binary numbers. This data when processed through the processor will identify the user checks whether he is author side to enter the ATM or not, if he has the authority he can access the ATM without any interruption else the buzzer will be turned On and alert SMS will be sent to local police line , whereas wen the user is identified through his finger print the date time details provided by RTC module will help will create a data log entry, this entry log is stored in the external memory card we provide to the Arduino board, while the entry is being registered the door is unlocked for 10 sec so the user can pass and access the ATM machine. In any case there and been an intrusion or

tampering with finger print sensor or ATM machine an SMS will be sent through the GSM module to the nearest helpline.

system can also be used at various places where access controlling has to be maintained and monitored.

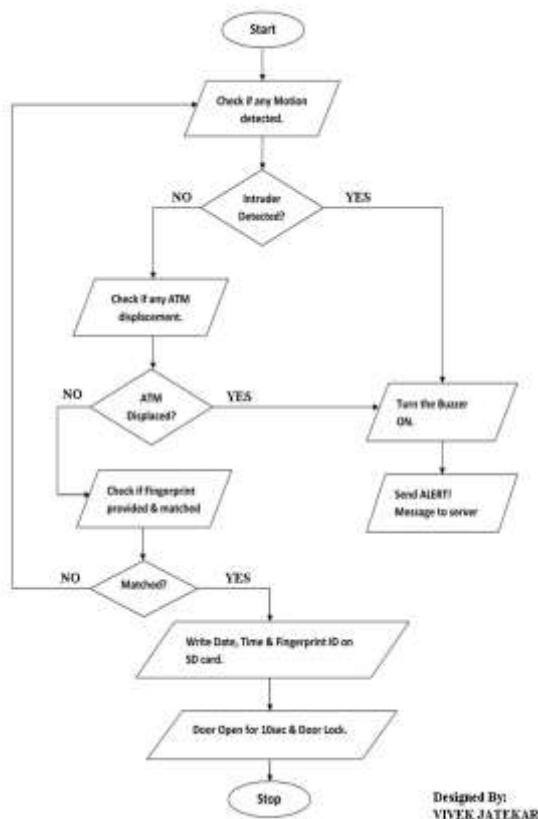

REFERENCES:-

1. Palash Kumar Bose1 , Mohammad Jubaidul Kabir2 Received: September 12, 2016 Accepted: December 7, 2016
2. Frimpong Twum , Kofi Nti Michael Asante, improving Security Levels In Automatic Teller Machines (ATM) Using Multifactor Authentication International Journal of Science and Engineering Applications Volume 5 Issue 3, 2016
3. Fingerprint Identification By Kuntal Barua, Samayita Bhattacharya, Dr. Kalyani Mali Global Journal of Computer Science & Technology Volume 11 Issue Version 1.0 April 2011 Type: Double Blind Peer Reviewed International Research Journal
4. Muhammad-Bello B.L, Alhassan M.E, Ganiyu, S.O An Enhanced ATM Security System using Second-Level Authentication International Journal of Computer Applications (0975 – 8887) Volume 111 – No 5, February 2015
5. Deepak G. Deshekar Smart ATM Security Using Mobile Messaging International Research Journal of Engineering and Technology (IRJET) Volume: 03 Issue: 07 | July-2016

3. CONCLUSION

As we all know, these days most of the ATM are been attacked by the robbers, as it seems to them an easy way to get money. It is a well-known saying; ‘Precaution is better than cure’ therefore we should take precautionary measures to avoid such things. There is a need for improving the security system after a period of time so as to be one step forward from such robbers always. This paper demonstrates how automation of ‘Advance ATM security system’ can be used to prevent robbery or damages to ATM by using GSM Technology, vibrating sensor, LED display, buzzer/siren, etc. at the cabins of ATM Machine. By implementing this project we can avoid robbery incidents and also chase robbers in a very short time span.

4. FUTURE SCOPE

The ATM security system safety has various techniques to avoid the robbery and ATM tampering problem. In future the security system can be advanced according to the requirements. In future we can enhance the system by adding retina scan, Palm scanner and other devices of biometric credential. More sensors such as temperature sensor, anti-break glass door sensor, etc. can be added to the system to ensure safety of the ATM. The most important thing is that people follow the rules and regulations related to this system to improve security of this approach. This