

# DUCT DESIGNING IN AIR CONDITIONING SYSTEM AND ITS IMPACT ON SYSTEM PERFORMANCE

Vishal Shah<sup>1</sup>, Prof. M.H. Patil<sup>2</sup>

<sup>1</sup>Student, Department of Mechanical Engineering, D.N.Patel COE, Shahada (M.H.)

<sup>2</sup>Professor, Department of Mechanical Engineering, D.N.Patel COE, Shahada (M.H.)

\*\*\*

**Abstract** - Earlier the use of air conditioning for comfort purpose was considered to be expensive, but now a-day; it has been a necessity for all human beings. Window air conditioners, split air conditioners are used in small buildings, offices etc. But, when the cooling load required is very high such as big buildings, multiplex, multi-story buildings, hospitals etc. centralized unit (central air conditioners) used. The central AC's systems are installed away from building called central plant where water or air is to be cooled. This cooled air not directly supplied to the building rooms. When the cooled air cannot be supplied directly from the air conditioning equipment to the space to be cooled, then the ducts are provided. The duct systems carry the cooled air from the air conditioning equipment for the proper distribution to rooms and also carry the return air from the room back to the air conditioning equipment for recirculation. When ducts are not properly designed, then it will lead to problem such as frictional loss, higher installation cost, increased noise and power consumption, uneven cooling in the cooling space. For minimizing this problem, a proper design of duct is needed. Equal friction method is used to design the duct, which is simple method as compared with the other design methods. These work gives the combination of theoretical and software tool to provide a comparative analysis of the duct size. It also gives the comparison between rectangular duct and circular duct.

**Keywords** – Equal friction method, friction loss, duct sizing.

## 1. INTRODUCTION

In the present day, as the population increases the need for comfortness also increases. The human being needs more comfortness because of inferior environment (like light, sound, machine which produce heat). Sound, light and heat affect human comfort a lot. They may adversely affect the human comfort positively or negatively. Researchers suggest that, human body is used to be comfortable at a temperature of 22°C to 25°C. When the temperature of room is lower or higher than this temperature, than the human body feels uncomfortable. This is because, the human body is structured in a way that, it should receive a certain amount of light, failure to which it can cause sunburns and other skin conditions.

There are many types of air conditioning system like window air conditioners, split air conditioners etc. but these AC's system are used in small room or office where cooling load required is low. When the cooling load required is very high like multiplex building, hospital etc. central AC's system are used. In central AC's system the cooled air is directly not distributed to the rooms. The cooled air from the air conditioning equipment must be properly distributed to rooms or spaces to be cold in order to provide comfort condition. When the cooled air cannot be supplied directly from the air conditioning equipment to the spaces to be cooled, then the ducts are installed. The duct systems convey the cold air from the air conditioning equipment to the proper air distribution point and also carry the return air from the room back to the air conditioning equipment for reconditioning and recirculation. As the duct system for the proper distribution of cold air, costs nearly 20% to 30% of the total cost of the equipment required. Thus, it is necessary to design the air duct system in such a way that the capital cost of ducts and the cost of running the fans is lower.

The chief requirements of an air conditioning duct system are:

1. It should convey specified rates of air flow to prescribed locations
2. It should be economical in combined initial cost, fan operating cost and cost of building space
3. It should not transmit or generate objectionable noise generally at the time of designing an air conditioning duct system, the required airflow rates are known from load calculations.

The location of fans and air outlets are fixed initially. The duct layout is then made taking into account the space available and ease of construction. In principle, required amount of air can be conveyed through the air conditioning ducts by a number of combinations. However, for a given system, only one set results in the optimum design. Hence, it is essential to identify the relevant design parameters and then optimize the design.

As the duct system for the proper distribution of cold air, costs nearly 20% to 30% of the total cost of the equipment required. Thus, it is necessary to design the air duct system in such a way that the capital cost of ducts and the cost of running the fans is lower.

## 2. LITERATURE REVIEW

R. Whalley et al. considered HVAC modeling methods for large scale, spatially dispersed in this paper, they discussed existing techniques and proposals for the application of novel analysis.

Tengfang T. Xu et al. Did field study on the performance of five thermal distributed systems in four large commercial buildings. They studied about the air leakage from duct, and concluded that the air leakage in large commercial systems varied significantly from a system to system. The energy loss due to a leak can be minimized by using duct sealing and duct insulation.

BarisOzerdem et al. studied the energy loss related to the air leakage by using power law model. The measurements were made on different types of duct having different diameter. After measurements, they concluded that the most of the air leakage was from the joint and this air leakage was reduced by about 50% by using sealing gaskets.

Michal Krajčík et al. studied experimentally air distribution, ventilation effectiveness and thermal environments, in a simulated room in a low-energy building heated and ventilated by warm air. The measurements were performed at different outdoor conditions, internal heat gain, air change rates. Their study showed that the warm air heating and floor heating system did not affect the significant risk of thermal discomfort.

G. S. Sharma et al. designed a duct for an air conditioning system in an office building and analyzed the importance of duct design which creates an impact of system performance. Improper duct designs led to problems such as frictional loss, uneven cooling in the building, increased installation cost, increased noise level and power consumption. The above problems highlighted the need for an optimum duct design and effective layout of the duct. The authors used hand calculation and software tool both for designing the duct. They found that the circular duct has a less pressure drop than the rectangular duct.

William J. Fisk et al. did field studies in large commercial buildings and they investigated the effective leakage areas ELAs, air-leakage rates, and conduction heat gains of duct systems. Air leakage rates were measured by using different method and their result were compared. They found that the air leakage rate varied from 0% to 30%. Also, heat gains between the cooling coils and the supply registers caused supply air temperatures to increase, on average, by 0.68°C to 28°C.

Liping Pang et al. determined the ratio of fresh air to recirculation air. The conditioned temperature of different types of inlets were designed carefully to achieve the high air quality, thermal comfort and energy saving. Furthermore, some experiments were conducted and their performances were compared with the other systems. Their results indicated that, the improved pattern maintain high air quality, because it transported more fresh air directly to the breathing zone and circulated it around the upper body of passengers.

K. Srinivasan et al. Gained an experience for evaluation of air leakages in components of air conditioning systems by designing and testing of orifice plate-based flow measuring systems. The coefficients of discharge were evaluated and compared with the Stoltz equation which value were higher, the deviations being larger in the low Reynolds number. It was observed that a second-degree polynomial was inadequate to relate the pressure drop and flow rate.

Huan-RueiShiu et al. designed an exhaust duct system using the dynamic programming method in semiconductor factory which considered system pressure equilibrium the least life-cycle cost to originate the duct size and fan capacity. Their results showed that the outcomes value satisfied the requirements on the range of duct diameter. Also, the differences between the design and simulation (actual operation) resulted under DPM were found to be much lower than those of other methods.

Wanyu R. Chanet al. analyzed the air leakage measurements of 134,000 single-family detached homes in the US, using normalized leakage. They performed regression analyses to examine the relationship between NL and various house characteristics. Their results indicated that the regression model predicted 90% of US houses had NL between 0.22 and 1.95, with a median of 0.67.

DongliangZhanget al. studied the energy saving possibility of digital variable multiple air conditioning system and compared to the other the air systems with constant air volume and primary air fan coil system. Their results revealed that

the energy saving of DVM air conditioning system was significant under only part load condition and this system was significant when building area was less than 20,000 m<sup>2</sup>. A.

IsakKotcioglu et al. found out an optimum value of design parameters in a rectangular duct by using Taguchi method. Their analysis was performed with an optimization process to reach the minimum pressure drop and maximum heat transfer. After some experiments they gave a suitable designed parameter which satisfied the condition i.e. less friction drop, maximum heat transfer.

### 3. AIM & OBJECTIVES

1. Air should be conveyed as directly as possible to save space, power and material.
2. Sudden changes in directions should be avoided. When not possible to avoid sudden changes, turning vanes should be used to reduce pressure loss.
3. Diverging sections should be gradual. Angle of divergence  $\leq 20^\circ$ .
4. Aspect ratio should be as close to 1.0 as possible. Normally, it should not exceed 4.
5. Air velocities should be within permissible limits to reduce noise and Vibration.
6. Duct material should be as smooth as possible to reduce frictional losses

### 4. METHODOLOGY

This project gives the fundamental principles of duct or air distribution system design for a multi-story Office. There are mainly three types of duct sizing method namely (i) equal friction method, (ii) modified friction method (static regain method) and (iii) velocity reduction method. Now a days, the use of manual duct calculator is normal and computer aided duct design is becoming more popular. Also understanding the friction chart is very important to use this manual duct calculator, because these are the foundations of the other methods. This will provide the necessary knowledge to the duct design error and overcome to the errors.

For designing a proper duct system, it is necessary to estimate cooling load which is used to select the zone and air flow rate that the duct system distributes. Once the air flow rate is determined, the duct system component can be placed. This includes the supply and returns diffusers and decides to air handling unit (AHU) or fan coil unit (FCU) is good for that space.

### 5. DESIGN OF SYSTEM

The project broadly consists of three main phases. Firstly, designing the air conditioning system and calculating the specifications of the AHU (Air Handling Unit), thus enabling us to determine the size of the ducts. The office pant layout for duct work has shown in below:

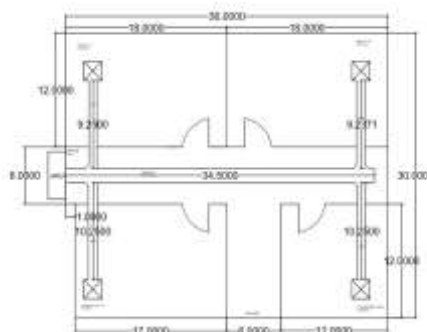

**Table -1:** design values by Ductsizer software

LOCATIONS	AIR FLOW (cfm)	FLUID VELOCIT Y (ft/min)	Equivalent Diameter (inch)	DUCT SIZING (inch)		Reynolds number (Re)	Friction factor	Velocity pressure (in.WC)	Head Loss (in.WC/ 100 ft)
Office - 1	300	605	9.2	11	7	50.086	0.0236	0.0228	0.068
Office - 2	300	660	9.2	12	6	52.0233	0.0236	0.027	0.084

Conference room	400	690	10.3	12	8	61.81	0.0228	0.0298	0.079
Lunch break room	230	590	8.4	10	6	43.58	0.0245	0.0223	0.078
Main duct	1230	880	15.7	18	12	123	0.0199	0.0486	0.073

Table -2: design value as per theoretical calculations

locations	Air Flow (CFM)	Equivalent Diameter (inch)	DUCT (inch)	SIZING
Office - 1	300	9.2	11	7
Office - 2	300	9.2	12	6
Conference Room	400	10.3	12	8
Lunch Break Room	230	8.4	10	6
Total for main duct	1230	15.7	18	12

### 6. DETAILS OF IMPLEMENTATIONS

In this implementations chapter, the all of the project where previously invented parts or researches can be implements. In this project duct design can be done by different method and different shapes then it can be analyze by the analysis software and result can be compare with another shapes, which shapes gives a better results we can observed and implements into the duct design. The duct design are implements many people or authors but they are not to an analyze with comparisons so I am done this with Ansys CFD and FLUENT analysis where pressure drop, velocity contours, etc are find out and compare with another design. I am done comparisons with circular duct and there respectively rectangular duct. They all cases we can be analyze them and find the results.

### 7. RESULTS

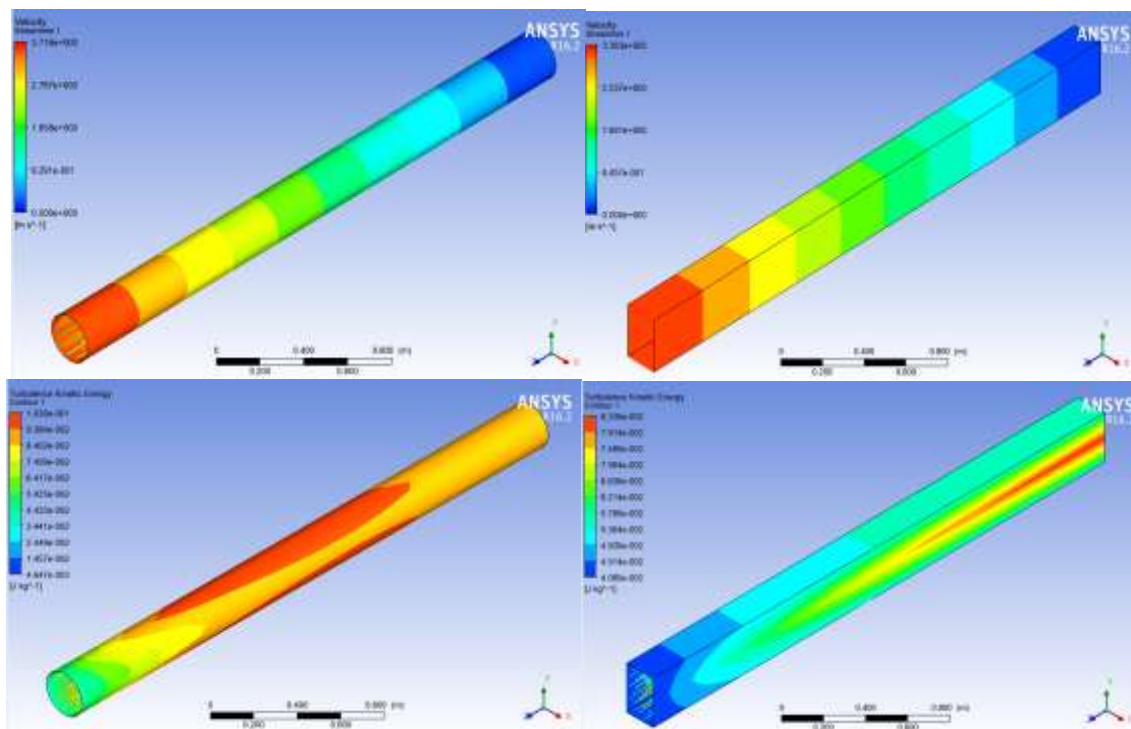



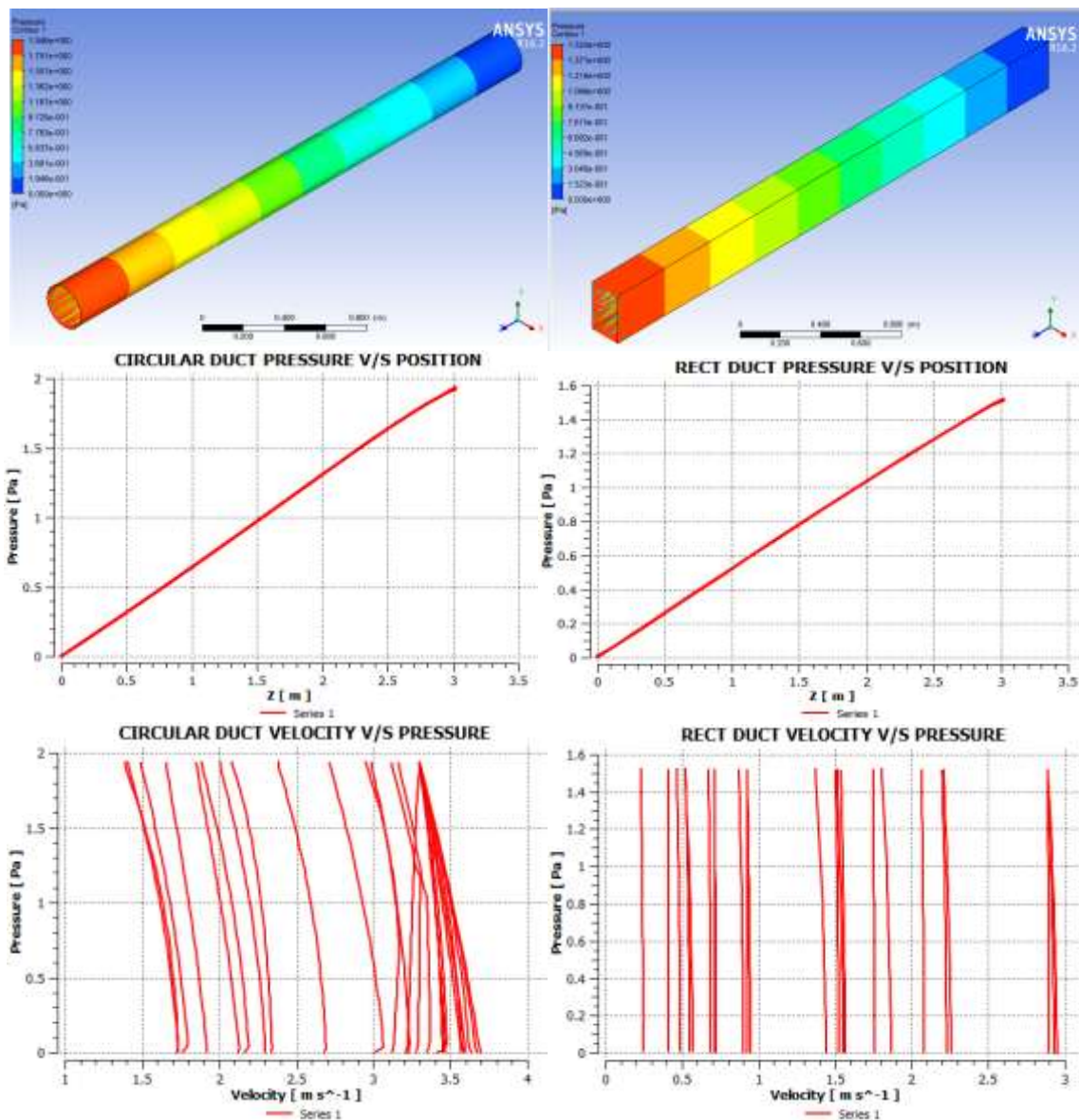

Chart -1: For a circular duct and rect duct various results

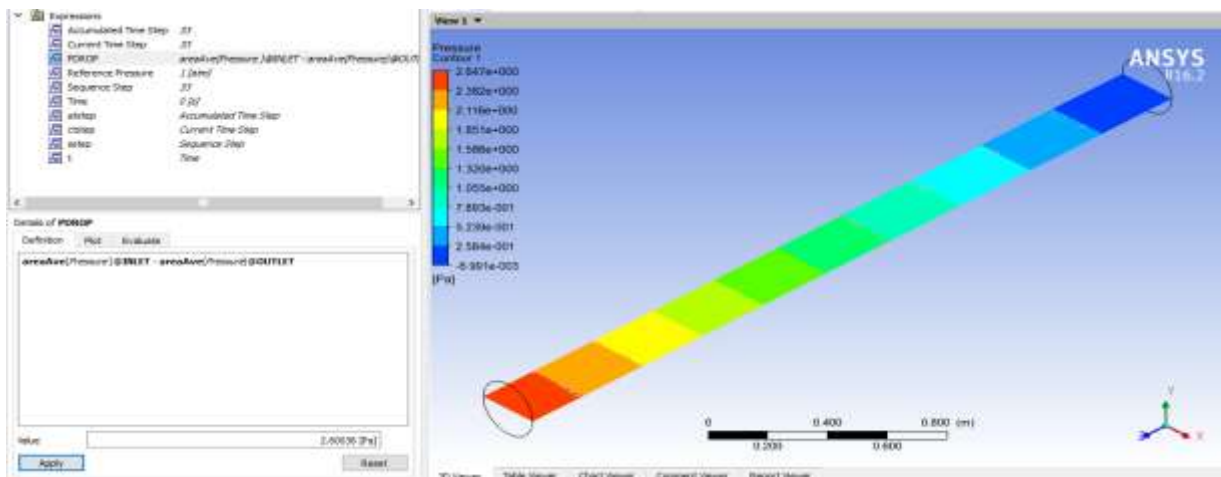
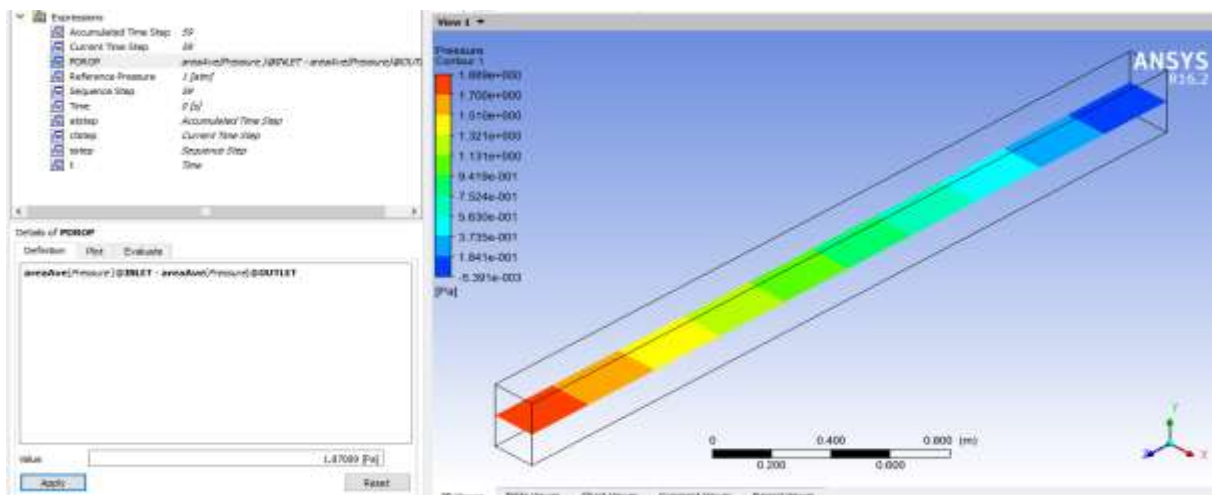

Chart -2: pressure drop calculations of circular duct



**Chart -3:** pressure drop calculations of rect duct

## 8. CONCLUSION

In a rectangular duct more turbulence as compare to circular duct and the pressure drop of a circular duct can be more as compare to rectangular duct. Theoretically it is known that the turbulence for a typical system comprising of straight ducts is lower for a circular duct system than for a rectangular. Therefore one can very well conclude that by selecting a circular duct system for the above application; great saving can be obtained in terms of operating costs (power consumed by the fan is directly proportional to the pressure drop). But the above methodology can also be extended further to explore the relative costs and benefits in selecting a particular section by using the pressure loss data obtained above to calculate the running costs and compare them to the installation costs.

## REFERENCES

- 1) American Society of Heating, Refrigerating and Air conditioning Engineers, "ASHRAE Handbook and Product Diary", Atlanta
- 2) Edward G. Pita, "Air Conditioning Principles and Systems", Cengage Publications, New York, 2002.
- 3) Lindab Ventilation, "Ductwork turns full circle", Scandia consult, Sweden
- 4) D. L. David, "Recovery Effects in Binary Aluminum Alloys", Ph.D. Thesis, Harvard University, 1998.
- 5) M.T. Ke. Design of test method and detailed ratings of variable air volume fan-coil units. Building and Environment 37 (2002) 447-453.
- 6) F. R. Carrie, A. Bossaer, J. V. Andersson, P. Wouters, M. W. Liddament. Duct leakage in European buildings: status and perspectives. Energy and Buildings 32 (2000) 235
- 7) K.W. Cheong. Airflow measurements for balancing of air distribution system tracer gas technique as an alternative. Building and Environment 36 (2011) 955
- 8) S. Marinetti, G. Cavazzini, L. Fedele, F. D. Zan. Air velocity distribution analysis in the air duct of a display cabinet by PIV technique. International journal of refrigeration 35 (2012) 2321-2331.
- 9) M. J. Alonso, T. Andresen, F. Frydenlund. Improvement of air flow distribution in a freezing tunnel using airpak. Procedia food science 1 (2011) 1231-1238.
- 10) C. Li, J. Zhao. Experimental study of indoor air temperature distribution of gravity air conditioning for cooling. Energy Procedia 17 (2012) 961-967.
- 11) R. S. Khurmi, J. K. Gupta. A textbook of Refrigeration and Air Conditioning.
- 12) S. K. Wang, 2001. Handbook of Air Conditioning and Refrigeration.